

TECHNICAL MANUAL

**DIRECT SUPPORT AND
GENERAL SUPPORT
MAINTENANCE**

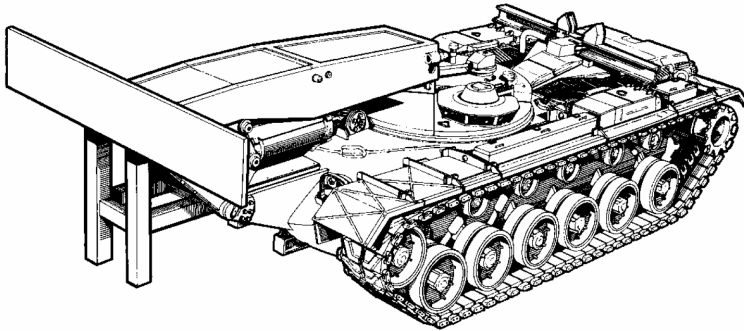

**M48A5 TANK CHASSIS,
TRANSPORTING:
FOR BRIDGE,
ARMORED-VEHICLE-LAUNCHED;
SCISSORING TYPE, CLASS 60
(5420-01-076-6096)**

TABLE OF CONTENTS	i
HOW TO USE THIS MANUAL	iii
INTRODUCTION	1-1
HULL MAINTENANCE INSTRUCTIONS	2-1
ENGINE MAINTENANCE	3-1
FUEL MAINTENANCE	4-1
ELECTRICAL SYSTEM MAINTENANCE	5-1
TRANSMISSION MAINTENANCE	6-1
FINAL DRIVE MAINTENANCE	7-1
BRAKE SYSTEM MAINTENANCE	8-1
SUSPENSION SYSTEM MAINTENANCE	9-1
STEERING SYSTEM MAINTENANCE	10-1
SMOKE GRENADE LAUNCHER MAINTENANCE	10.1-1
FIRE FIGHTING SYSTEM MAINTENANCE	11-1
PRE-EMBARKATION	12-1
REFERENCES	A-1
EXPENDABLE SUPPLIES AND MATERIALS LIST	B-1
ELECTRICAL SCHEMATICS	C-1
ILLUSTRATED LIST OF MANUFACTURED ITEMS	D-1
ALPHABETICAL INDEX	Index-1
MAINTENANCE INFORMATION INDEX	MI-1

DISTRIBUTION STATEMENT A. Approved for public release; distribution is unlimited.

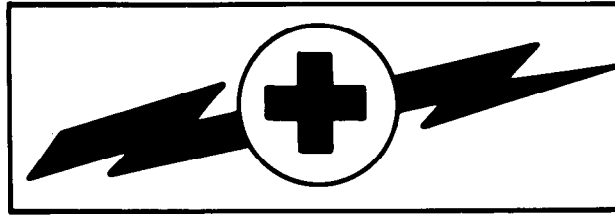

WARNING

CARBON MONOXIDE POISONING CAN BE DEADLY

Carbon monoxide is a colorless, odorless, deadly poisonous gas, which when breathed deprives the body of oxygen and causes suffocation. Exposure to air contaminated with carbon monoxide produces symptoms of headache, dizziness, loss of muscular control, apparent drowsiness, and/or coma. Permanent brain damage or death can result from severe exposure. Carbon monoxide occurs in the exhaust fumes of fuel-burning heaters and internal-combustion engines and becomes dangerously concentrated under conditions of inadequate ventilation. The following precautions must be observed to make sure of the safety of personnel whenever the personnel heater, main or auxiliary engine of any vehicle is operated for maintenance purposes or tactical use.

1. **DO NOT** operate heater or engine of vehicle in an enclosed area unless it is **ADEQUATELY VENTILATED**.
2. **DO NOT** idle engine for long periods without maintaining **ADEQUATE VENTILATION** in personnel compartments.
3. **DO NOT** drive any vehicle with inspection plates, cover plates, or engine compartment doors removed unless necessary for maintenance purposes.
4. **BE ALERT** at all times during vehicle operation for exhaust odors and exposure symptoms. If either are present, **IMMEDIATELY VENTILATE** personnel compartments. If symptoms persist, remove affected personnel from vehicle and treat as follows: expose to fresh air; keep warm; **DO NOT PERMIT PHYSICAL EXERCISE**.

THE BEST DEFENSE AGAINST CARBON MONOXIDE POISONING IS ADEQUATE VENTILATION.

For artificial respiration, refer to FM 21-11.

TA108206

Change 1

a/(a.1 blank)



WARNING

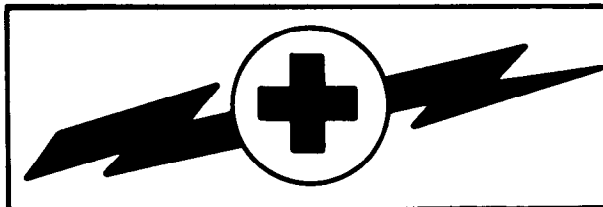

**WARNING
HIGH VOLTAGE**

Used in the operation of this equipment

DEATH ON CONTACT

May result if personnel fail to observe safety precautions.

Never work on electronic equipment unless there is another person nearby who is familiar with the operation and hazards of the equipment and who has an understanding in giving first aid. When a technician is aided by operators, he must warn them about dangerous areas.

Whenever possible, the master battery switch and battery ground straps should be either turned off or disconnected before beginning work on the equipment.

Whenever the nature of the operation permits, keep one hand away from the equipment to reduce the hazard of current flowing through vital organs of the body.

For artificial respiration, refer to FM 21-11.

**WARNING
HAZARDOUS NOISE**

1. Hearing protection (helmet) required.
2. Double hearing protection (helmet and ear plugs) required on road marches at speeds over 15 mph.

TA108207

WARNING

The following summary list is adapted from the warnings within the manual. However, all warnings should be observed as noted in the text.

Compressed air used for cleaning purposes will not exceed 30 psi. Use only with effective chip guarding and personnel protective equipment (goggles/shield, gloves, etc.).

When draining or filling fuel tanks, post notice that smoking is not allowed in or near vehicle.

Cleaning agent specified is flammable. Use only in well ventilated areas. Keep away from flames, sparks, or heat. Do not smoke while using. Prevent contact with eyes, mouth, and/or skin. Wear rubber gloves when performing cleaning procedures.

Keep hands and feet away from carrier when installing drive gear.

Make sure powerplant is level and will not move.

When removing fuel tank, post notice that smoking is not allowed in or near work area.

Make sure to disconnect three battery ground straps.

CHANGE

NO. 4

TM 5-5420-226-34

C4

HEADQUARTERS

DEPARTMENT OF THE ARMY

WASHINGTON, D.C., 29 December 2006

**DIRECT SUPPORT AND GENERAL SUPPORT
MAINTENANCE**

**M 48A5 TANK CHASSIS TRANSPORTING
FOR
BRIDGE, ARMORED-VEHICLE-LAUNCHED,
SCISSORING TYPE, CLASS 60
(NSN 5420-01-076-6096)**

File this change sheet in front of the publication for reference purposes.

Remove Pages

Insert Pages

None	A thru C/(D blank)
i thru iii/(iv blank)	i thru iv
4-1 and 4-2	4-1 and 4-2
4-9 thru 4-38	None
4-39 and 4-40	(4-39 blank)/4-40
4-41 thru 4-64	4-41 and 4-64
5-1 and 5-2	5-1 and 5-2
5-3 and 5-4	5-3/(5-4 blank)
5-5 thru 5-74	None
5-75 and 5-76	5-75 and 5-76
I-1 thru I-6	I-1 thru I-6
2028 Sample and blank	None
2028 and Envelope	2028 and back
2028 and Envelope	2028 and back
2028 and Envelope	2028 and back
Front Cover (inside blank)	Front Cover and PIN

DISTRIBUTION STATEMENT A: Approved for public release; distribution is unlimited

File this change sheet in front of the publication for reference purposes.

TM 5-5420-226-34
C4

By Order of the Secretary of the Army:

PETER J. SCHOOMAKER
General, United States Army
Chief of Staff

Official:



JOYCE E. MORROW
Administrative Assistant to the
Secretary of the Army
0615906

Distribution: To be distributed in accordance with the initial distribution number (IDN) 371222 requirements for TM 5-5420-226-34.

CHANGE

NO. 3

HEADQUARTERS
DEPARTMENT OF THE ARMY
Washington D.C., 7 October 1992

TECHNICAL MANUAL

DIRECT SUPPORT AND GENERAL SUPPORT
MAINTENANCE MANUAL

M48A5 TANK CHASSIS,
TRANSPORTING:
FOR BRIDGE,
ARMORED-VEHICLE-LAUNCHED
SCISSORING TYPE, CLASS 60
(5420-01-076-6096)

TM 5-5420-226-34, 27 February 1981, is changed as follows:

1. Remove old pages and insert new pages as indicated below.
2. New or changed material is indicated by a vertical bar in the margin of the page.

Remove Pages

2-1 and 2-2
2-7 thru 2-10
3-53 and 3-54
3-59 and 3-60
None
3-63 and 3-64
4-53 and 4-54
4-57 and 4-58
6-19 and 6-20
6-31 and 6-32
7-1 thru 7-17/(7-18 blank)
None
8-1 thru 8-4
8-9 thru 8-12
9-1 thru 9-6

Insert Pages

2-1 and 2-2
2-7 thru 2-10
3-53 and 3-54
3-59 and 3-60
3-60.1/(3-60.2 blank)
3-63 and 3-64
4-53 and 4-54
4-57 and 4-58
6-19 and 6-20
6-31 and 6-32
7-1 thru 7-18
7-19 thru 7-30
8-1 thru 8-4
8-9 thru 8-12
9-1 and 9-6

File this change sheet in front of the publication for reference purposes.

Approved for public release; distribution is unlimited.

Remove Pages

9-7 and 9-8
None
9-9 thru 9-14
None
9-15 and 9-16
11-1 and 11-2
A-1 and A-2
B-1 and B-2
D-3/(D-4 blank)
I-1 thru I-6
MI-1 and MI-2

Insert Pages

9-7 and 9-8
9-8.1 and 9-8.2
9-9 thru 9-14
9-14.1/(9-14.2 blank)
9-15 and 9-16
11-1 and 11-2
A-1 and A-2
B-1 and B-2
D-3 and D-4
I-1 thru I-6
MI-1 and MI-2

By Order of the Secretary of the Army:

Official:

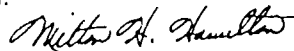

MILTON H. HAMILTON
*Administrative Assistant to the
Secretary of the Army*

02911

GORDON R. SULLIVAN
*General, United States Army
Chief of Staff*

Distribution:

To be distributed in accordance with DA Form 12-37-E, Block No. 1222, Direct Support and General Support maintenance requirements for TM 5-5420-226-34.

CHANGE
NO. 2

HEADQUARTERS
DEPARTMENT OF THE ARMY
Washington, D.C., 11 September 1986

Direct Support and General Support
Maintenance Manual

M48A5 TANK CHASSIS, TRANSPORTING: FOR BRIDGE,
ARMORED-VEHICLE-LAUNCHED SCISSORING TYPE, CLASS 60
(5420-01-076-6096)

TM 5-5420-226-34, 27 February 1981, is changed as follows:

1. Remove old pages and insert new pages as indicated below.
2. New or changed material is indicated by a vertical bar in the margin of the page.

Remove Pages

i and ii
3-57 and 3-58
3-65 thru 3-68
6-21 thru 6-24
C-1/(C-2 blank)
Blank DA Forms 2028-2
None

Insert Pages

i and ii
3-57 and 3-58
3-65 thru 3-68
6-21 thru 6-24
C-1/(C-2 blank)
Blank DA Forms 2028-2
FO-2

File this change sheet in front of the publication for reference purposes.

By Order of the Secretary of the Army:

JOHN A. WICKHAM, JR.
General, United States Army
Chief of Staff

Official:

R.L. DILWORTH
Brigadier General, United States Army
The Adjutant General

Distribution:

To be distributed in accordance with DA Form 12-37, Direct and General Support maintenance requirements for Tank, Bridge Launched, M48A5 (AVLB).

CHANGE
NO. 1

HEADQUARTERS
DEPARTMENT OF THE ARMY
WASHINGTON, D.C. 2 December 1985

DIRECT SUPPORT AND GENERAL SUPPORT
MAINTENANCE
M48A5 TANK CHASSIS,
TRANSPORTING:
FOR BRIDGE, ARMORED-VEHICLE-LAUNCHED
SCISSORING TYPE, CLASS 60
(5420-01-076-6096)

TM 5-5420-226-34, 27 February 1981, is changed as follows:

1. Remove old pages and insert new pages as indicated below.
2. New or changed material is indicated by a vertical bar in the margin of the page.
3. New illustrations are indicated by a vertical bar adjacent to the illustration identification number.

Remove Pages	Insert Pages
None	a/(a.1 blank)
i and ii	i and ii
1-1 and 1-2	1-1 and 1-2
2-1 and 2-2	2-1 and 2-2
None	10.1-1 thru 10.1-7/(10.1-8 blank)
A-1 and A-2	A-1 and A-2
B-1 and B-2	B-1 and B-2
I-3 and I-4	I-3 and I-4
MI-1 and MI-2	MI-1 and MI-2
DA Forms 2028-2	DA Forms 2028-2
Cover and a	Cover
FO-1 Sheet 1 of 3	FO-1 Sheet 1 of 3
FC-1 Sheet 2 of 3	FO-1 Sheet 2 of 3
FO-1 Sheet 3 of 3	FO-1 Sheet 3 of 3

File this change sheet in front of the publication for reference purposes.

By Order of the Secretary of the Army:

JOHN A. WICKHAM, JR.
General, United States Army
Chief of Staff

Official:

MILDRED E. HEDBERG
Brigadier General, United States Army
The Adjutant General

Distribution:

To be distributed in accordance with DA Form 12-37, Direct Support and General Support for Launching System, M48A5 (AVLB).

LIST OF EFFECTIVE PAGES

INSERT LATEST CHANGED PAGES. DESTROY SUPERSEDED PAGES.

Note: The portion of the text affected by the changes is indicated by a vertical line or an asterisk.

Dates of issue for original and changed pages are:

- Original 027 February 1981
- Change 1.....2 December 1985
- Change 2.....11 September 1986
- Change 3.....07 October 1992
- Change 4.....29 December 2009

TOTAL NUMBER OF PAGES IN THIS PUBLICATION IS 360, CONSISTING OF THE FOLLOWING:

Page No.	*Change No.	Page No.	*Change No.	Page No.	*Change No.
Front Cover	4	3-18	0	3-63	0
Front Cover Back PIN	4	3-19	0	3-64	0
a	1	3-20	0	3-65	0
a.1 BLANK	1	3-21	0	3-66	2
b	0	3-22	0	3-67	0
c	0	3-23	0	3-68	2
A ADDED	4	3-24	0	3-69	0
B ADDED	4	3-25	0	3-70 BLANK	0
C ADDED	4	3-26	0	4-1	4
D ADDED BLANK	4	3-27	0	4-2	0
i	4	3-28	0	4-3	0
ii	1	3-29	0	4-4	0
iii	4	3-30	0	4-5	0
iv ADDED	4	3-31	0	4-6	0
1-1	1	3-32	0	4-7	0
1-2	0	3-33	0	4-8	0
2-1	3	3-34	0	4-9 DELETED	4
2-2	3	3-35	0	4-10 DELETED	4
2-4	0	3-36	0	4-11 DELETED	4
2-5	0	3-37	0	4-12 DELETED	4
2-6	0	3-38	0	4-13 DELETED	4
2-7	3	3-39	0	4-14 DELETED	4
2-8	3	3-40	0	4-15 DELETED	4
2-9	0	3-41	0	4-16 DELETED	4
2-10	3	3-42	0	4-17 DELETED	4
3-1	0	3-43	0	4-18 DELETED	4
3-2	0	3-44	0	4-19 DELETED	4
3-3	0	3-45	0	4-20 DELETED	4
3-4	0	3-46	0	4-21 DELETED	4
3-5	0	3-47	0	4-22 DELETED	4
3-6	0	3-48	0	4-23 DELETED	4
3-7	0	3-49	0	4-24 DELETED	4
3-8	0	3-50	0	4-25 DELETED	4
3-9	0	3-51	0	4-26 DELETED	4
3-10	0	3-52	0	4-27 DELETED	4
3-11	0	3-53	3	4-28 DELETED	4
3-12	0	3-54	0	4-29 DELETED	4
3-13	0	3-55	0	4-30 DELETED	4
3-14	0	3-56	0	4-31 DELETED	4
3-15	0	3-57	2	4-32 DELETED	4
3-16	0	3-58	0	4-33 DELETED	4
3-17	0	3-59	0	4-34 DELETED	4
		3-60	3	4-35 DELETED	4
		3-60.1 ADDED	3	4-36 DELETED	4
		3-60.2 ADDED BLANK	3	4-37 DELETED	4
		3-61	0	4-38 DELETED	4
		3-62	0	4-39 DELETED BLANK	4

*Zero in this column indicates an original page.

Page No.	*Change No.	Page No.	*Change No.	Page No.	*Change No.
4-40	4	5-3	4	5-64 DELETED	4
4-41	0	5-4 DELETED BLANK	4	5-65 DELETED	4
4-42 DELETED	4	5-5 DELETED	4	5-66 DELETED	4
4-43 DELETED	4	5-6 DELETED	4	5-67 DELETED	4
4-44 DELETED	4	5-7 DELETED	4	5-68 DELETED	4
4-45 DELETED	4	5-8 DELETED	4	5-69 DELETED	4
4-46 DELETED	4	5-9 DELETED	4	5-70 DELETED	4
4-47 DELETED	4	5-10 DELETED	4	5-71 DELETED	4
4-48 DELETED	4	5-11 DELETED	4	5-72 DELETED	4
4-49 DELETED	4	5-12 DELETED	4	5-73 DELETED	4
4-50 DELETED	4	5-13 DELETED	4	5-74 DELETED	4
4-51 DELETED	4	5-14 DELETED	4	5-75	4
4-52 DELETED	4	5-15 DELETED	4	5-76	0
4-53 DELETED	4	5-16 DELETED	4	5-77	0
4-54 DELETED	4	5-17 DELETED	4	5-78	0
4-55 DELETED	4	5-18 DELETED	4	5-79	0
4-56 DELETED	4	5-19 DELETED	4	5-80	0
4-57 DELETED	4	5-20 DELETED	4	5-81	0
4-58 DELETED	4	5-21 DELETED	4	5-82	0
4-59 DELETED	4	5-22 DELETED	4	5-83	0
4-60 DELETED	4	5-23 DELETED	4	5-84	0
4-61 DELETED	4	5-24 DELETED	4	5-85	0
4-62 DELETED	4	5-25 DELETED	4	5-86	0
4-63 DELETED	4	5-26 DELETED	4	5-87	0
4-64	4	5-27 DELETED	4	5-88	0
4-65	0	5-28 DELETED	4	5-89	0
4-66	0	5-29 DELETED	4	5-90	0
4-67	0	5-30 DELETED	4	5-91	0
4-68	0	5-31 DELETED	4	5-92	0
4-69	0	5-32 DELETED	4	5-93	0
4-70	0	5-33 DELETED	4	5-94	0
4-71	0	5-34 DELETED	4	5-95	0
4-72	0	5-35 DELETED	4	5-96	0
4-73	0	5-36 DELETED	4	6-1	0
4-74	0	5-37 DELETED	4	6-2	0
4-75	0	5-38 DELETED	4	6-3	0
4-76	0	5-39 DELETED	4	6-4	0
4-77	0	5-40 DELETED	4	6-5	0
4-78	0	5-41 DELETED	4	6-6	0
4-79	0	5-42 DELETED	4	6-7	0
4-80	0	5-43 DELETED	4	6-8	0
4-81	0	5-44 DELETED	4	6-9	0
4-82	0	5-45 DELETED	4	6-10	0
4-83	0	5-46 DELETED	4	6-11	0
4-84	0	5-47 DELETED	4	6-12	0
4-85	0	5-48 DELETED	4	6-13	0
4-86	0	5-49 DELETED	4	6-14	0
4-87	0	5-50 DELETED	4	6-15	0
4-88	0	5-51 DELETED	4	6-16	0
4-89	0	5-52 DELETED	4	6-17	0
4-90	0	5-53 DELETED	4	6-18	0
4-91	0	5-54 DELETED	4	6-19	3
4-92	0	5-55 DELETED	4	6-20	0
4-93	0	5-56 DELETED	4	6-21	0
4-94	0	5-57 DELETED	4	6-22	2
4-95	0	5-58 DELETED	4	6-23	2
4-96	0	5-59 DELETED	4	6-24	0
4-97	0	5-60 DELETED	4	6-25	0
4-98	0	5-61 DELETED	4	6-26	0
5-1	4	5-62 DELETED	4	6-27	0
5-2	0	5-63 DELETED	4	6-28	0

*Zero in this column indicates an original page.

Page No.	*Change No.	Page No.	*Change No.	Page No.	*Change No.
6-29	0	8-18	0	10.1-7	1
6-30	0	8-19	0	10.1-8 BLANK	1
6-31	3	8-20 BLANK	0	11-1	0
6-32	3	9-1	3	11-2	3
6-33	0	9-2 DELETED	3	12-1	0
6-34	0	9-3 DELETED	3	12-2 BLANK	0
6-35	0	9-4 DELETED	3	A-1	3
6-36	0	9-5 DELETED	3	A-2	3
6-37	0	9-6	3	A-3	0
6-38	0	9-7	3	A-4 BLANK	0
6-39	0	9-8	3	B-1	0
6-40	0	9-8.1 ADDED	3	B-2	3
6-41	0	9-8.2 ADDED	3	C-1	2
6-42 BLANK	0	9-9	3	C-2 BLANK	2
7-1	3	9-10	0	D-1	0
7-2	3	9-11	0	D-2	0
7-3	3	9-12	3	D-3	3
7-4	3	9-13	3	D-4	3
7-5	3	9-14	3	I-1	4
7-6	3	9-14.1 ADDED	3	I-2	4
7-7	3	9-14.2 ADDED BLANK	3	I-3	4
7-8	3	9-15	3	I-4	4
7-9	3	9-16	0	I-5	4
7-10	3	9-17	0	I-6	4
7-11	3	9-18	0	MI-1	3
7-12	3	9-19	0	MI-2	3
7-13	3	9-20	0	FO-1 Sheet 1	1
7-14	3	9-21	0	FO-1 Sheet 2	1
7-15	3	9-22	0	FO-1 Sheet 3	1
7-16	3	9-23	0	FO-2	2
7-17	3	9-24	0	Authentication Front	0
7-18	3	9-25	0	Authentication Back	0
7-19	3	9-26	0	2028 Front	4
7-20	3	9-27	0	2028 Back	4
7-21	3	9-28	0	2028 Front	4
7-22	3	10-1	0	2028 Back	4
7-23	3	10-2	0	2028 Front	4
7-24	3	10-3	0	2028 Back	4
7-25	3	10-4	0	Back cover Inside	0
7-26	3	10-5	0	Back cover BLANK	0
7-27	3	10-6	0		
7-28	3	10-7	0		
7-29	3	10-8	0		
7-30	3	10-9	0		
8-1	0	10-10	0		
8-2	3	10-11	0		
8-3	0	10-12	0		
8-4	3	10-13	0		
8-5	0	10-14	0		
8-6	0	10-15	0		
8-7	0	10-16	0		
8-8	0	10-17	0		
8-9	3	10-18	0		
8-10	3	10-19	0		
8-11	3	10-20 BLANK	0		
8-12	3	10.1-1	1		
8-13	0	10.1-2	1		
8-14	0	10.1-3	1		
8-15	0	10.1-4	1		
8-16	0	10.1-5	1		
8-17	0	10.1-6	1		

*Zero in this column indicates an original page.

TECHNICAL MANUAL

HEADQUARTERS
DEPARTMENT OF THE ARMY
WASHINGTON, D.C., 27 February 1981

**DIRECT SUPPORT AND GENERAL SUPPORT
MAINTENANCE
M 48A5 TANK CHASSIS TRANSPORTING
FOR
BRIDGE, ARMORED-VEHICLE-LAUNCHED,
SCISSORING TYPE, CLASS 60
(NSN 5420-01-076-6096)**

REPORTING OF ERRORS AND RECOMMENDING IMPROVEMENTS

You can help improve this publication. If you find any mistakes or if you know of a way to improve the procedures, please let us know. Submit your DA Form 2028 (Recommended Changes to Publications and Blank Forms) through the Internet, on the Army Electronic Product Support (AEPS) website. The Internet address is <https://aeprs.ria.army.mil>. The DA Form 2028 is located under the Public Applications section in the AEPS Public Home Page. Fill out the form and click on SUBMIT. Using this form on the AEPS will enable us to respond quicker to your comments and better manage the DA Form 2028 program. You may also mail, fax, or e-mail your letter or DA Form 2028 directly to: AMSTA-LC-LPIT/TECHPUBS, TACOM-RI, 1 Rock Island Arsenal, Rock Island, IL 61299-7630. The e-mail address is ROCK-TACOM-TECH-PUBS@conus.army.mil. The fax number is DSN 793-0726 or Commercial (309) 782-0726.

DISTRIBUTION STATEMENT A: Approved for public release; distribution is unlimited.

Table of Contents

		Page
	HOW TO USE THIS MANUAL	iii/(iv blank)
CHAPTER 1	INTRODUCTION	1-1
Section 1	General Information	1-1
II	Equipment Description and Data	1-2
CHAPTER 2	HULL MAINTENANCE INSTRUCTIONS	2-1
Section 1	Repair Parts, Specials Tools, TMDE and Support Equipment	2-1
II	Service Upon Receipt	2-2
III	Preliminary Servicing and Adjustment of Equipment-M48A5 AVLB Hull ..	2-8
CHAPTER 3	ENGINE MAINTENANCE	3-1
CHAPTER 4	FUEL SYSTEM MAINTENANCE	4-1

TABLE OF CONTENTS

	Page
CHAPTER 5	ELECTRICAL SYSTEM MAINTENANCE 5-1
CHAPTER 6	TRANSMISSION MAINTENANCE 6-1
CHAPTER 7	FINAL DRIVE MAINTENANCE 7-1
CHAPTER 8	BRAKE SYSTEM 8-1
CHAPTER 9	SUSPENSION SYSTEM MAINTENANCE 9-1
CHAPTER 10	STEERING SYSTEM MAINTENANCE 10-1
CHAPTER 10.1	SMOKE GRENADE LAUNCHER MAINTENANCE 10.1-1
CHAPTER 11	FIRE FIGHTING SYSTEM MAINTENANCE 11-1
CHAPTER 12	PRE-EMBARKATION INSTRUCTIONS 12-1
APPENDIX A	REFERENCES A-1
APPENDIX B	EXPENDABLE SUPPLIES AND MATERIALS LIST B-1
APPENDIX C	ELECTRICAL SCHEMATICS C-1
APPENDIX D	ILLUSTRATED LIST OF MANUFACTURED ITEMS D-1
ALPHABETICAL INDEX I-1
MAINTENANCE INFORMATION INDEX MI-1

HOW TO USE THIS MANUAL:

- Manual is divided into chapters.
- Chapters are by functional group code and presented in same order as the RPSTL (Repair Parts and Special Tool List).
- All manual references refer to page numbers.
- Steps are numbered and are to be performed in that order.
- Be sure to read all NOTES, WARNINGS, and CAUTIONS.
- Locator views are included wherever necessary. These will help you locate the item which the procedure is referencing.
- Jagged circle (✱) on locator (A) indicates a cutout and item is inside of tank.
- A (~) symbol represents the outside surface (B) of a piece of equipment that cannot be shown in its entirety.
- Callouts are shown by a circle with a letter inside.
- Locator arrows (C) are black and mechanical motion arrows (D) are white.

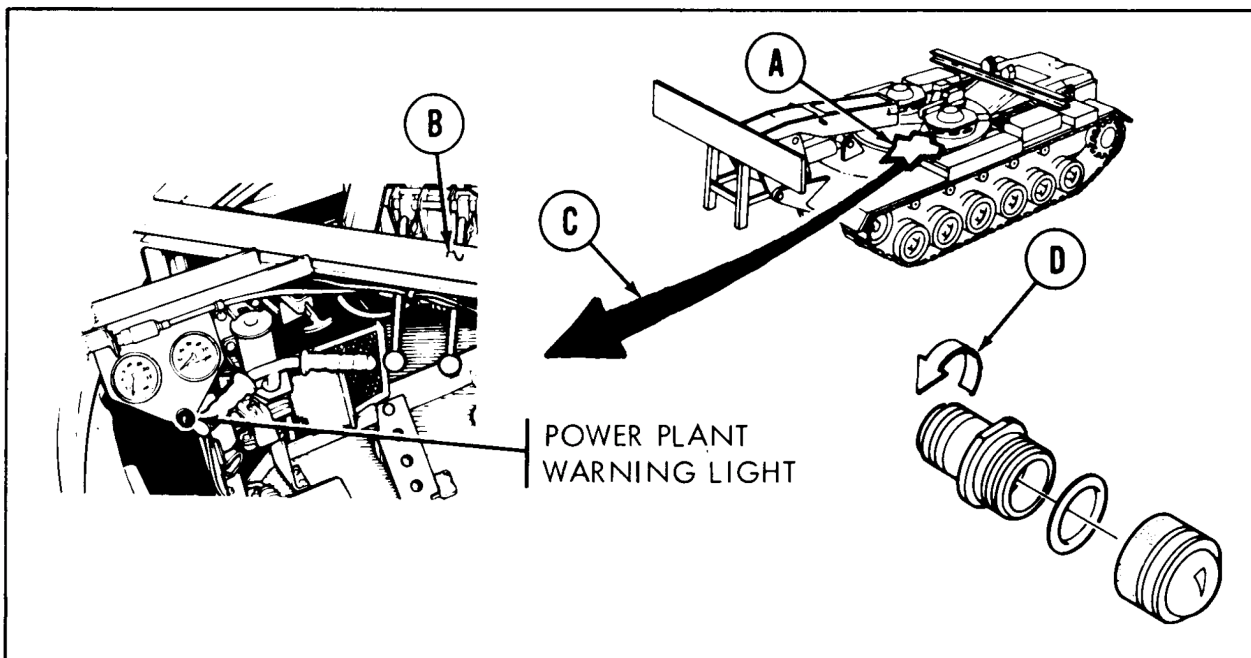

TA108209

HOW TO USE THIS MANUAL - Continued

- An illustrated list of manufactured items includes complete instructions for making items authorized to be manufactured or fabricated and used at direct support and general support maintenance.
- A maintenance information index lists all parts subject to maintenance tasks. It provides the location of all maintenance tasks related to a component in this manual.
- As a general maintenance practice, throw away all removed lockwashers, locknuts, and cotter pins and replace with new lockwashers, locknuts, and cotter pins at installation.
- As a general maintenance practice, throw away all removed lockwashers, locknuts, o-rings, preformed packing, and cotter pins, and replace with new lockwashers, locknuts, o-rings, preformed packing, and cotter pins at installation.

CHAPTER 1

INTRODUCTION

Section L GENERAL INFORMATION

SCOPE

Type of Manual: Direct Support and General Support Maintenance.

Model Number and Equipment Name: M48A5 Tank Chassis, Transporting, for Bridge, Armored-Vehicle-Launched Scissoring Type, Class 60.

Purpose of Equipment: Launch, retrieve, and transport scissoring type bridge.

MAINTENANCE FORMS, RECORDS, AND REPORTS

Department of the Army forms and procedures used for equipment maintenance will be those prescribed by DA PAM 738-750, The Army Maintenance Management System (TAMMS).

REPORTING EQUIPMENT IMPROVEMENT RECOMMENDATIONS (EIR's)

If your M48A5 AVLB needs improvement, let us know. Send us an EIR. You, the user, are the only one who can tell us what you don't like about our equipment. Let us know why you don't like the design. Tell us why a procedure is hard to perform. Put it on an SF 368 (Quality Deficiency Report). Mail it to Commander, U.S. Army Tank-Automotive Command, AMSTA-Q, Warren, Michigan 48397-5000. We'll send you a reply.

CALIBRATION

There are no calibration requirements for the maintenance of any component of the hull.

ENGLISH AND METRIC SYSTEM UNITS

Torque values specified in this manual are expressed in pound feet (lb-ft) or pound inches (lb-in.) followed by the metric equivalent in parentheses. The metric equivalent is expressed in system international units Newton meters (N·m). There is a metric equivalents chart located on the inside rear cover of this manual.

Section II. **EQUIPMENT DESCRIPTION AND DATA**

DESCRIPTION

Refer to TM 5-5420-226-10.

DATA

Refer to TM 5-5420-226-10.

CHAPTER 2
HULL MAINTENANCE INSTRUCTIONS

Section I. **REPAIR PARTS, SPECIAL TOOLS, TMDE, AND SUPPORT EQUIPMENT**

COMMON TOOLS AND EQUIPMENT

For authorized common tools and equipment, refer to the Modified Table of Organization and Equipment (MTOE) applicable to your unit.

SPECIAL TOOLS, TMDE, AND SUPPORT EQUIPMENT

Special tools for direct support and general support maintenance are listed and illustrated in TM 5-5420-226-24P which is the authority for requisitioning replacements.

ENGINE

- | | |
|--|--------------------------------|
| 1. Engine and Transmission Sling
(12257229) | Remove and install powerplant. |
|--|--------------------------------|

TRANSMISSION

- | | |
|---------------------------------------|---|
| 2. Puller Adapter
(7082774) | Used with puller (item 3) to disengage transmission input shaft from engine flywheel. |
| 3. Slide Hammer Puller
(7082201) | Disengage transmission input shaft from engine flywheel. |
| 4. Lifting Sling
(7081593) | Lift transmission. |
| 5. Pinion Turning Wrench
(7081564) | Turn transmission gearing. |

FINAL DRIVE

- | | |
|---------------------------------------|---|
| 6. Box Wrench
(12251988) | Remove and install final drive output shaft nut. |
| 7. Bearing Removal Tool
(12291062) | Remove bearings from final drive output shaft and drive gear. |
| 8. Seal Inserter
(8355822) | Install final drive output shaft seal. |

SUSPENSION

- | | | |
|-----|---|--|
| 9. | Shock Absorber Bearing Replacer
(11654533) | Remove and replace bearings in shock absorber mount. |
| 10. | Bearing Tool Assembly
(12325917) | Remove No. 1 left and right roadwheel arm track adjusting bearing. |
| 11. | Bearing Driver (12290993) | Remove and replace bearing in track adjusting link mount. |

SMOKE GRENADE LAUNCHER

- | | | |
|-----|--------------------------------------|--|
| 12. | Locating Fixture Assembly (12257682) | Position stowage box mounting bracket. |
|-----|--------------------------------------|--|
-

SPARE AND REPAIR PARTS

Spares and repair parts required for direct support and general maintenance of this vehicle are listed and illustrated in TM 5-5420-226-24P which is the authority for ordering replacement parts.

Section II. SERVICE UPON RECEIPT

1. This section contains information on services to be performed upon issue of the vehicle to the using organization. Where practicable, the crew will assist in services described. Some of the services contained herein may not be required, depending upon the degree of preservation provided by the shipper and the planned use of the vehicle.
2. Cut hold-down straps and remove wooden boxes, containers of equipment, and any other vehicle components secured to the exterior or interior of the vehicle.
 - a. Inspect the equipment for damage incurred during shipment. If the equipment has been damaged, report the damage on DD Form 6, Packaging Improvement Report.
 - b. Check the equipment against the packing slip to see if the shipment is complete. Report all discrepancies in accordance with the instructions of DA PAM 738-750.
3. Conduct service upon receipt of the chassis in accordance with the procedures specified on pages 2-3 and 2-4. For services to be performed on launcher and bridge components, refer to TM 5-5420-227-24 and TM 5-5420-203-14.

TABLE I. SERVICE UPON RECEIPT

Step	Item	Action	Remarks
1. Hull	Exterior	Check vehicle hull for damage.	Item 1, Page 2-6
2. Hull	Fender stowage boxes	Inspect for water in two center and two rear fender stowage boxes.	Item 2, Page 2-6 Para. 4a.
3. Hull	Optical glass	Remove wrapping, barrier material, and tape.	- - -
4. Hull (right side)	Personnel heater exhaust assembly	Remove tape.	Item 3, Page 2-6
5. Hull (right and left sides)	Air cleaner (precleaner) centrifugal fan (blower motor) exhaust elbows	Remove tape and protective barrier plugs.	Item 4, Page 2-6 Para. 4b.
6. Hull (top deck)	Turbosupercharger and tubes	Open two top deck hatch door assemblies and remove tape and plugs from two turbosuperchargers and two tubes.	Item 5, Page 2-6 Para. 4c.
7. Hull (top deck)	Air cleaner inlet screens	Open two top deck hatch door assemblies and remove tape from two air cleaner inlet screens at bulkhead.	Item 6, Page 2-6
8. Hull (rear)	Pintle	Remove pintle stowed inside of hull. Install pintle at rear of tank.	Item 7, Page 2-6 Para. 4d.
9. Hull (underside)	Fuel tank drain access openings	Remove two screens at two fuel tank drain access openings.	Item 8, Page 2-6 Para. 4e.
10. Hull (underside)	Brake control access openings	Remove two screens at two brake control access openings.	- - -
11. Hull (underside)	Brake control access covers	Remove two brake control access covers stowed inside hull and install on access openings.	Item 9, Page 2-6 Para. 4f.

TA108212

TABLE I. SERVICE UPON RECEIPT Continued

Step	Item	Action	Remarks	
12.	Hull (under-side)	Front and rear drain valve openings	Remove screens from front and rear drain valve openings.	Item 10, Page 2-6 Para. 4g.
13.	Hull (rear)	Engine exhaust outlet doors	Open engine exhaust outlet doors and remove tape from engine exhaust outlet pipes.	Item 11, Page 2-6
14.	Hull (rear)	Taillights	Remove wrapping and tape from two taillight lenses.	Item 12, Page 2-6
15.	Hull (front)	Fire extinguisher handles	Remove tape from fire extinguisher handles protective shield.	Item 13, Page 2-6 Para. 4h.
16.	Hull (interior)	CO ₂ cylinder plastic blow-off cap or shrink tube	Check for presence of plastic blow-off cap or shrink tube on service valve of CO ₂ cylinder, located near vehicle's batteries.	- - - Para. 4i.
17.	Hull (front)	Headlight mounting receptacles	Remove dust covers from two hull headlight mounting receptacles.	Item 14, Page 2-6 Para. 4j.

TA108213

TABLE I. SERVICE UPON RECEIPT Continued

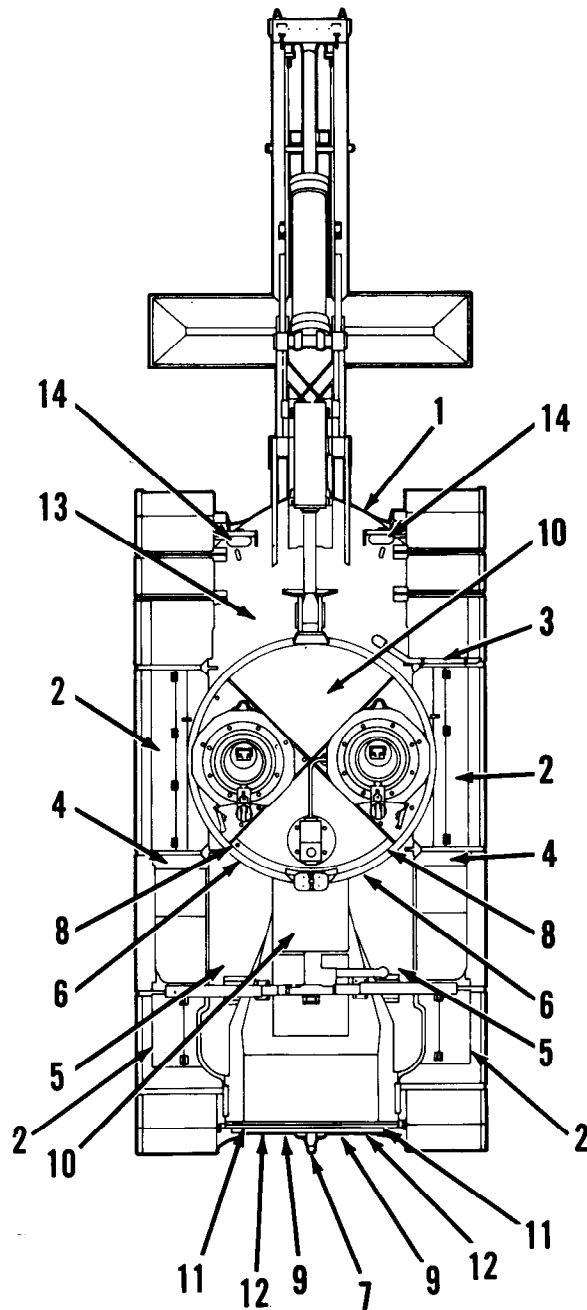

4. Corrective action for items listed in paragraph 3 found deficient will be as follows:

- a. Water in fender storage boxes should be drained by removing drain plugs (two in each box) as required to allow water to drain. After water has drained, reinstall and tighten plugs.
- b. Protective barrier plugs should be reinstalled and tightened after water has drained.
- c. Connect tubes to turbosupercharger. Refer to TM 5-5420-226-20.

TA108214

- d. Refer to TM 5-5420-226-20 for installation of pintle.
- e. Loosen two fuel tank drain plugs and allow water in fuel tanks to drain. After water has drained, tighten drain plugs. Refer to TM 5-5420-226-20.
- f. Refer to TM 5-5420-226-20.
- g. Refer to TM 5-5420-226-20.
- h. Check that lead seals on both handles are intact. If lead seal is broken, service fire extinguisher cylinders. Install new exterior fire extinguisher handle lead seal. Refer to TM 5-5420-226-20.
- i. If missing, service CO₂ cylinder (page 11-2).
- j. Remove headlights from stowage brackets in operator's compartment. Install dust covers on stowage brackets. Install headlights on hull mounting receptacles. Refer to TM 5-5420-226-10.

**SECTION III. PRELIMINARY SERVICING AND ADJUSTMENT OF EQUIPMENT -
M48A5 AVLB HULL****WARNING**

Dry cleaning solvent P-D-680 is toxic and flammable. To avoid injury, wear protective goggles and gloves and use in a well-ventilated area. Avoid contact with skin, eyes, and clothes, and do not breathe vapors. Do not use near open fire or excessive heat. The flash point for Type I dry cleaning solvent is 100°F (38°C) and for Type II is 140°F (60°C). If you become dizzy while using dry cleaning solvent, get fresh air immediately and get medical aid. If contact with eyes is made, wash your eyes with water and get medical aid immediately.

1. If any exterior surfaces of the hull are coated with rust preventive compound, remove the coating with dry cleaning solvent (Item 12, Appendix B).
2. Paint the vehicle in accordance with unit camouflage requirements. After painting, apply exterior non-skid paint, stenciled markings, and insignia. Refer to TM 43-0139.
3. Follow instructions specified on tag DD Form 1397 regarding processing record and stowage of the vehicle and its equipment if the vehicle is not to be placed into immediate service. Tag DD Form 1397 will be found in the operator's compartment, attached to the steering control or transmission shift lever. If the using organization plans to place the vehicle into immediate service:
 - a. Open each wooden box and container. Inventory contents with packing list. Record missing items.
 - b. Check packing list against Basic Issue Items List (BILL) in TM 5-5420-226-10 to make sure all items have been received.
 - c. Open inner packs and remove material.
 - d. Degrease equipment such as tools and hardware as necessary.
 - e. Thoroughly clean articles coated with rust preventive preservatives received from storage with wiping cloth or a brush saturated with dry cleaning solvent (Item 12, Appendix B). After complete removal of preservatives and cleaning compound, lubricate articles as specified in LO 5-5420-226-12.
4. Open the fuel water separator manual drain cock to remove any moisture accumulation in the fuel water separator. Refer to TM 5-5420-226-20.

5. Stow basic issue items as shown.

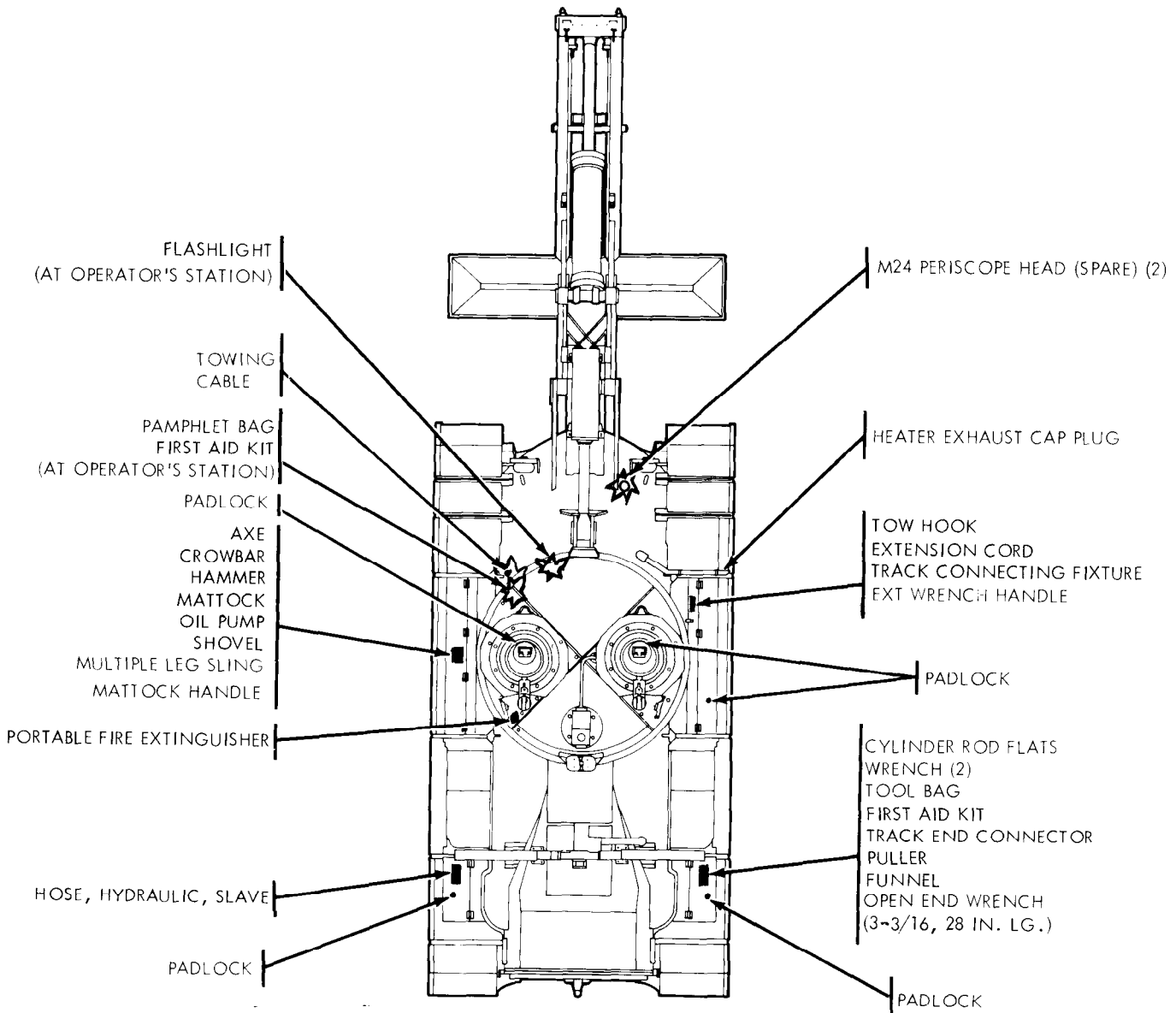

NOTE

Remaining hand tools go in tool bag.

WARNING

Always wear goggles, rubber gloves, and rubber apron when handling batteries. Battery acid is harmful to skin and will ruin clothing.

- 6. Remove six vehicle batteries and electrolyte from wooden equipment boxes. Fill batteries with electrolyte and check specific gravity. Refer to TM 9-6140-200-14. Install batteries in vehicle and connect cables. Refer to TM 5-5420-226-20.

7. Check out the gas particulate filter unit. Refer to TM 5-5420-226-10. After the unit has been checked out, test the unit as follows:
 - a. Slide the spring clip clear of the air inlet openings on the precleaner-particulate filter assembly and switch on the gas particulate switch on the master control panel. Check to see that air issues from filter unit by placing a hand over the filter unit hose.

WARNING

Under arctic winter conditions, there is danger of frostbite due to the inhalation of extremely cold air. Do not connect air duct hose to M25A1 protective mask unless ambient temperature is well above freezing.

- b. Connect the M25A1 protective mask to filter unit hose and make sure a sufficient volume of air reaches each face piece. Have a crew member don and adjust his M25A1 protective mask. Resistance to breathing should not be noticeable.
8. Check all hull bulkheads and engine electrical connectors, jacks, and plugs for routing, installation, and firm seating.
9. Fuel the vehicle. Refer to TM 5-5420-226-10. While fueling, check for leaks at filter connections, fuel tank drain plugs, fuel line quick disconnects, fuel valve, and filters. Correct any leaks found.
10. Check oil level in engine and transmission in accordance with LO 5-5420-226-12. Check processing tag DD Form 1397 for grade of engine oil installed in the vehicle. Change the engine oil only if a different type or grade is required.
11. Service engine air cleaner filters. Refer to TM 5-5420-226-20.
12. Check operation of all controls. Refer to TM 5-5420-226-10.

13. Making sure hand brake is set, start engine. Refer to TM 5-5420-226-10. Check immediately for fuel and oil leaks. Shut down engine and correct leaks if any are found.

NOTE

The engine may start hard, smoke excessively, and run erratically. However, operation should generally improve after about 5 minutes of running time. Failure to obtain full engine power will require performing troubleshooting to isolate and correct the problem.

14. Perform the semiannual Preventive Maintenance Checks and Services (PMCS) listed in TM 5-5420-226-20, including a complete suspension lubrication in accordance with LO 5-5420-226-12.
15. Equipment faults found during preliminary servicing or during the break-in period will be corrected by the using organization or by the supporting maintenance unit as appropriate, depending upon the nature of the fault.
16. Serious equipment faults which appear to involve unsatisfactory design or material will be reported using the Quality Deficiency Report, SF368, as prescribed in DA PAM 738-750, The Army Maintenance Management System (TAMMS).

CHAPTER 3

ENGINE MAINTENANCE

INDEX

Procedure	Page
Power Takeoff Replacement	3-2
Power Takeoff Repair	3-10
Engine Replacement	3-18
Accessory Drive Removal from Replacement Engine	3-19
Power Takeoff Removal from Unserviceable Engine	3-25
Power Takeoff Installation on Replacement Engine	3-35
Accessory Drive Installation on Unserviceable Engine	3-46
Replacement Engine Installation	3-53

POWER TAKEOFF REPLACEMENT (Sheet 1 of 8)

PROCEDURE INDEX

PROCEDURE	PAGE
Removal	3-2
Installation	3-5

TOOLS: Ratchet with 1/2 in. drive
9/16 in. socket with 1/2 in. drive
9/16 in. open end wrench
1/2 in. open end wrench
7/8 in. open end wrench
8 in. pipe wrench

SUPPLIES: Gasket (8725277)
Gasket (7415354)
Clean rags

REFERENCE: TM 5-5420-226-20

PRELIMINARY PROCEDURES:

Disconnect power takeoff
(TM 5-5420-226-20)

Remove upper engine access
cover (TM 5-5420-226-20)

Remove lower engine access
cover (TM 5-5420-226-20)

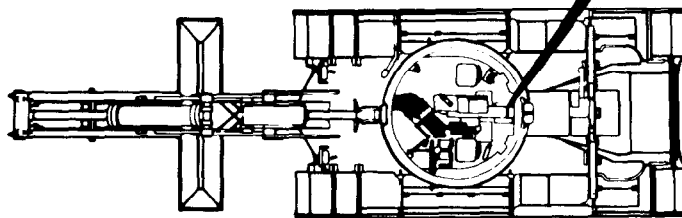
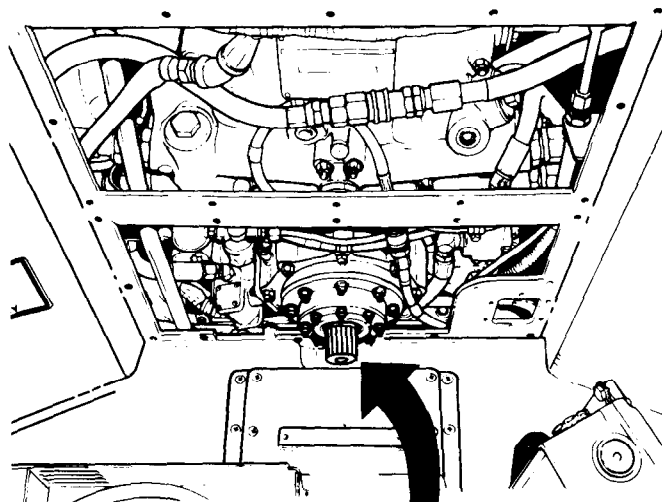

Go on to Sheet 2

TA108216

POWER TAKEOFF REPLACEMENT (Sheet 2 of 8)**REMOVAL:**

1. Using 7/8 inch open end wrench, disconnect hose assembly (A) from fuel pump (B).
2. Using 7/8 inch open end wrench, disconnect hose assembly (C) from fuel pump (B).
3. Using 9/16 inch open end wrench, disconnect hose assembly (D) from external oil supply inlet port of power takeoff (E).
4. Using 9/16 inch socket and ratchet, remove nut and washer (F) securing clamp (G) that attaches hose assembly (D) to power takeoff (E).
5. Using 9/16 inch socket and ratchet, remove seven remaining nuts and washers (F) that secure power takeoff (E) to engine.
6. Grasp power takeoff (E) with both hands.
7. Very carefully withdraw power takeoff from engine, rocking gently as required to prevent binding.
8. Place power takeoff on bench or other suitable work surface.

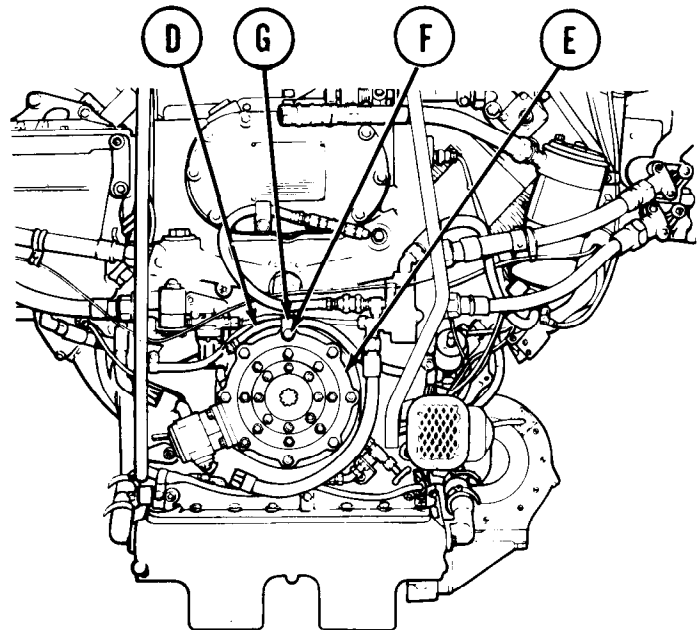
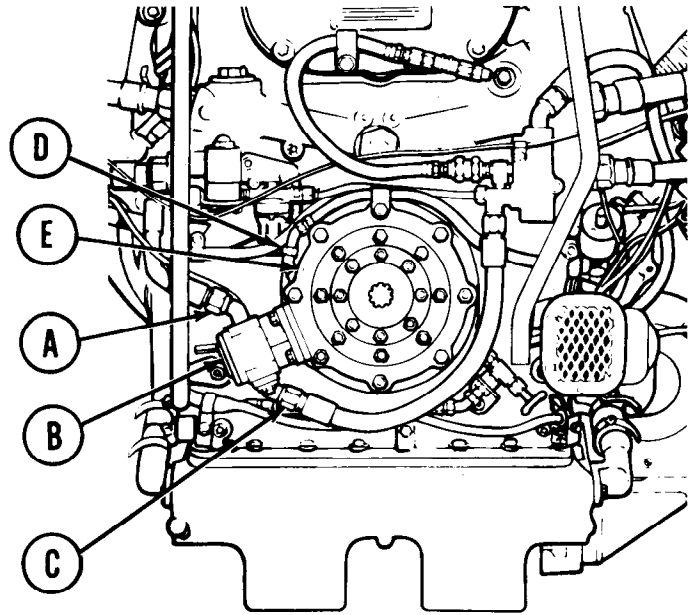

Go on to Sheet 3

TA108217

POWER TAKEOFF REPLACEMENT (Sheet 3 of 8)

9. Wrap rags around two 45-degree elbows (H) on fuel pump (J) to protect threads.
10. Using 8 inch pipe wrench, carefully remove two 45-degree elbows (H) from fuel pump (J).
11. Using 1/2 inch wrench, remove four nuts (K) and four washers (L) that secure pump (J) to studs (M) on power takeoff (E).
12. Carefully remove pump (J) and gasket (N) from power takeoff.
13. Wrap rag around 45-degree elbow (P) to protect threads.
14. Using pipe wrench, carefully remove elbow (P) from oil supply inlet port of power takeoff (E).

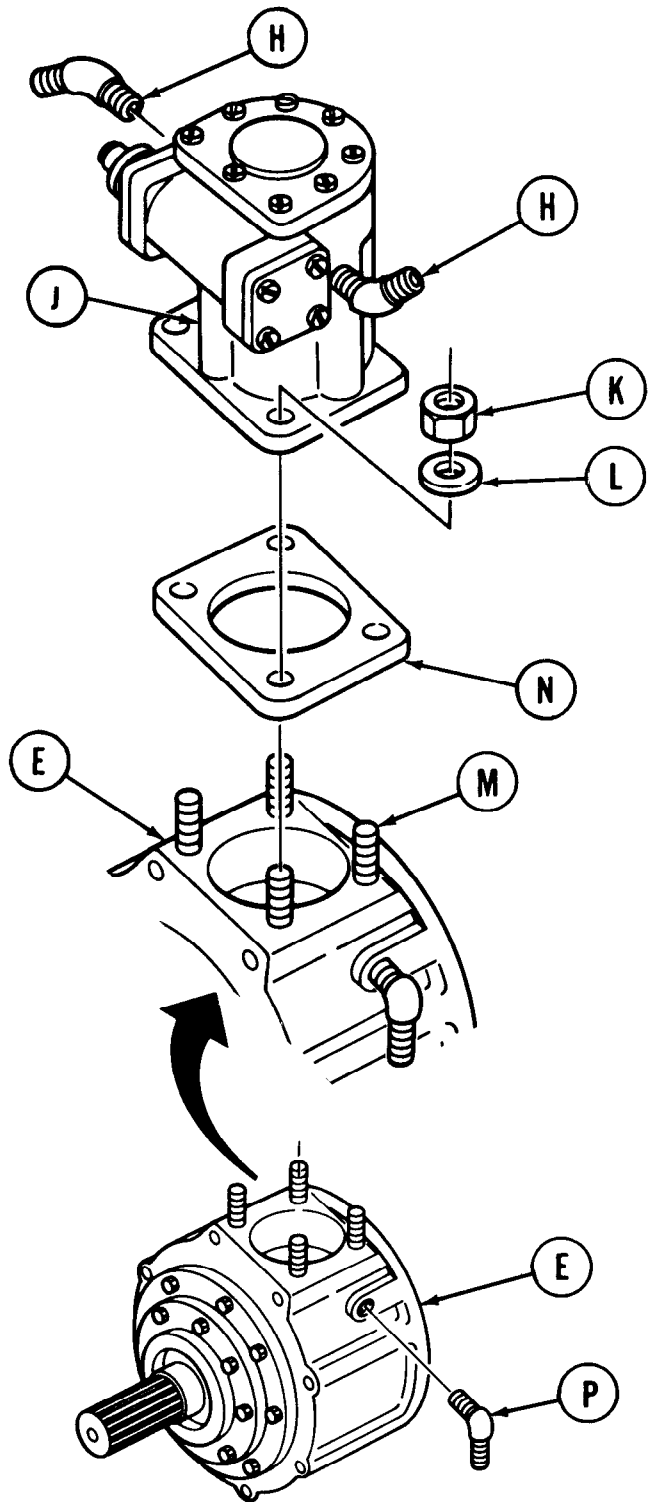

Go on to Sheet 4

TA108218

POWER TAKEOFF REPLACEMENT (Sheet 4 of 8)

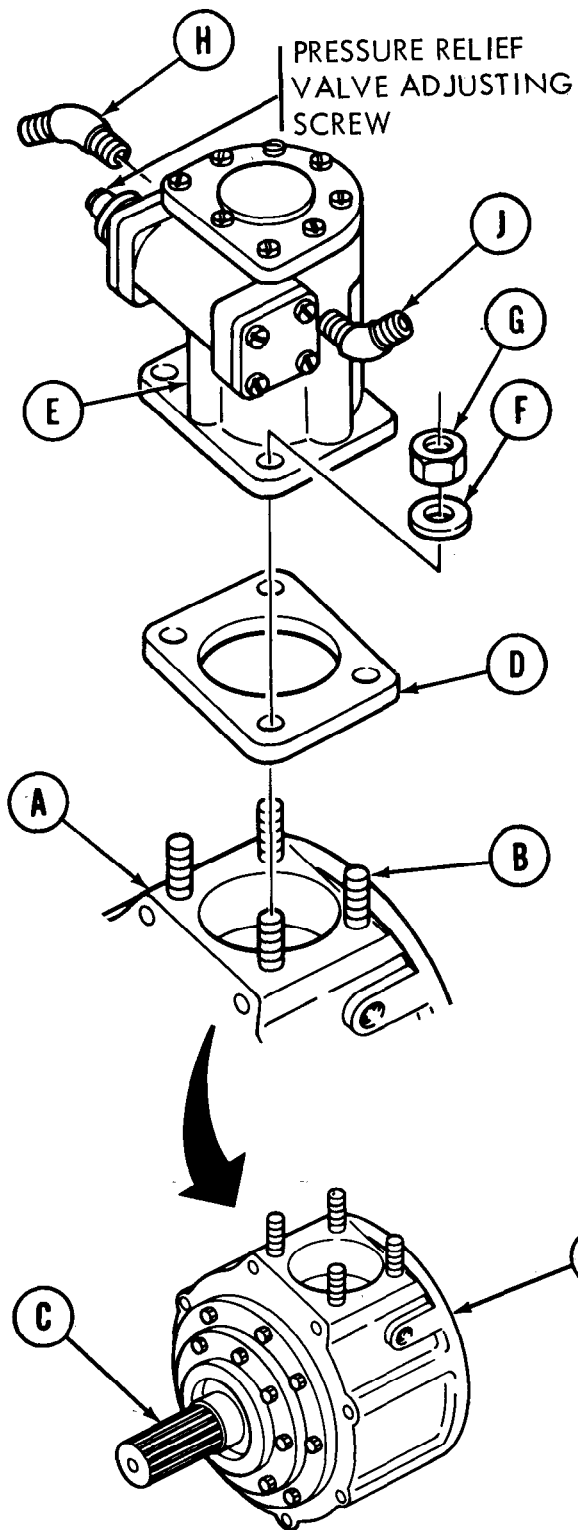

INSTALLATION:

1. Place power takeoff (A) on bench with fuel pump mounting studs (B) facing upward and splined output shaft (C) pointing toward you.
2. Place gasket (D) in position over studs (B).
3. Place fuel pump (E) in position on studs (B). Pump must be positioned so that pump pressure relief valve adjusting screw is on your left as you face it.
4. Using 1/2 inch open end wrench, secure pump (E) to mounting studs (B) with four washers (F) and four nuts (G).
5. Carefully thread two 45-degree elbows (H) and (J) into inlet and outlet ports of pump (E) until elbows are hand tight.
6. Wrap elbows (H) and (J) with clean rags to protect threads.
7. Using 8 inch pipe wrench, carefully tighten elbows (H) and (J) so that they are aligned with long axis of pump (E). Elbow (H) must point downward and elbow (J) must point upward.

Go on to Sheet 5

TA108219

POWER TAKEOFF REPLACEMENT (Sheet 5 of 8)

8. Carefully thread 45-degree elbow (K) into oil supply inlet port of power takeoff (A) until elbow is finger tight.

9. Wrap elbow (K) with clean rag to protect threads.

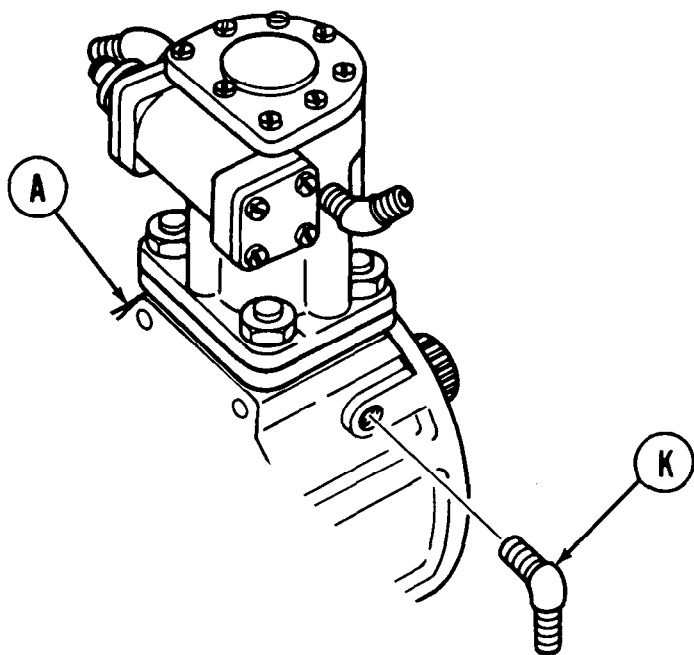

10. Using 8 inch pipe wrench, carefully tighten elbow (K) so that elbow (K) is alined with power takeoff and pointing downward.

Go on to Sheet 6

TA108220

POWER TAKEOFF REPLACEMENT (Sheet 6 of 8)

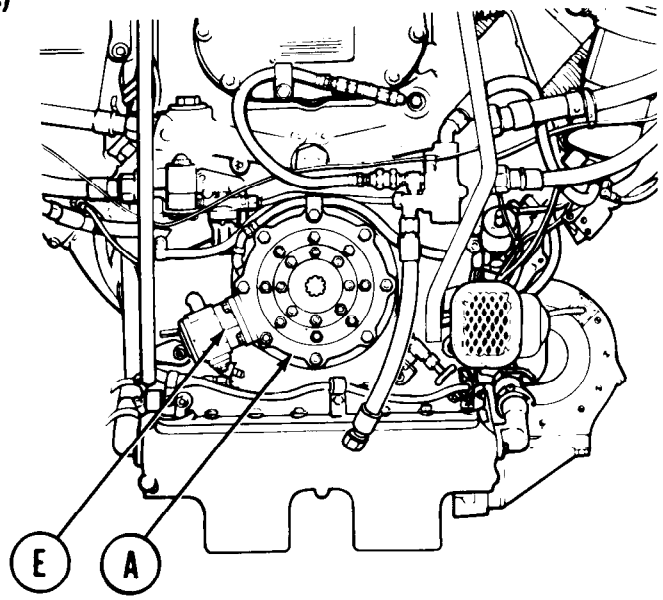
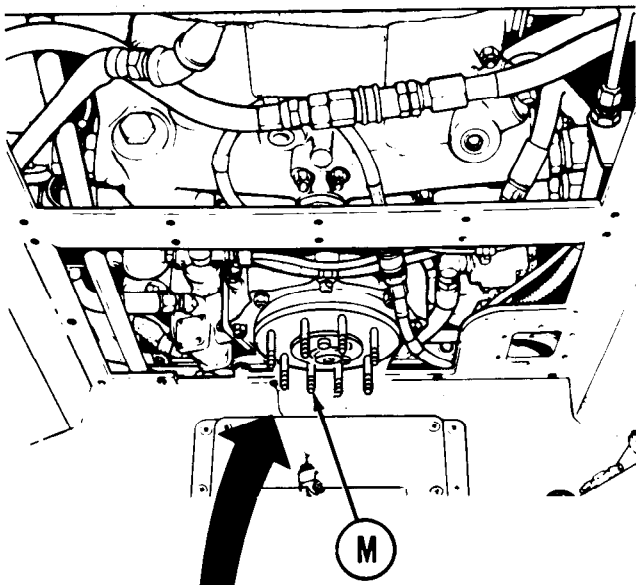

11. Place gasket (L) in position over mounting studs (M) on engine housing.
12. Place power takeoff (A) in position on engine mounting studs (M). Power takeoff must be positioned so that fuel pump (E) is at approximately eight o'clock position.
13. Carefully guide power takeoff short splined input shaft (N) into hole in splined adapter (P).

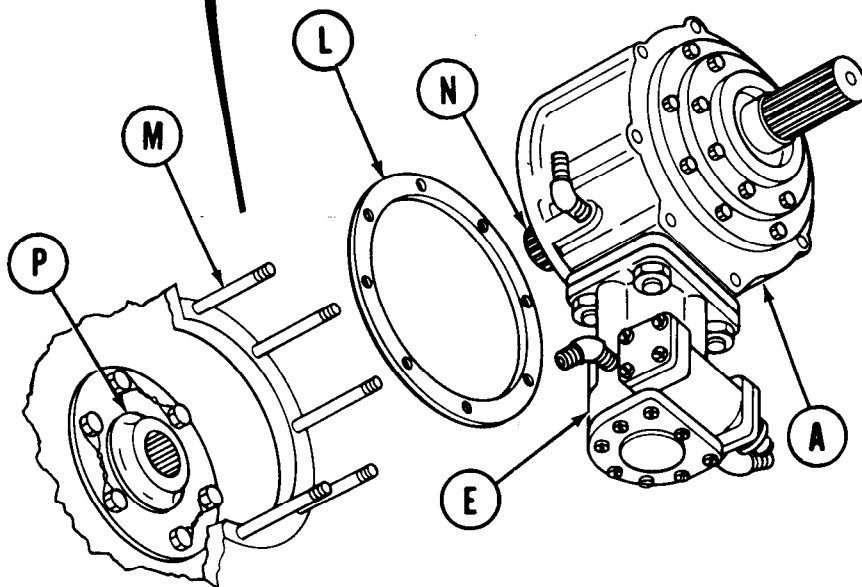

Go on to Sheet 7

TA108221

POWER TAKEOFF REPLACEMENT (Sheet 7 of 8)

14. Place clamp (Q) around hose assembly (R).
15. Using 9/16 inch socket and ratchet, secure hose assembly (R) and clamp (Q) to power takeoff (A) with washer (S) and nut (T).
16. Using 9/16 inch socket and ratchet, secure power takeoff (A) to engine mounting studs with seven remaining washers (S) and nuts (T).

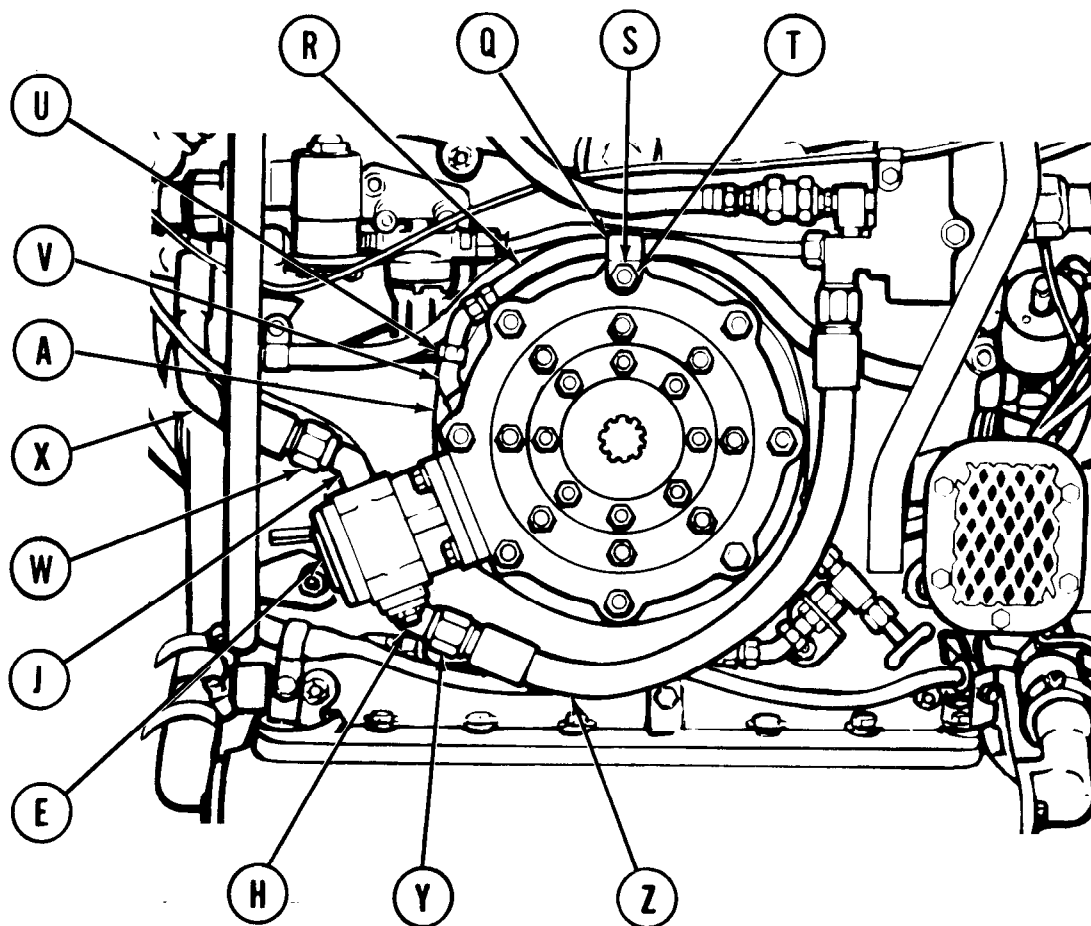

17. Using 9/16 inch open end wrench, install connector nut (U) of hose assembly (R) onto elbow (V) at oil inlet port of power takeoff (A).
18. Using 7/8 inch open end wrench, install connector nut (W) of hose assembly (X) onto elbow (J) at outlet port of fuel pump (E).
19. Using 7/8 inch open end wrench, install connector nut (Y) of hose assembly (Z) onto elbow (H) at inlet port of fuel pump (E).

Go on to Sheet 8

TA108222

POWER TAKEOFF REPLACEMENT (Sheet 8 of 8)

20. Install upper engine access cover (TM 5-5420-226-20).
21. Install lower engine access cover (TM 5-5420-226-20).
22. Connect power takeoff (TM 5-5420-226-20).

End of Task

POWER TAKEOFF REPAIR (Sheet 1 of 8)

PROCEDURE INDEX

PROCEDURE	PAGE
Disassembly	3-10
Cleaning and Inspection	3-14
Assembly	3-14

TOOLS: 7/16 in. socket with 1/2 in. drive
 1/2 in. socket with 1/2 in. drive
 Ratchet with 1/2 in. drive
 1/2 in. combination box and open end wrench
 7/16 in. combination box and open end wrench
 Flat-tip screwdriver
 Internal retaining ring pliers

External retaining ring pliers
 Brass punch
 Hammer
 Putty knife
 Arbor press
 Stud remover/installer

SUPPLIES: Clean rags
 Gasket (10935494)
 Preformed packing (MS29561-135)
 Seal (49417)
 Wood block - 2 in. x 4 in. x 12 in. long (2 required)
 Studs (as required) (7415354)

Engine lubricating oil (Item 17, Appendix B)
 1/4-NC x 1 capscrew (jackscrew) (2 required)
 Dry cleaning solvent (Item 12, Appendix B)
 Sealer (Item 6, Appendix B)
 Self-locking nut (8 required) (MS21045-5)

PRELIMINARY PROCEDURE: Remove power takeoff assembly (page 3-2)

NOTE

Removal of studs (disassembly steps 3 and 11) and installation of studs (assembly steps 7, 17, and 19) may be omitted if studs are not damaged.

POWER TAKEOFF REPAIR (Sheet 2 of 8)**DISASSEMBLY:**

1. Using flat-tip screwdriver, carefully pry fuel pump adapter (A) from power takeoff housing (B).
2. Remove preformed packing (C) from pump adapter (A). Throw packing away.
3. Using stud remover/installer, remove four studs (D) from power takeoff housing (B).
4. Using 7/16 inch socket and ratchet, remove eight self-locking nuts (E), washers (F), and flange (G) from studs (H).

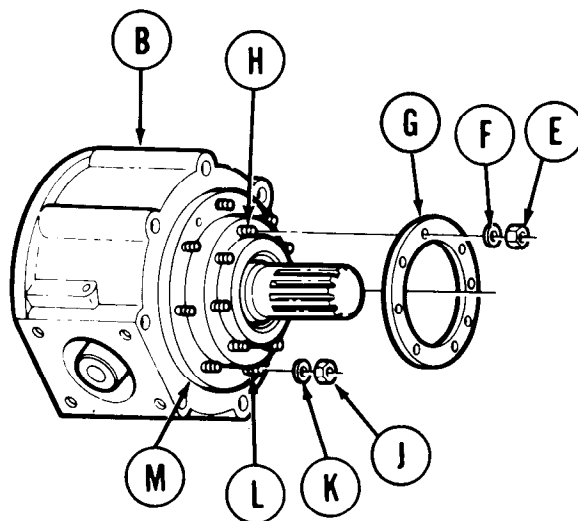
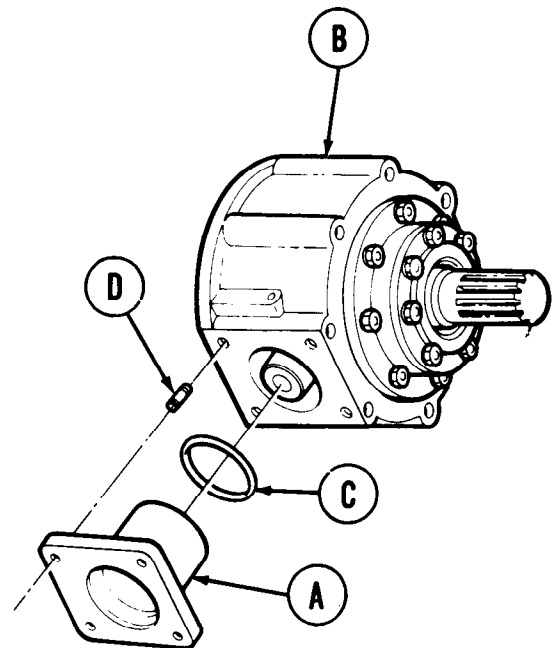

5. Using 1/2 inch socket and ratchet, remove eight self-locking nuts (J) and washers (K) from studs (L).
6. Install two 1/4-NC x 1 inch jackscrews into two threaded holes in cover assembly (M).
7. Using 7/16 inch socket, tighten jackscrews alternately until cover assembly (M) comes away from power takeoff housing (B).
8. Remove cover assembly (M) from power takeoff housing (B).

Go on to Sheet 3

TA108225

POWER TAKEOFF REPAIR (Sheet 3 of 8)

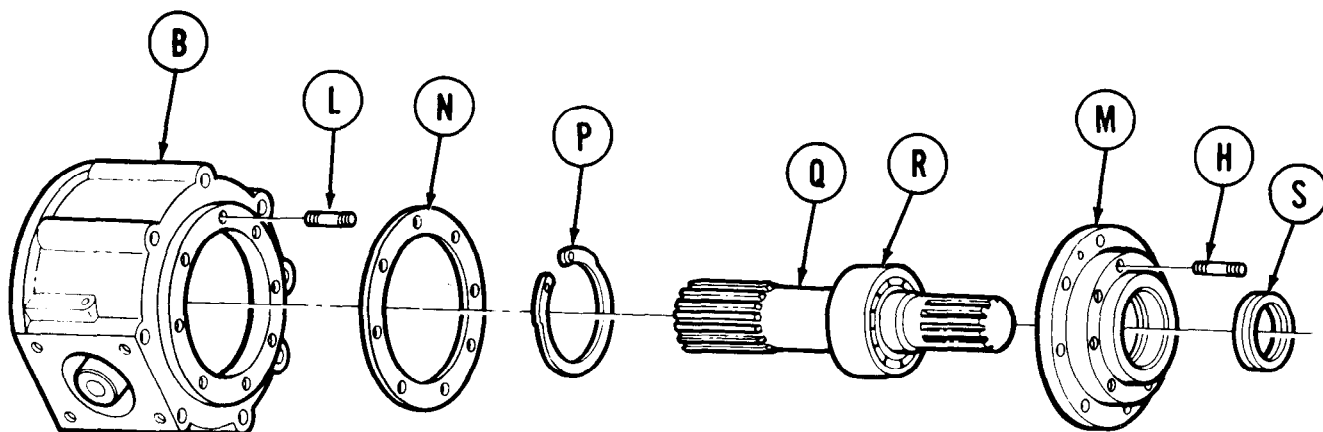

9. Remove two jackscrews used in steps 6 and 7.
10. Remove gasket (N) from cover assembly (M). Throw gasket away.
11. Using stud remover/installer, remove eight studs (L) from power takeoff housing (B) and eight studs (H) from cover assembly (M).
12. Using internal retaining ring pliers, remove retaining ring (P) from cover assembly (M).
13. Using an arbor press, support cover assembly (M) with gasket surface down and press shaft (Q) and bearing (R) from cover (M).
14. Position cover (M) with gasket surface up on two pieces of wood allowing clearance to drive seal (S) from cover.
15. Using a brass punch and hammer, remove seal (S) from cover (M) by alternately driving seal from side to side. Throw seal (S) away.

Go on to Sheet 4

TA108226

POWER TAKEOFF REPAIR (Sheet 4 of 8)

16. Using external retaining ring pliers, remove retaining ring (T) from shaft (Q).
17. Using an arbor press, support bearing (R) with large spline end of shaft (Q) facing down.
18. Press shaft (Q) from bearing (R).
19. Position power takeoff housing (B) on workbench with surface of fuel pump adapter facing down toward bench.

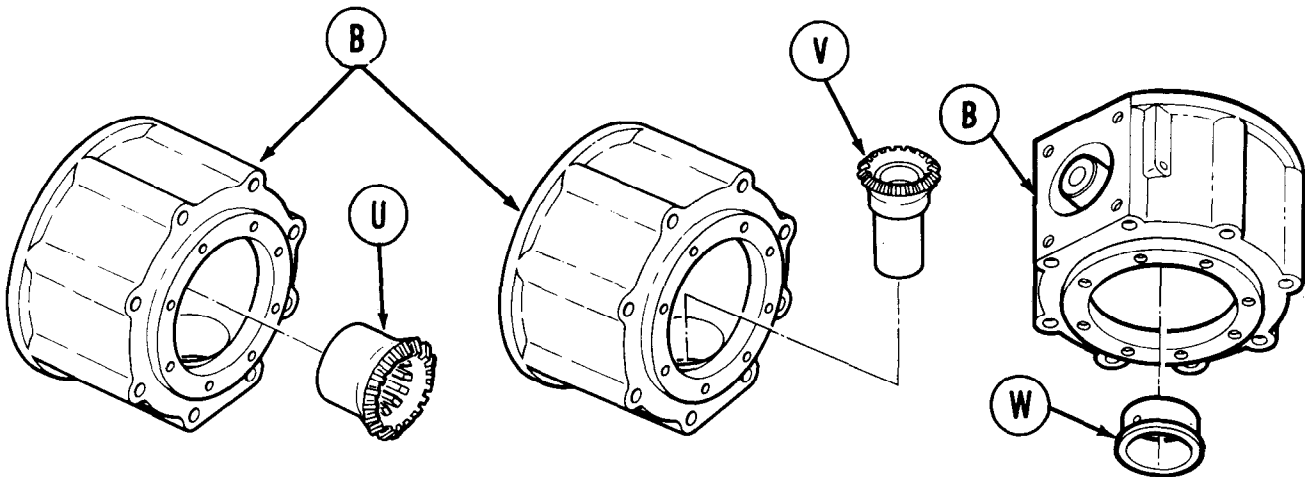
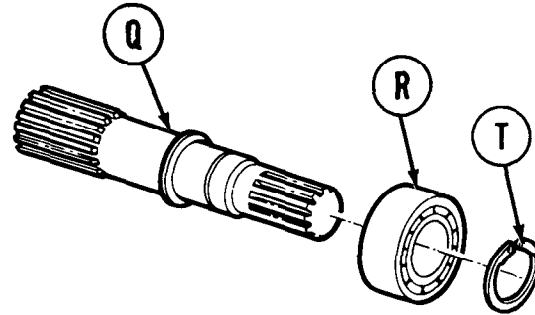

20. Remove pinion ring gearshaft (U) from power takeoff housing (B).
21. Remove pinion drive gearshaft (V) from power takeoff housing (B).
22. Position power takeoff housing (B) on a workbench with cover surface facing down.
23. Using a brass punch and hammer, drive housing bushing (W) from power takeoff housing (B).

Go on to Sheet 5

TA108227

POWER TAKEOFF REPAIR (Sheet 5 of 8)

CLEANING AND INSPECTION:

1. Using dry cleaning solvent, clean all parts of power takeoff assembly.
2. Using putty knife, scrape all remaining gasket material from gasket surfaces.
3. Check all parts and surfaces for cracks, damage, and/or wear.

ASSEMBLY:

1. Position power takeoff housing (A) on bench with cover surface facing up.

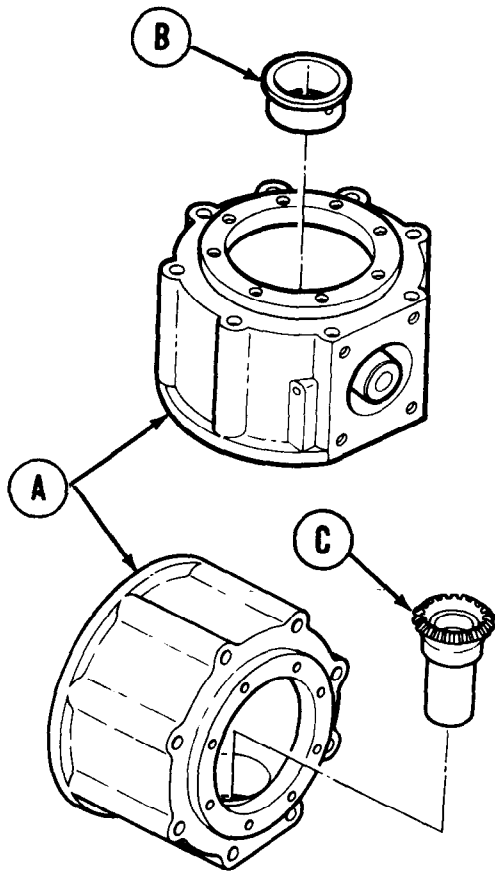

2. Position power takeoff housing bushing (B) in housing (A) with bushing lubricating hole alined with supply hole in housing (A).
3. Using a brass punch and hammer, install bushing (B) by driving it in until flange of bushing (B) bottoms in housing (A).
4. Position power takeoff housing (A) on bench with fuel pump adapter surface resting on bench.
5. Install pinion drive gearshaft (C) into power takeoff housing (A).

Go on to Sheet 6

TA108228

POWER TAKEOFF REPAIR (Sheet 6 of 8)

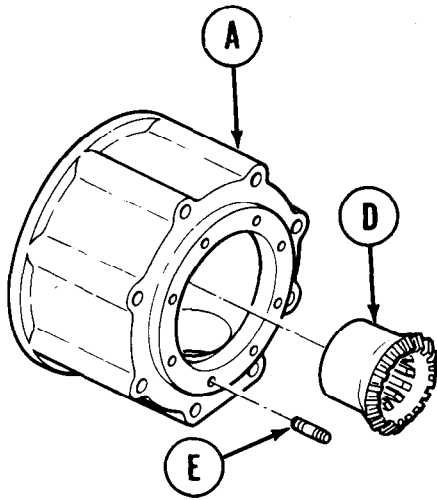

6. Install pinion ring gearshaft (D) into power takeoff housing (A).
7. Using stud remover/installer, install eight studs (E) into power takeoff housing (A).

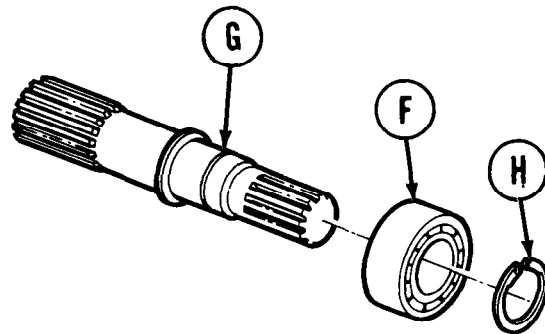

8. Using an arbor press, support bearing (F) and press shaft (G) into bearing (F).
9. Using external retaining ring pliers, install retaining ring (H) onto shaft (G).

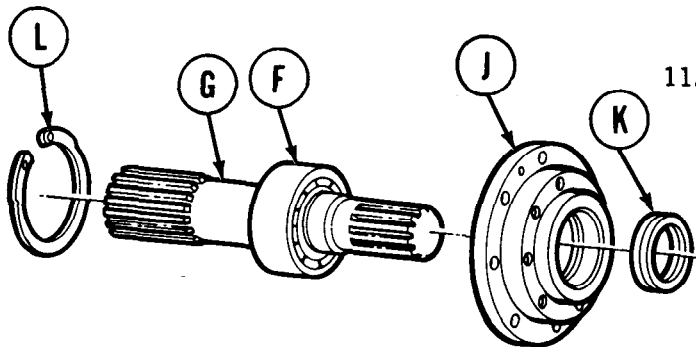

10. Position cover (J) with gasket surface down.
11. Using a brass punch and hammer, install seal (K) into cover (J) by alternately driving sides of seal (K).

12. Using an arbor press, support front cover (J) with gasket surface facing up and press bearing (F) with shaft (G) into cover (J).
13. Using internal retaining ring pliers, install ring (L) into front cover (J).

Go on to Sheet 7

TA108229

POWER TAKEOFF REPAIR (Sheet 7 of 8)

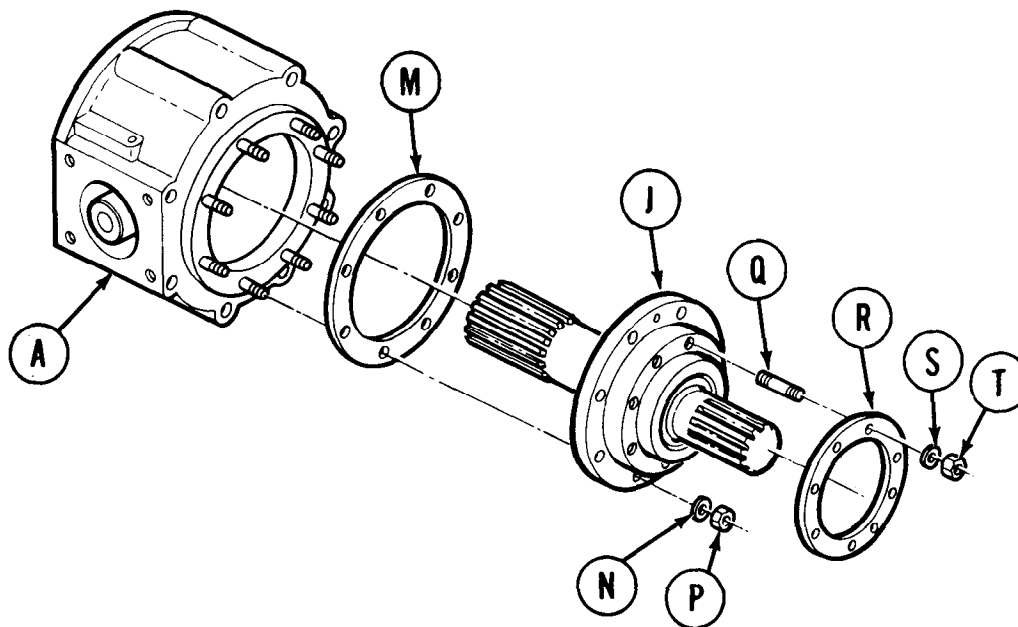

14. Using sealer, install gasket (M) onto power takeoff housing (A).
15. Install cover assembly (J) into power takeoff housing (A) and secure with eight washers (N) and self-locking nuts (P).
16. Using 1/2 inch socket, tighten eight nuts (P).
17. Using stud remover/installer, install eight studs (Q) into cover (J).
18. Install flange (R) and secure with eight washers (S) and self-locking nuts (T).

Go on to Sheet 8

TA108230

POWER TAKEOFF REPAIR (Sheet 8 of 8)

19. Using stud remover/installer, install four studs (U) into power takeoff housing (A).
20. Install new preformed packing (V) on fuel pump adapter (W). Lubricate with engine lube oil.
21. Install fuel pump adapter (W) into power takeoff housing (A).

End of Task

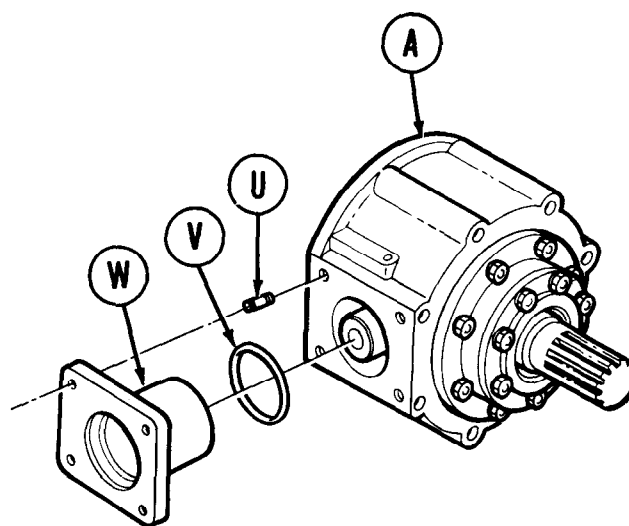

TA108231

ENGINE REPLACEMENT

Engine replacement requires the transfer of components between the unserviceable engine and the replacement engine. The following must be performed to replace the engine.

PRELIMINARY PROCEDURES:

WARNING

Make sure powerplant is level and will not move.

Using powerplant sling (Item 1, Chapter 2, Section I) and suitable hoist (engine weighs approximately 5,000 pounds), remove replacement engine from container and place on two 10 x 10 x 12 inch wooden blocks. Position blocks under each end of engine oil pan. Remove powerplant sling from engine.

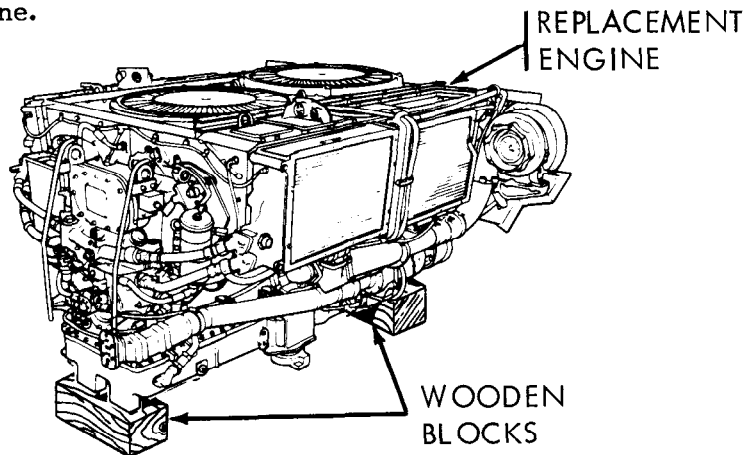

- Remove powerplant (TM 5-5420-226-20)
- Remove steering linkage and brackets (TM 5-5420-226-20)
- Remove shifting linkage and brackets (TM 5-5420-226-20)
- Remove engine shroud and supports (TM 5-5420-226-20)
- Remove engine mounts (TM 5-5420-226-20)

PROCEDURE INDEX

PROCEDURE	PAGE
Accessory Drive Removal from Replacement Engine	3-18
Power Takeoff Removal from Unserviceable Engine	3-25
Power Takeoff Installation on Replacement Engine	3-35
Accessory Drive Installation on Unserviceable Engine	3-46
Replacement Engine Installation	3-61

ENGINE REPLACEMENT**Accessory Drive Removal From Replacement Engine (Sheet 1 of 6)****NOTE**

Replacement engines are received without the power takeoff unit installed. The PTO parts on the unserviceable engine must be exchanged with the accessory drive parts of the replacement engine.

TOOLS: Ratchet with 1/2 in. drive
7/16 in. socket with 1/2 in. drive
9/16 in. socket with 1/2 in. drive
5/8 in. socket with 1/2 in. drive
13/16 in. socket with 1/2 in. drive
9/16 in. combination box and open end wrench
5/8 in. combination box and open end wrench
13/16 in. combination box and open end wrench
7/8 in. combination box and open end wrench
Putty knife
Stud remover/installer
Wire cutting pliers
8 in. socket wrench extension with 1/2 in. drive

SUPPLIES: Clean rags

REFERENCE: TM 5-5420-226-20

NOTE

Retain all parts removed from replacement engine for installation on unserviceable engine.

Go on to Sheet 2

ENGINE REPLACEMENT

Accessory Drive Removal From Replacement Engine (Sheet 2 of 6)

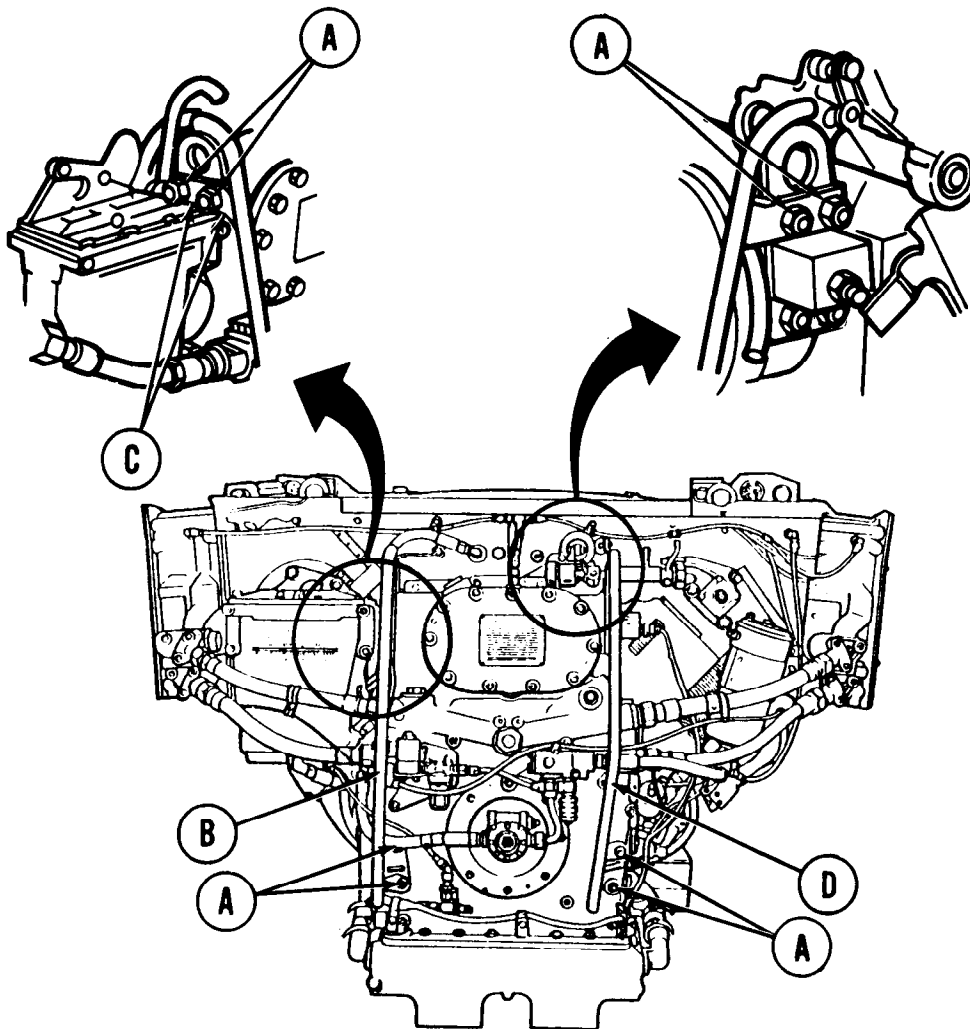

1. Using 9/16 inch open end wrench, remove four nuts and washers (A) securing left guide (B) to engine.
2. Remove clamps (C).
3. Remove left guide (B).
4. Using 9/16 inch socket, remove four nuts and washers (A) securing right guide (D) to engine.
5. Remove right guide (D).

Go on to Sheet 3

TA108234

ENGINE REPLACEMENT**Accessory Drive Removal From Replacement Engine (Sheet 3 of 6)**

6. Using 7/8 inch open end wrench and 3/4 inch open end wrench, remove hose assembly (E) between fuel pump (F) and fuel-water separator (G). Use rags to soak up leaking fluid.
7. Using 7/8 inch open end wrench and 3/4 inch open end wrench, remove hose assembly (H) between fuel check valve (J) and primary fuel filter (K). Use rags to soak up leaking fluid.

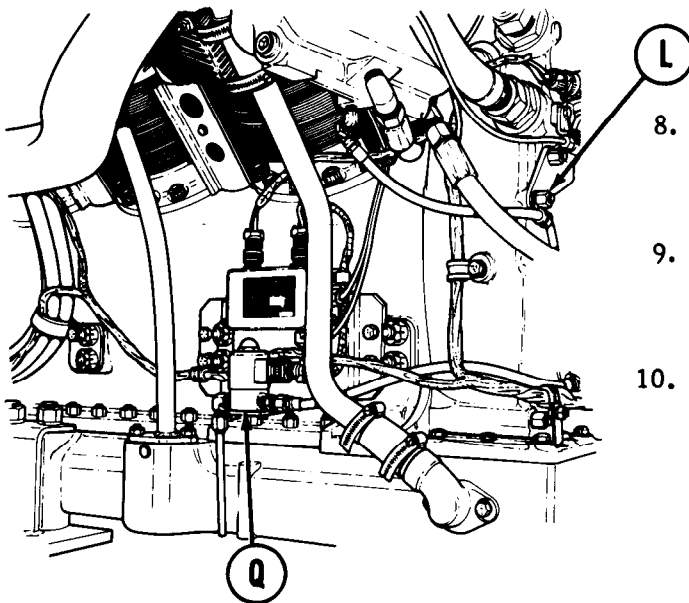
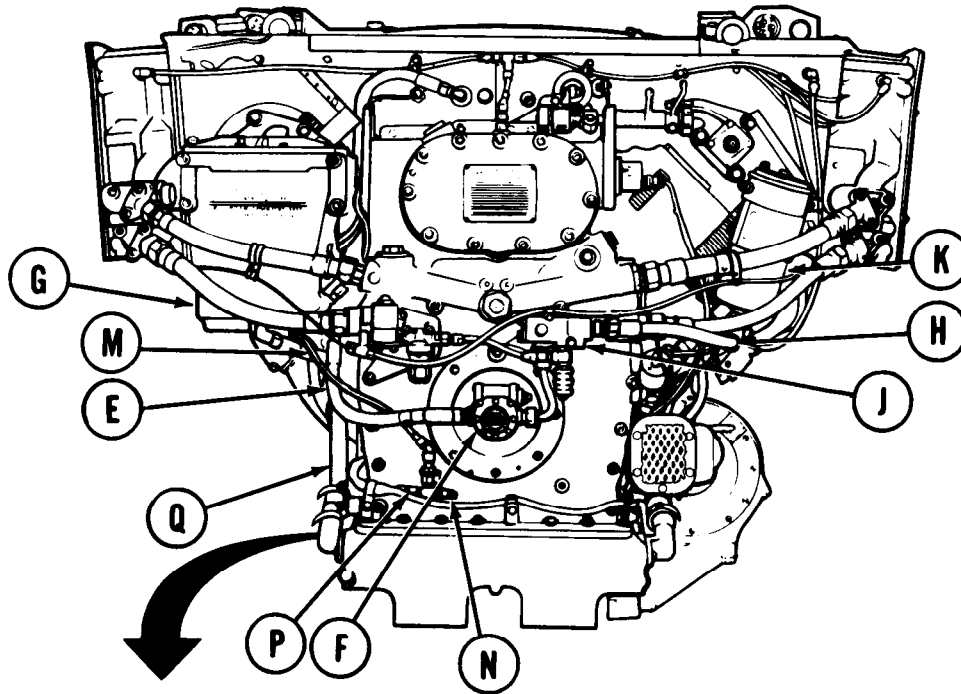

8. Using 9/16 inch open end wrench, remove nut (L) securing clamp on hose assembly (M).
9. Using 9/16 inch open end wrench, remove hose assembly (M) between fuel-water separator (G) and drain cock (N).
10. Using 9/16 inch open end wrench, remove hose assembly (P) between drain cock (N) and fuel-water separator solenoid valve (Q).

Go on to Sheet 4

TA108235

ENGINE REPLACEMENT

Accessory Drive Removal From Replacement Engine (Sheet 4 of 6)

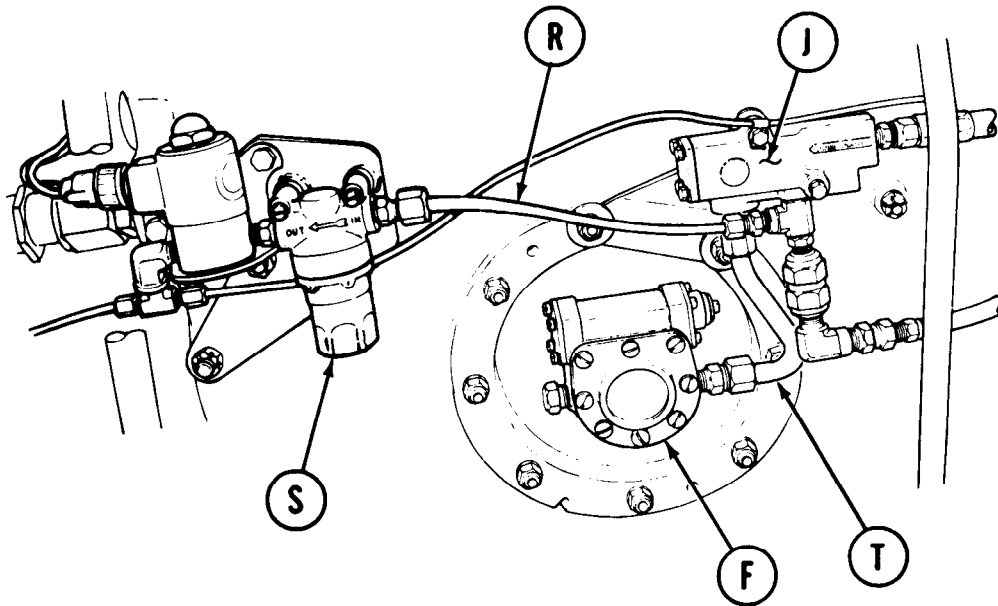

11. Using 5/8 inch open end wrench, remove tube assembly (R) between fuel filter (S) and fuel check valve (J).
12. Using 7/8 inch open end wrench, remove tube assembly (T) between fuel pump (F) and fuel check valve (J).
13. Using 9/16 inch open end wrench, remove nut (U) securing bracket (V) to engine.
14. Remove bracket (V) with nut (W), connector (X), tee (Y), and cock (N) attached.
15. Using stud remover/installer, remove stud (Z) from engine housing.

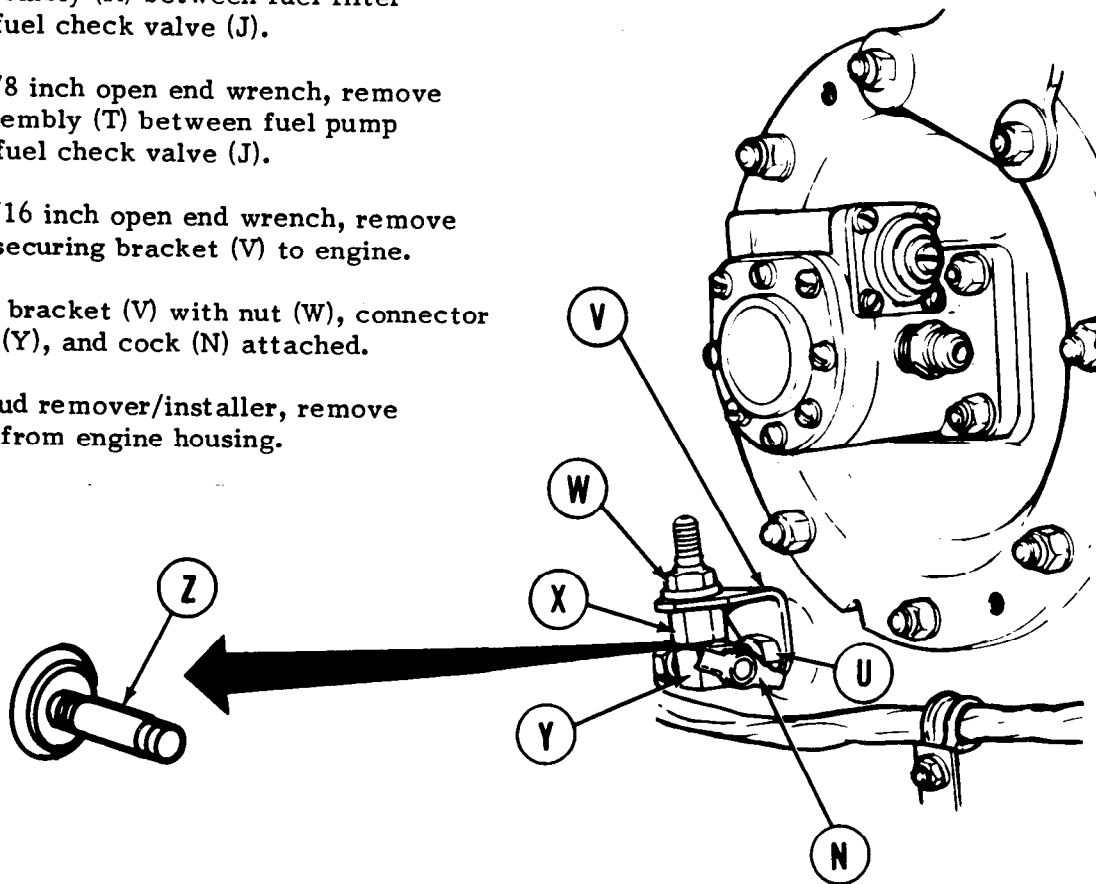

Go on to Sheet 5

TA108236

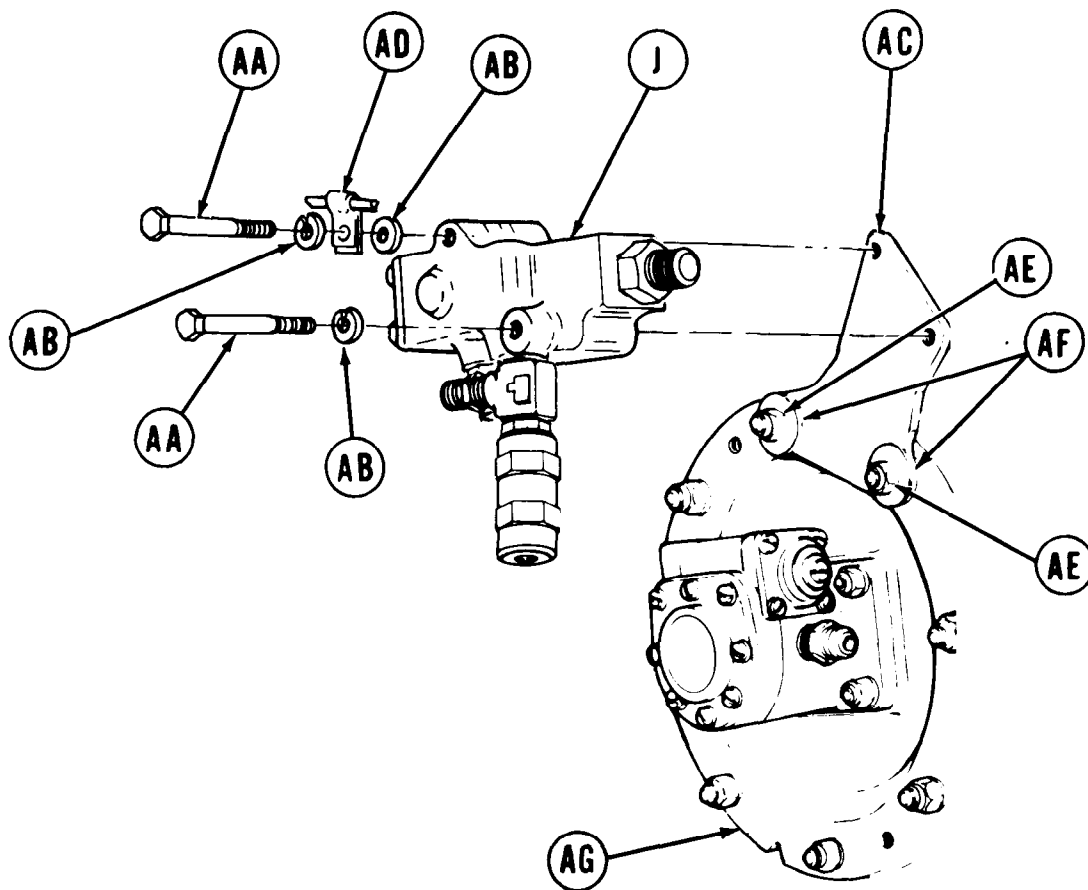
ENGINE REPLACEMENT**Accessory Drive Removal From Replacement Engine (Sheet 5 of 6)**

16. Using 7/16 inch socket, remove screw (AA) and washer (AB) that secure check valve assembly (J) to bracket (AC).
17. Remove screw (AA), washers (AB), and clamp (AD) that secure check valve assembly (J) to bracket (AC).
18. Using 9/16 inch socket, remove two nuts (AE) and two washers (AF) that secure bracket (AC) to adapter (AG).

Go on to Sheet 6

TA108237

ENGINE REPLACEMENT

Accessory Drive Removal From Replacement Engine (Sheet 6 of 6)

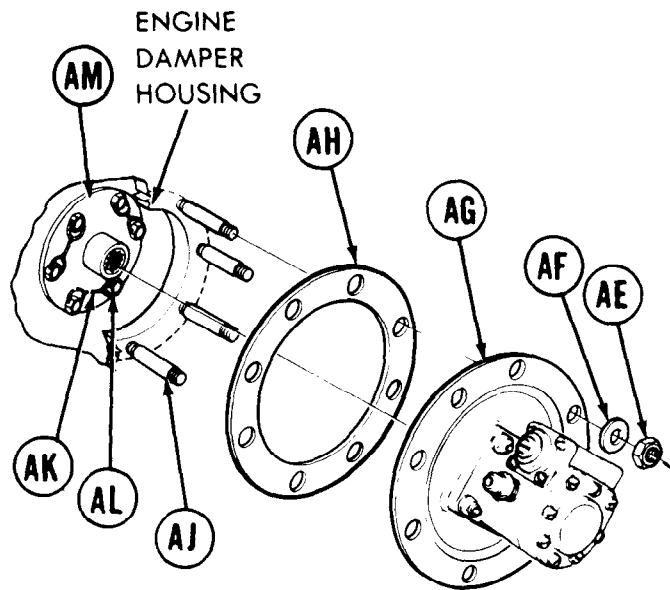

19. Using 9/16 inch socket, remove remaining six nuts (AE) and washers (AF) that secure adapter (AG) and gasket (AH) to engine damper housing. Throw away gasket (AH).
20. Using stud remover/installer, remove eight studs (AJ).

NOTE

Use clean rags in bottom of engine damper housing to catch pieces of gasket and lockwire. They must NOT fall into engine.

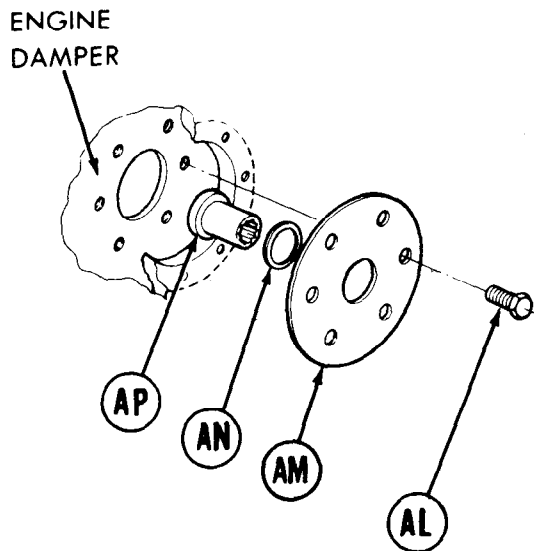

21. Using putty knife, scrape all remaining traces of gasket material or adhesive from mounting surface of engine damper housing.
22. Using wire cutting pliers, cut and remove lockwire (AK) from six screws (AL) that secure adapter (AM) to engine damper.
23. Using 13/16 inch socket and extension, remove six screws (AL) that secure adapter (AM) to engine damper.

24. Remove adapter (AM), ring (AN), and coupling (AP) from engine damper.

NOTE

Remove ring (AN) from adapter (AM) only if necessary.

End of Task

TA108238

ENGINE REPLACEMENT**Power Takeoff Removal From Unserviceable Engine (Sheet 1 of 10)****NOTE**

Replacement engines are received without the power takeoff unit installed. The power takeoff and associated hardware must be removed from an unserviceable engine and installed on a serviceable engine. The following instructions are for removal of the power takeoff from an unserviceable engine.

TOOLS: Ratchet with 1/2 in. drive
7/16 in. socket with 1/2 in. drive
9/16 in. socket with 1/2 in. drive
5/8 in. socket with 1/2 in. drive (2 required)
3/4 in. socket with 1/2 in. drive
13/16 in. socket with 1/2 in. drive
9/16 in. combination box and open end wrench
5/8 in. combination box and open end wrench
3/4 in. combination box and open end wrench
13/16 in. combination box and open end wrench
7/8 in. combination box and open end wrench
5/16 in. allen wrench
8 in. pipe wrench
Wire cutting pliers
8 in. socket wrench extension with 1/2 in. drive
Stud remover/installer

SUPPLIES: Clean rags

REFERENCE: TM 5-5420-226-20

NOTE

Retain all parts removed during this task for later installation on replacement engine.

Go on to Sheet 2

ENGINE REPLACEMENT

Power Takeoff Removal From Unserviceable Engine (Sheet 2 of 10)

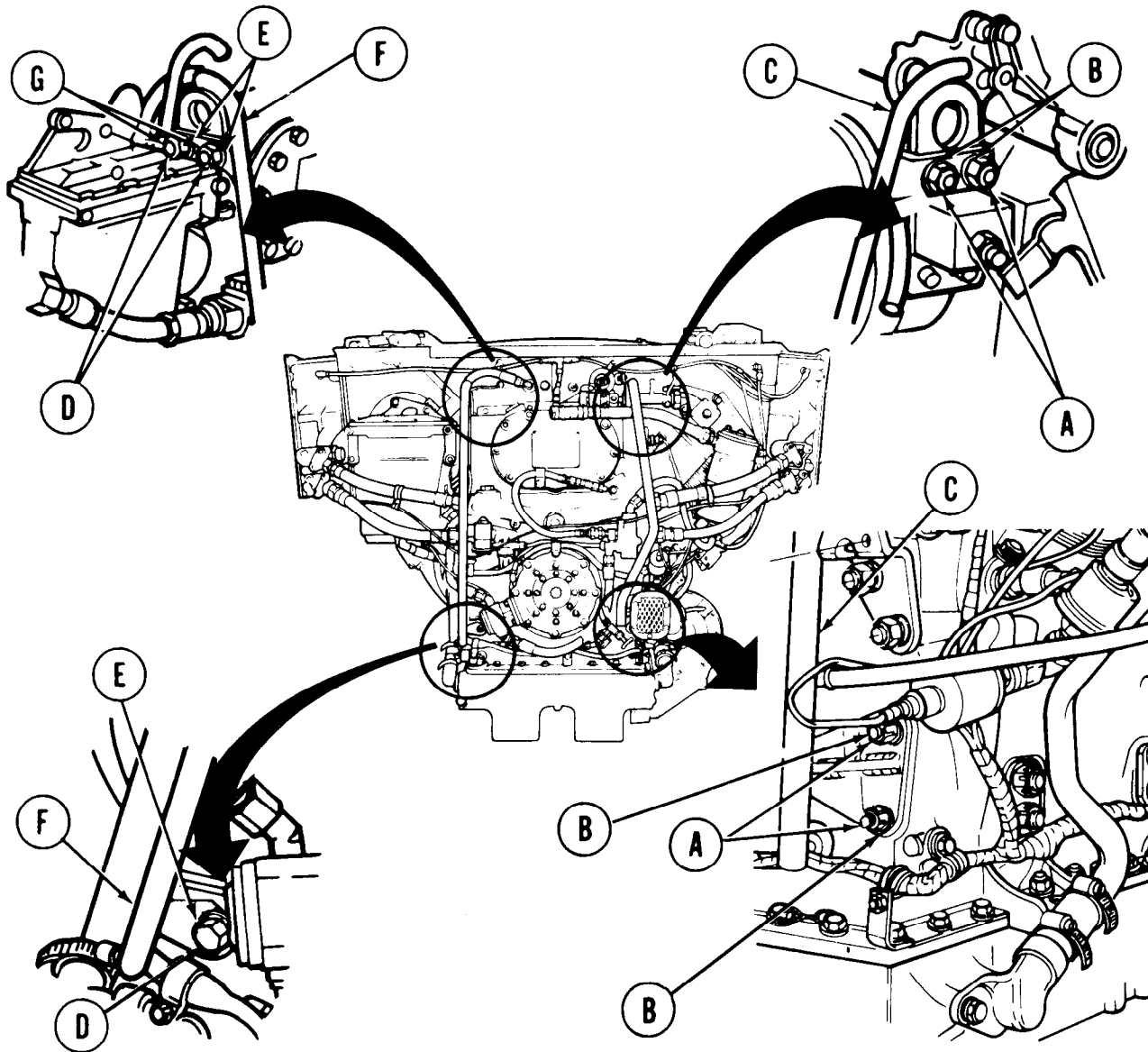

1. Using 9/16 inch open end wrench, remove four nuts (A) and washers (B) securing right guide (C) to engine.
2. Remove right guide (C) from engine.
3. Using 9/16 inch open end wrench, remove three nuts (D) and washers (E) securing left guide (F) to engine.
4. Remove harness clamps (G) from studs.
5. Remove left guide (F).

Go on to Sheet 3

TA108240

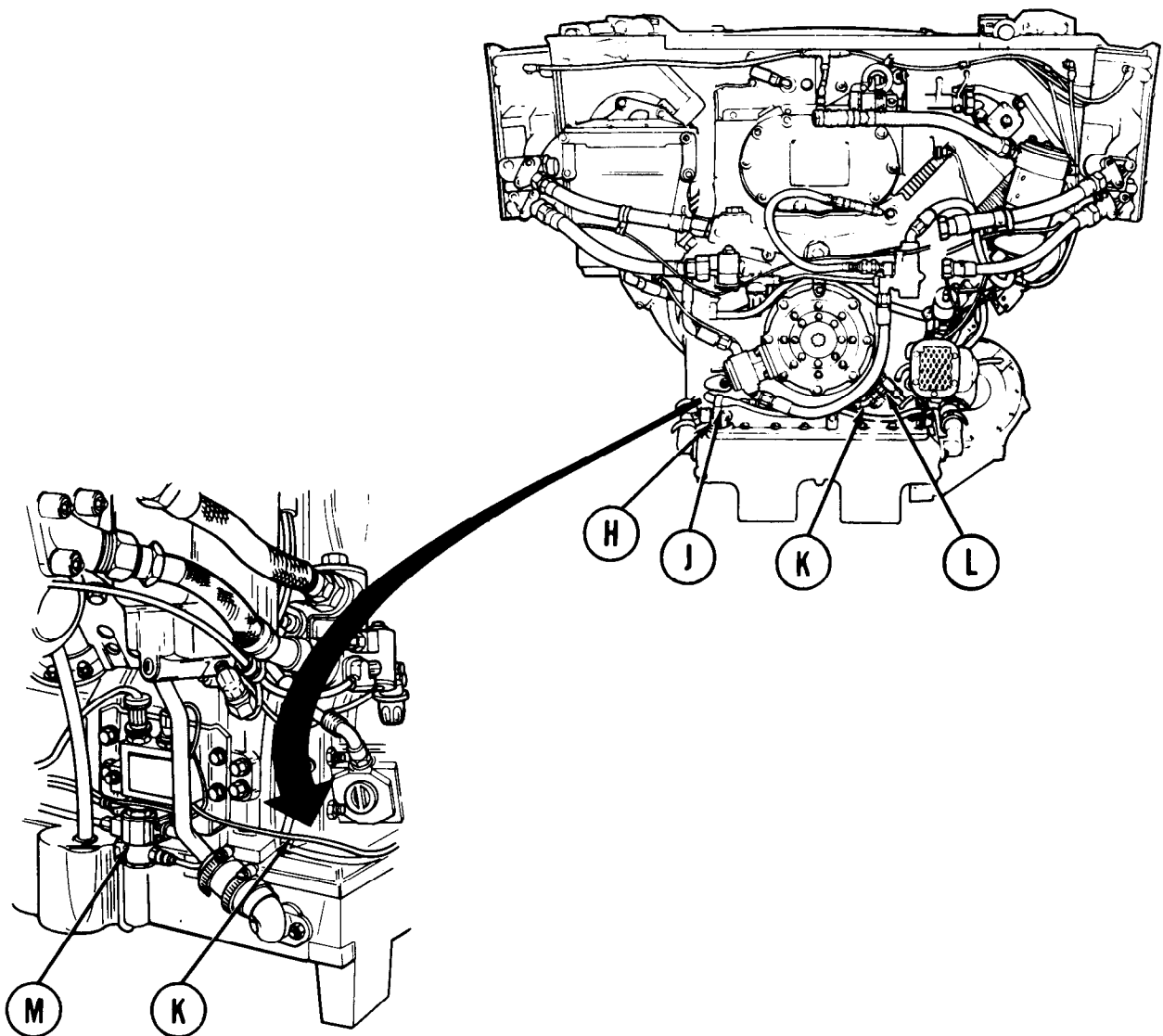
ENGINE REPLACEMENT**Power Takeoff Removal From Unserviceable Engine (Sheet 3 of 10)**

6. Using 9/16 inch socket, remove nut and washer (H) securing clamp (J) and hose (K) to engine housing stud.
7. Using 9/16 open end wrench, remove hose assembly (K) connected between leg of tee-cock assembly (L) and water separator solenoid (M).

Go on to Sheet 4

TA108241

ENGINE REPLACEMENT

Power Takeoff Removal From Unserviceable Engine (Sheet 4 of 10)

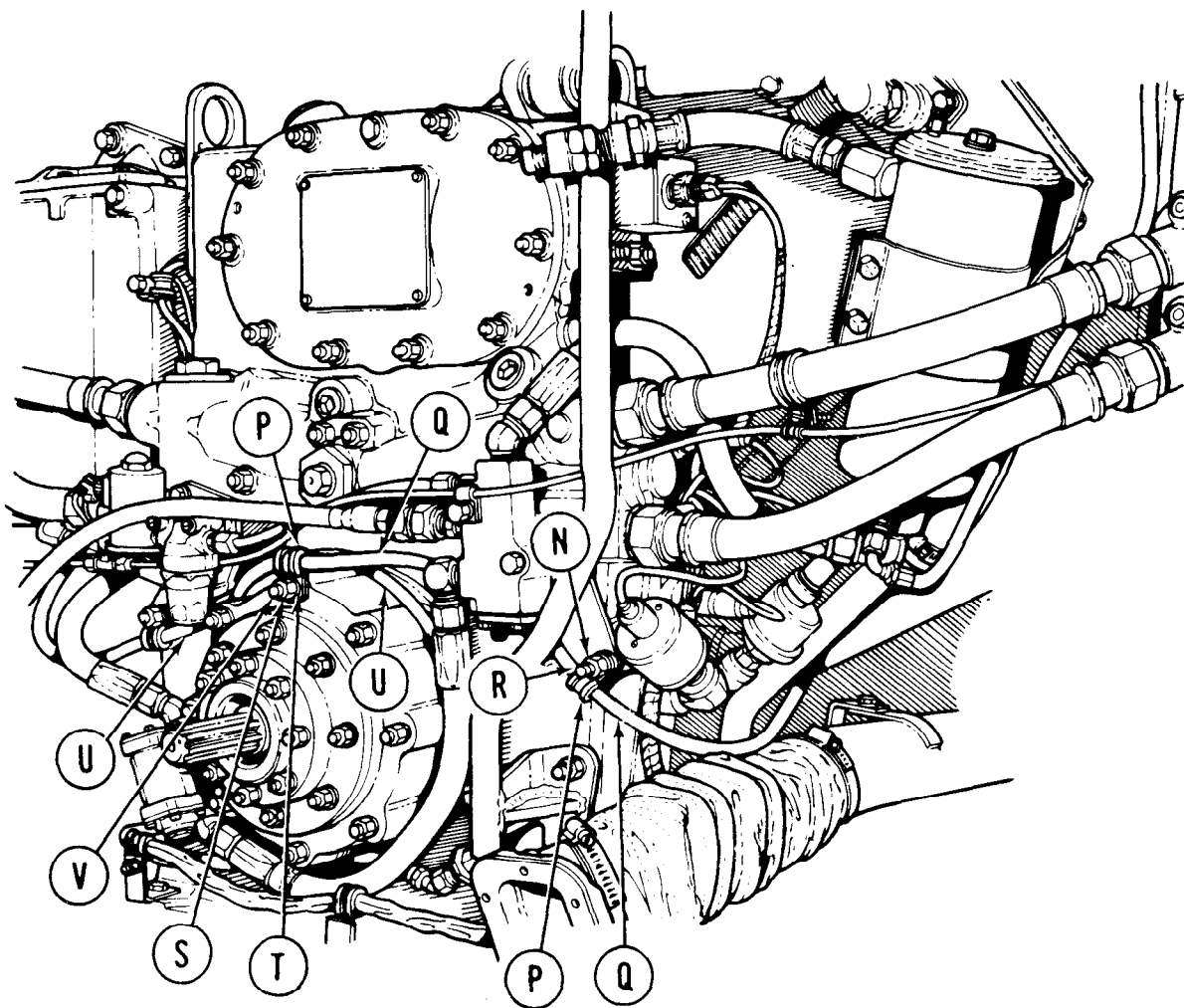

8. Using 9/16 inch socket, remove nut (N) securing clamp (P) and hose (Q) to engine stud (R). Remove clamp (P) from stud (R).
9. Using 9/16 inch socket, remove nut (S) and washer (T) securing clamps (P) and hose (U) to topmost mounting stud (V) of power takeoff. Remove clamp (P) from stud (V).

Go on to Sheet 5

TA108242

ENGINE REPLACEMENT

Power Takeoff Removal From Unserviceable Engine (Sheet 5 of 10)

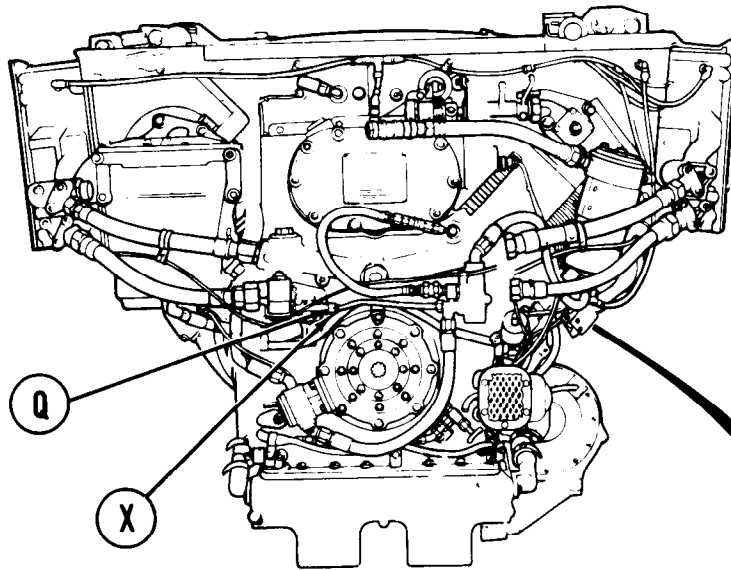

10. Using 9/16 inch open end wrench, remove hose assembly (Q) between elbow (W) and 45- degree elbow (X) mounted on power takeoff assembly.
11. Using 3/4 inch wrench, remove bushing (Y) and attached elbow (W) from oil port (Z).

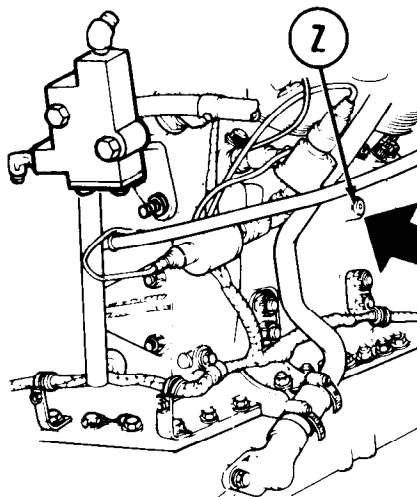
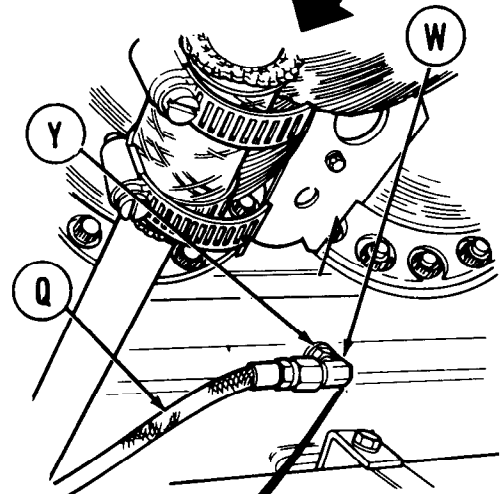

Go on to Sheet 6

TA108243

ENGINE REPLACEMENT

Power Takeoff Removal From Unserviceable Engine (Sheet 6 of 10)

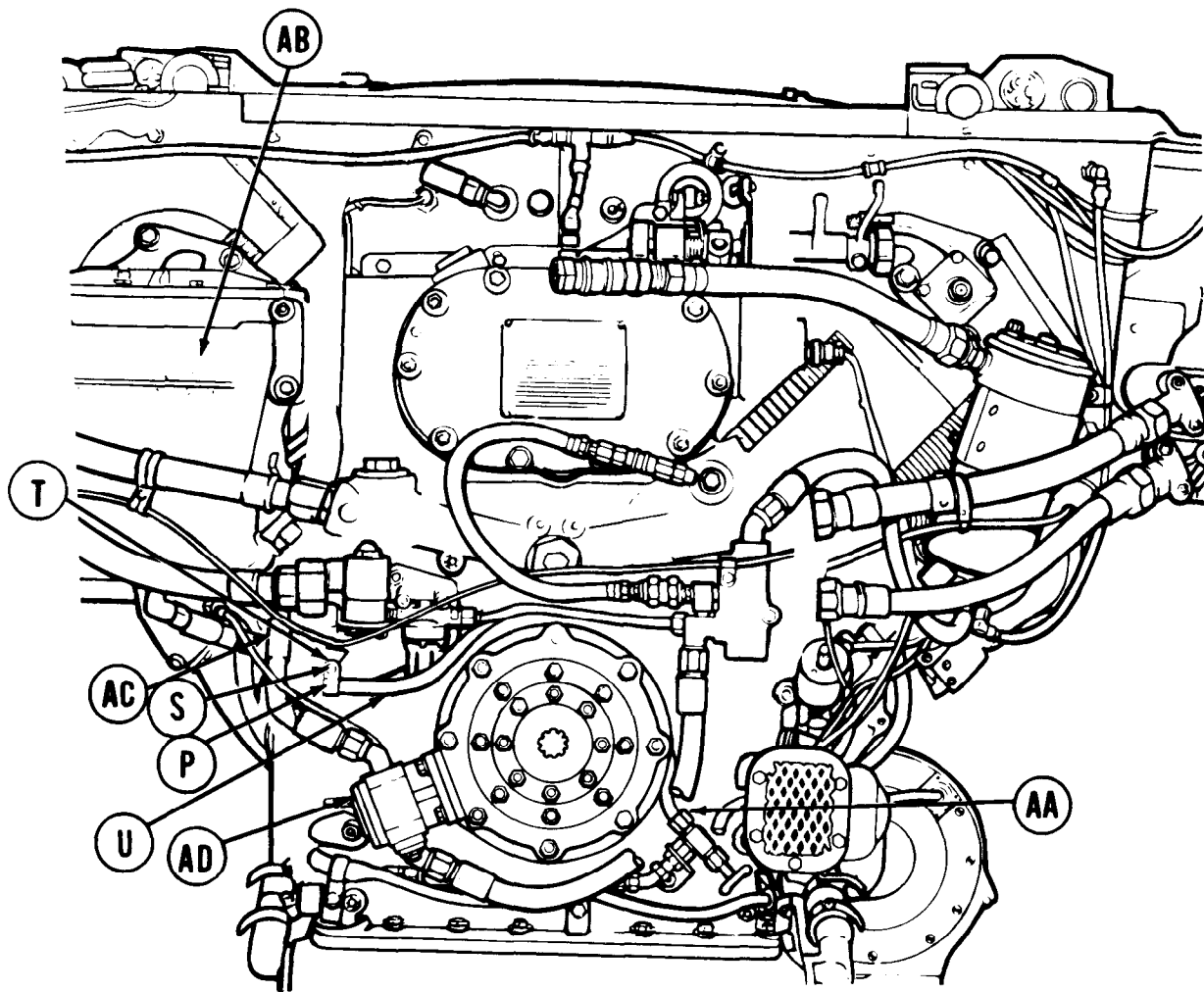

12. Using 9/16 inch socket, remove nut (S) and washer (T) securing clamp (P) and hose assembly (U).
13. Using 9/16 inch open end wrench, remove hose assembly (U) between straight leg of tee-cock assembly (AA) and fuel-water separator (AB).
14. Using 7/8 inch and 3/4 inch open end wrenches, remove hose assembly (AC) between fuel-water separator (AB) and fuel pump (AD).

Go on to Sheet 7

TA108244

ENGINE REPLACEMENT
Power Takeoff Removal From Unserviceable Engine (Sheet 7 of 10)

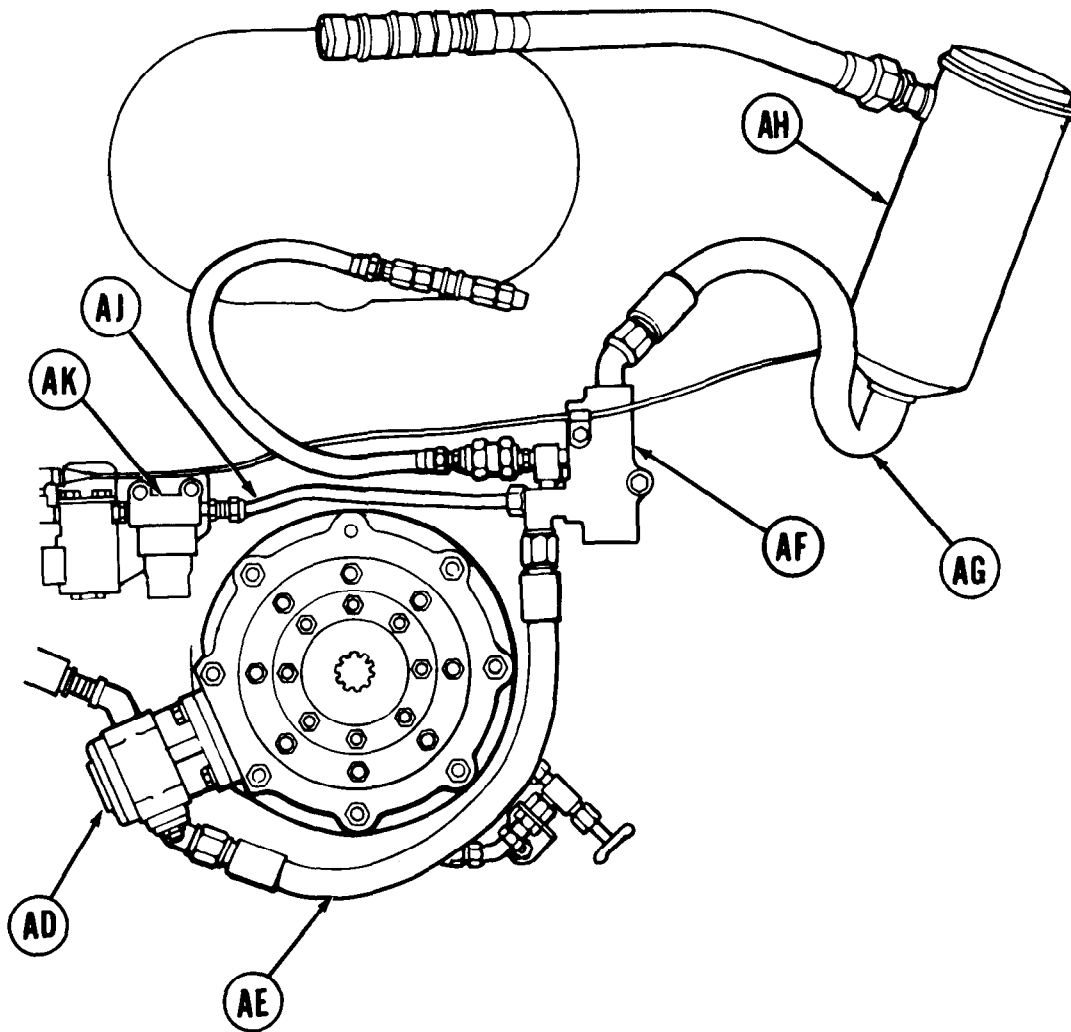

15. Using 7/8 inch and 3/4 inch open end wrenches, remove hose assembly (AE) between fuel pump (AD) and check valve (AF).
16. Using 7/8 and 3/4 inch open end wrenches, remove hose assembly (AG) between check valve (AF) and primary fuel filter (AH).
17. Using 5/8 inch open end wrench, remove plastic fuel tube (AJ) between fuel filter (AK) and check valve (AF).

Go on to Sheet 8

TA108245

ENGINE REPLACEMENT

Power Takeoff Removal From Unserviceable Engine (Sheet 8 of 10)

18. Using 9/16 inch socket, remove remaining seven nuts (S) and washers (T) securing power takeoff (AL) to engine mounting studs (V).
19. Remove power takeoff (AL) from engine mounting studs (V).
20. Remove gasket (AM) from engine mounting studs (V) on engine housing.

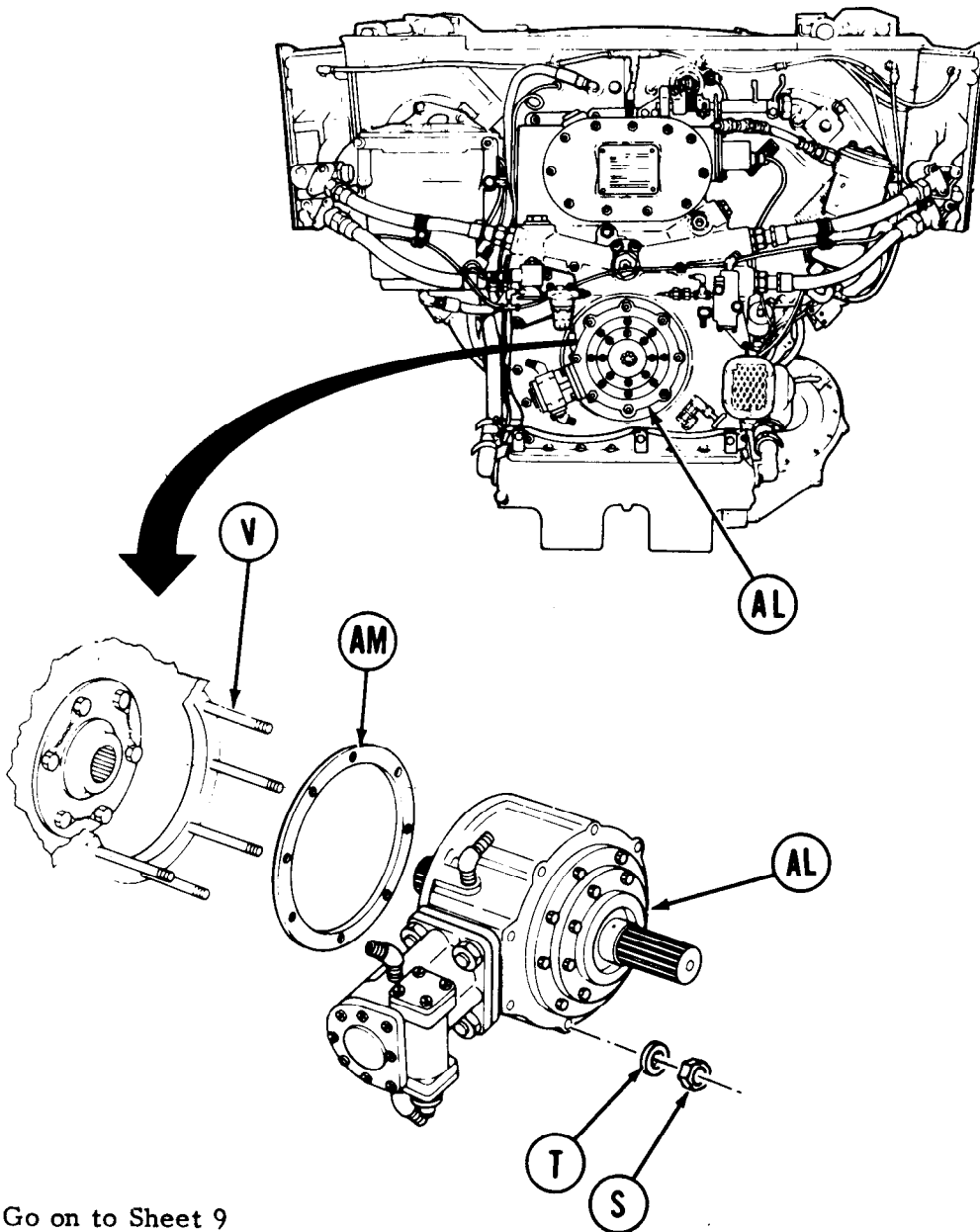

Go on to Sheet 9

TA108246

ENGINE REPLACEMENT**Power Takeoff Removal From Unserviceable Engine (Sheet 9 of 10)**

21. Using 9/16 inch open end wrench, remove nut (S) securing bracket and cock assembly (AN) onto short stud (AP).
22. Using 7/16 inch socket, remove two screws (AQ), three washers (AR), and clamp (AS) securing check valve (AF) to bracket (AT).

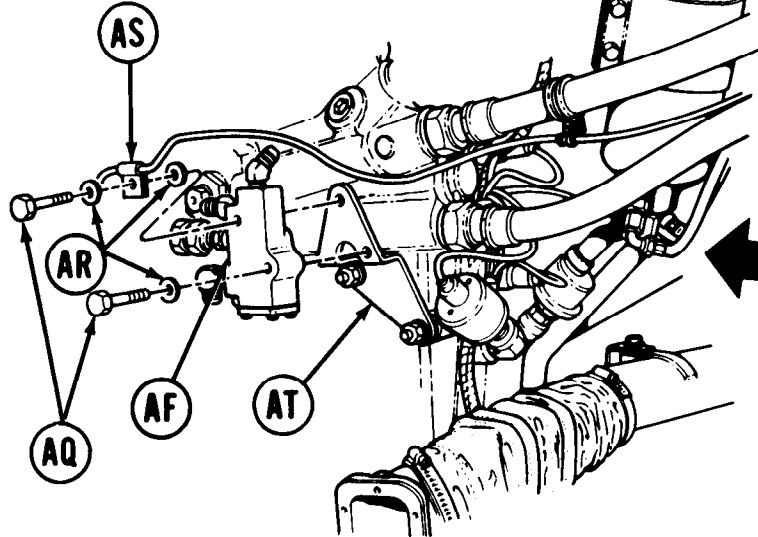
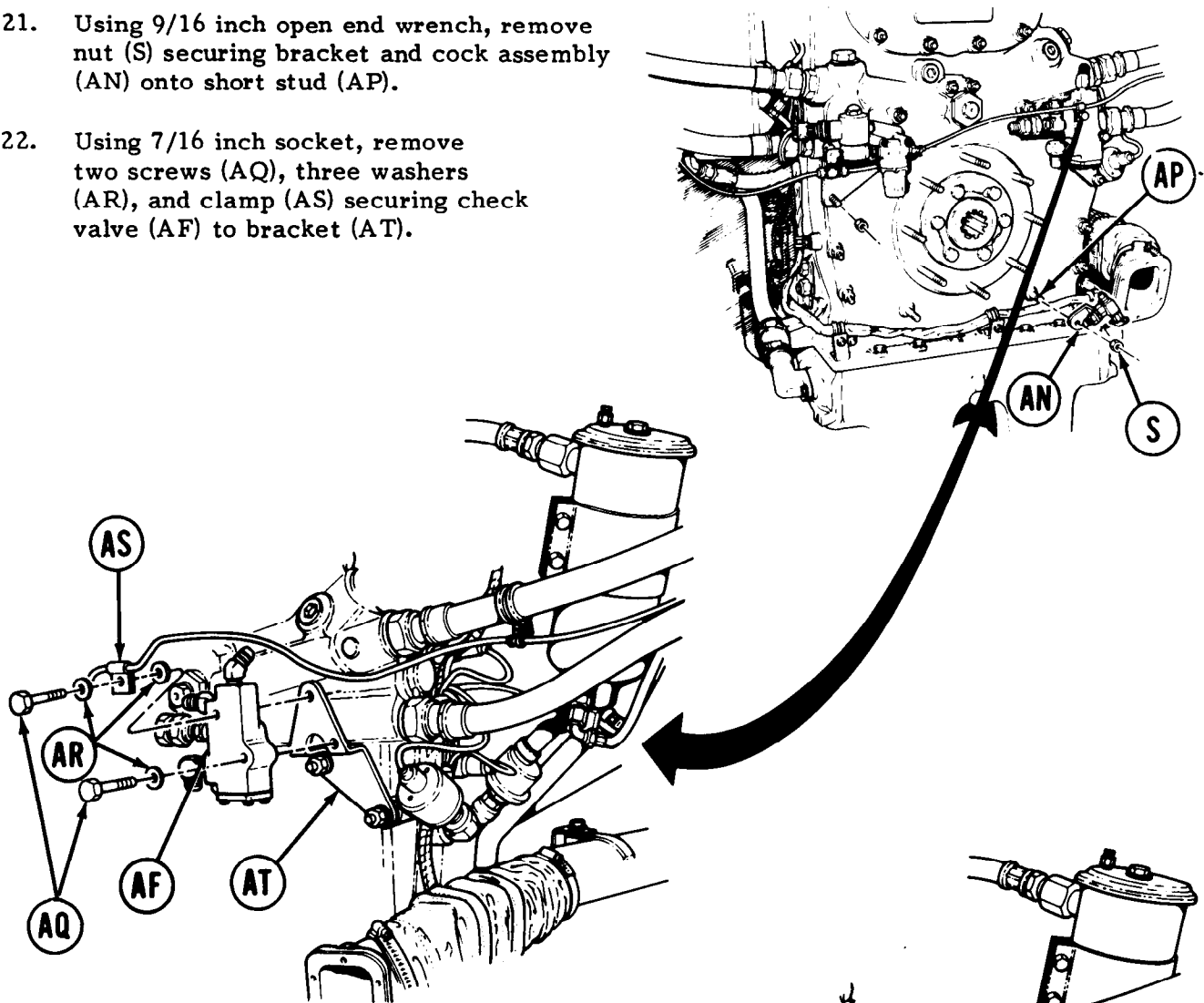

23. Using 9/16 inch socket, remove nuts (S) and washers (T) securing bracket (AT) to studs (AU) on engine housing.
24. Using stud remover/installer, remove studs (AU).

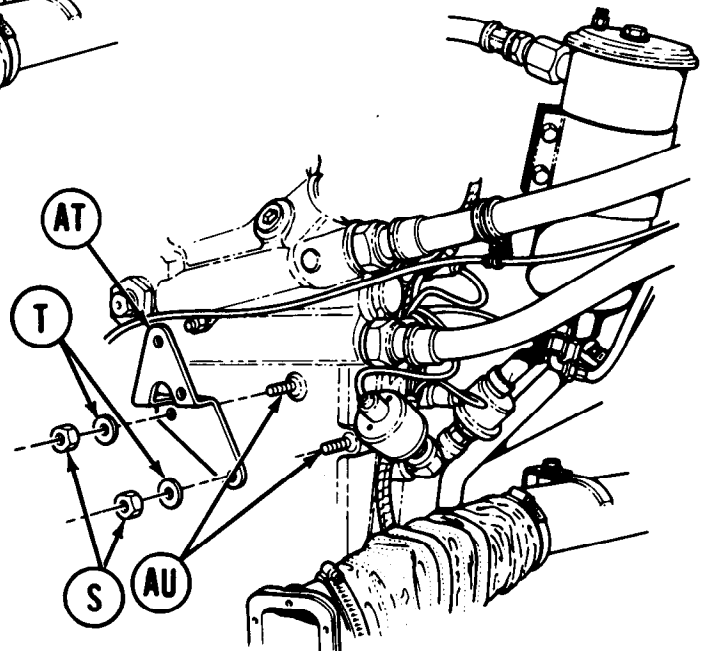

Go on to Sheet 10

TA108247

ENGINE REPLACEMENT

Power Takeoff Removal From Unserviceable Engine (Sheet 10 of 10)

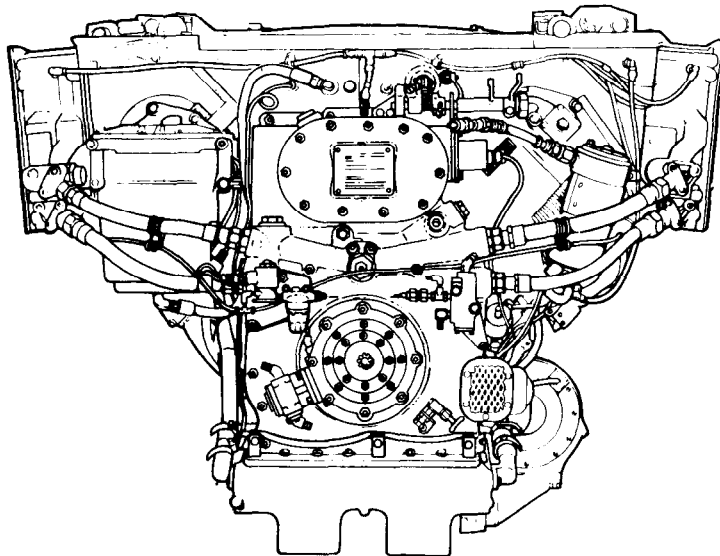

25. Using stud remover/installer, remove eight studs (V).
26. Using wire cutting pliers, remove lockwire (AV).
27. Using 13/16 inch socket and 8 inch extension, remove six screws (AW) securing adapter (AX) to engine damper.
28. Remove adapter (AX) from engine damper.

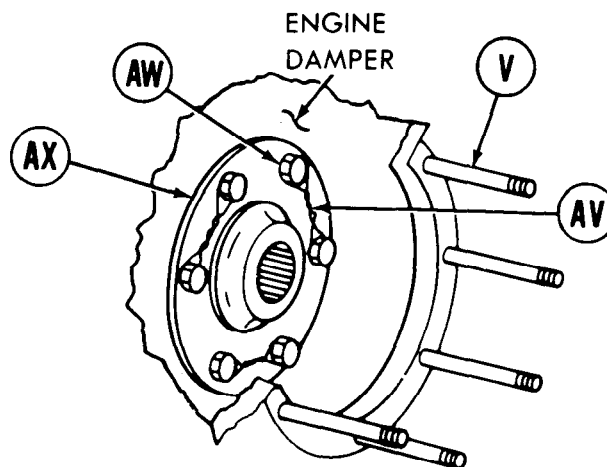

End of Task

TA108248

ENGINE REPLACEMENT**Power Takeoff Installation On Replacement Engine (Sheet 1 of 11)****NOTE**

Replacement engines are received without the power takeoff unit installed. The power takeoff and associated hardware must be removed from the unserviceable engine. The following instructions are for installation of the power takeoff on a replacement engine.

TOOLS: Torque wrench with 1/2 in. drive (0-200 lb-ft) (0-136 N·m)
Ratchet with 1/2 in. drive
7/16 in. socket with 1/2 in. drive
1/2 in. socket with 1/2 in. drive
9/16 in. socket with 1/2 in. drive
5/8 in. socket with 1/2 in. drive
11/16 in. socket with 1/2 in. drive
3/4 in. socket with 1/2 in. drive
13/16 in. socket with 1/2 in. drive
9/16 in. combination box and open end wrench
5/8 in. combination box and open end wrench
3/4 in. combination box and open end wrench
13/16 in. combination box and open end wrench
7/8 in. combination box and open end wrench
5/16 in. allen wrench
Putty knife
Stud remover/installer
Wire cutting pliers
8 in. adjustable wrench
8 in. socket wrench extension with 1/2 in. drive

SUPPLIES: Power takeoff and attaching parts - removed from unserviceable engine
Clean rags
Locking wire (Item 27, Appendix B)
Sealer - Lock-tite (Item 7, Appendix B)
Pipe tape

REFERENCE: TM 5-5420-226-20

Go on to Sheet 2

ENGINE REPLACEMENT

Power Takeoff Installation On Replacement Engine (Sheet 2 of 11)

1. Place splined adapter (A) in position over mounting holes on engine damper.
2. Using 13/16 inch socket with 8 inch extension and torque wrench, install six screws (B) to secure splined adapter (A) to engine damper. Tighten screws (B) to 67-71 lb-ft (90-96 N.m).
3. Using lockwire (C), wire screws (B) together in pairs as shown.

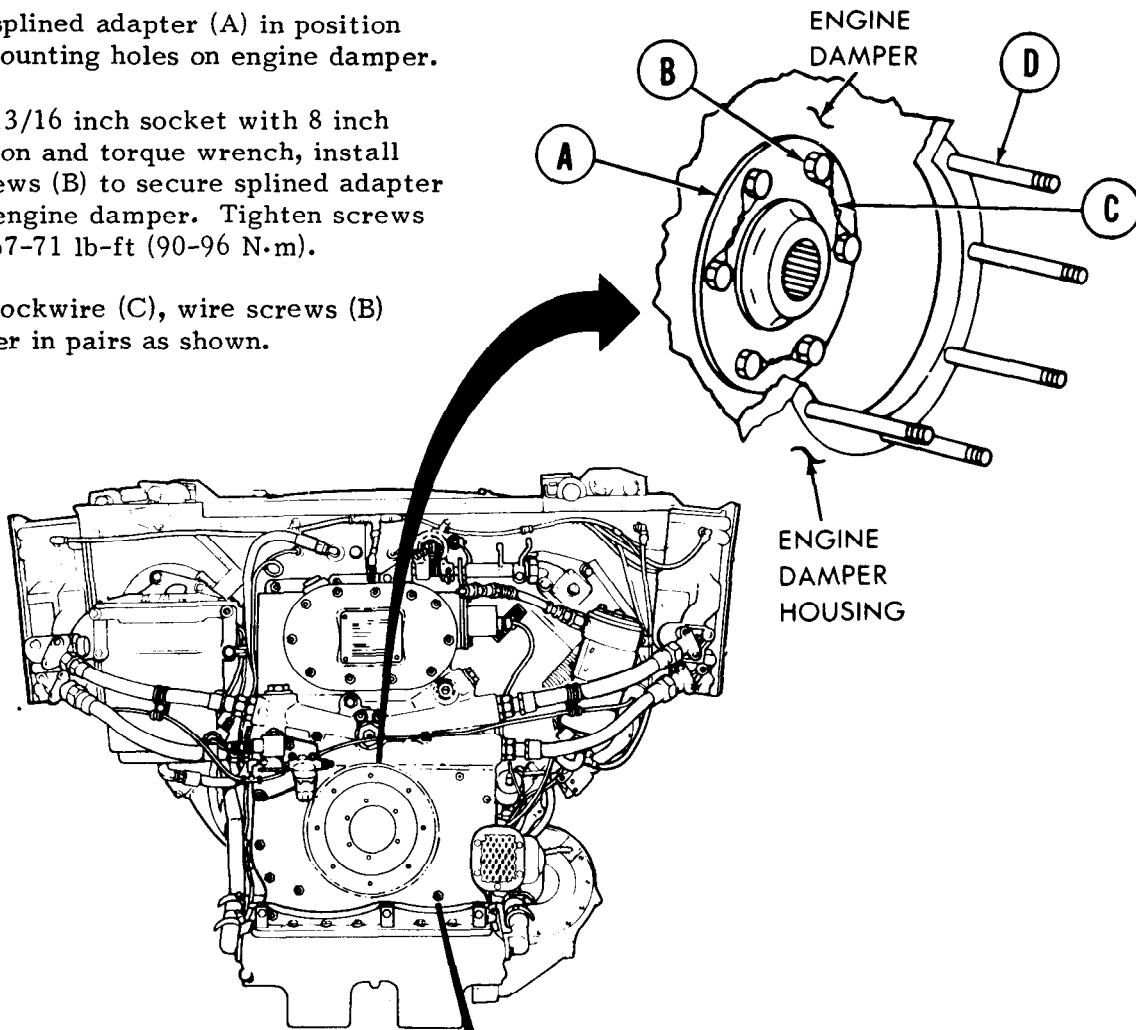

4. Using stud remover/installer, install eight long studs (D) to height of 3-1/2 (8.9 cm) inches in holes in engine damper housing. Both mating threads must be clean and free from oil or grease.
5. Using stud remover/installer, install short stud (E) to height of 11/16 (1.7 cm) inch in mounting hole in engine housing. Both mating threads must be clean and free from oil or grease.

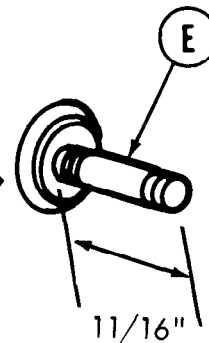

Go on to Sheet 3

TA108250

ENGINE REPLACEMENT

Power Takeoff Installation On Replacement Engine (Sheet 3 of 11)

6. Place check valve mounting bracket (F) in position on studs (G) as shown. Untapped holes of bracket (F) go over studs (G).
7. Using 9/16 inch socket and ratchet, install two washers (H) and two nuts (J) to secure bracket (F) to studs (G) on engine housing.

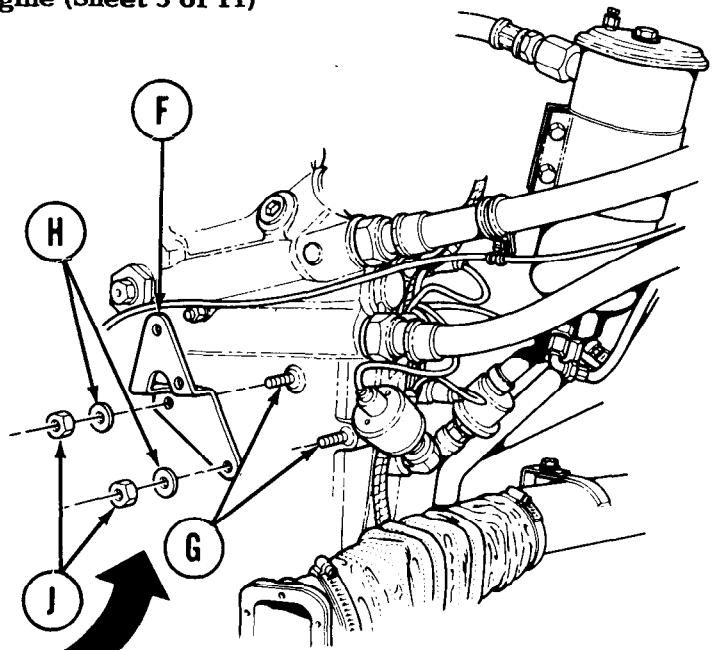
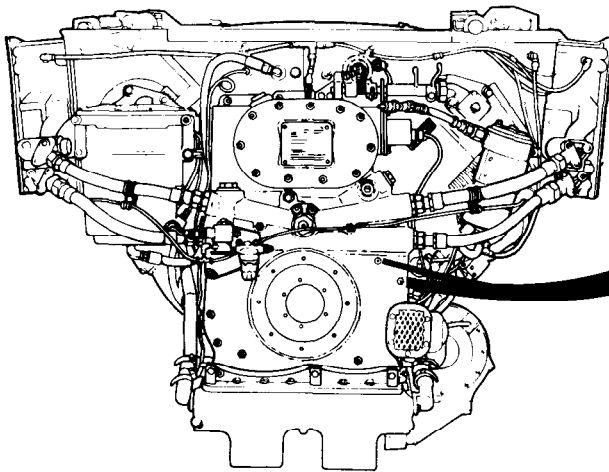

8. Place clamp (K) over plastic fuel line (L).
9. Attach clamp (K) and plastic fuel line (L) to check valve (M) using screw (N) and two washers (P). Insert screw through top mounting hole of valve (M).

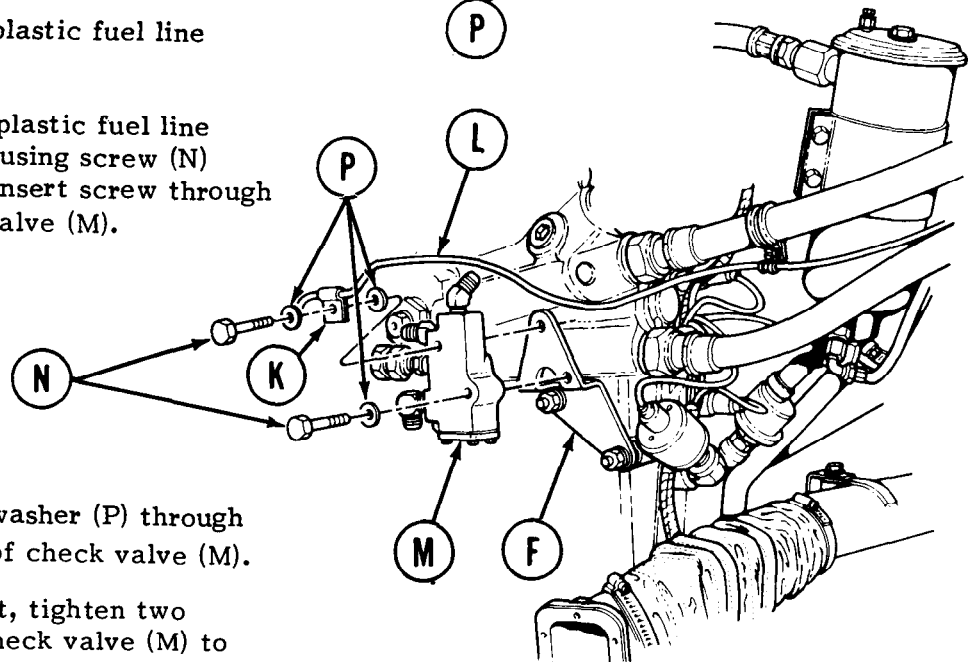
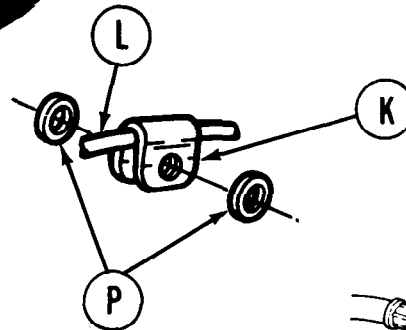

10. Insert screw (N) and washer (P) through lower mounting hole of check valve (M).
11. Using 7/16 inch socket, tighten two screws (N) securing check valve (M) to bracket (F).

Go on to Sheet 4

TA108251

ENGINE REPLACEMENT

Power Takeoff Installation On Replacement Engine (Sheet 4 of 11)

12. Using 9/16 inch combination box and open end wrench, secure bracket and cock assembly (Q) onto short stud (E) with nut (R).

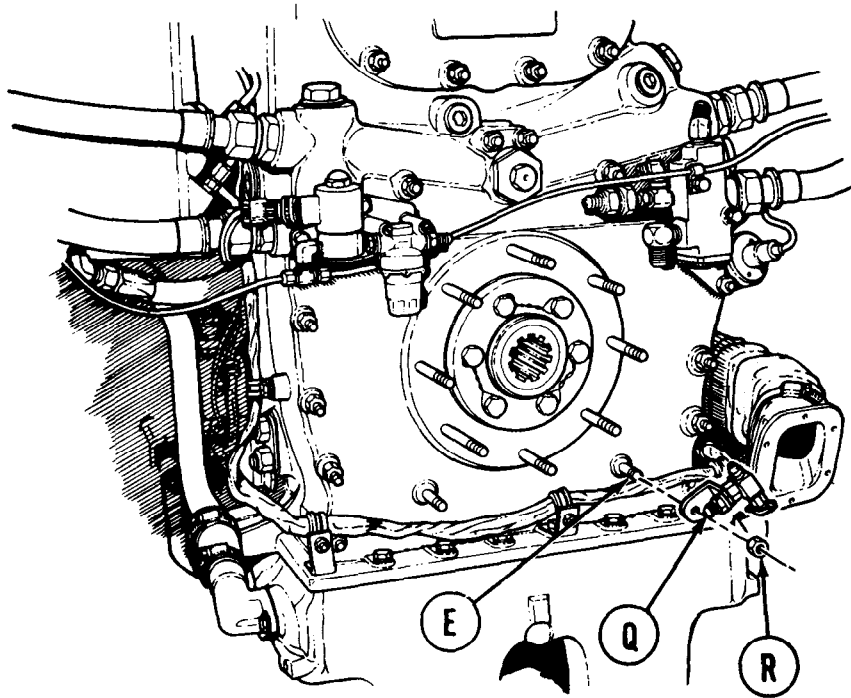

Go on to Sheet 5

TA108252

ENGINE REPLACEMENT

Power Takeoff Installation On Replacement Engine (Sheet 5 of 11)

13. Place gasket (S) in position over mounting studs (D) on engine housing.
14. Place power takeoff (T) in position on engine mounting studs (D). Power takeoff must be positioned so fuel pump (U) is at approximately eight o'clock position.
15. Carefully guide power takeoff short splined input shaft (V) into hole in adapter (A).

NOTE

Do not install the topmost washer (W) and nut (X) on stud (D).

16. Using 9/16 inch socket, secure power takeoff (T) with washers (W) and nuts (X).

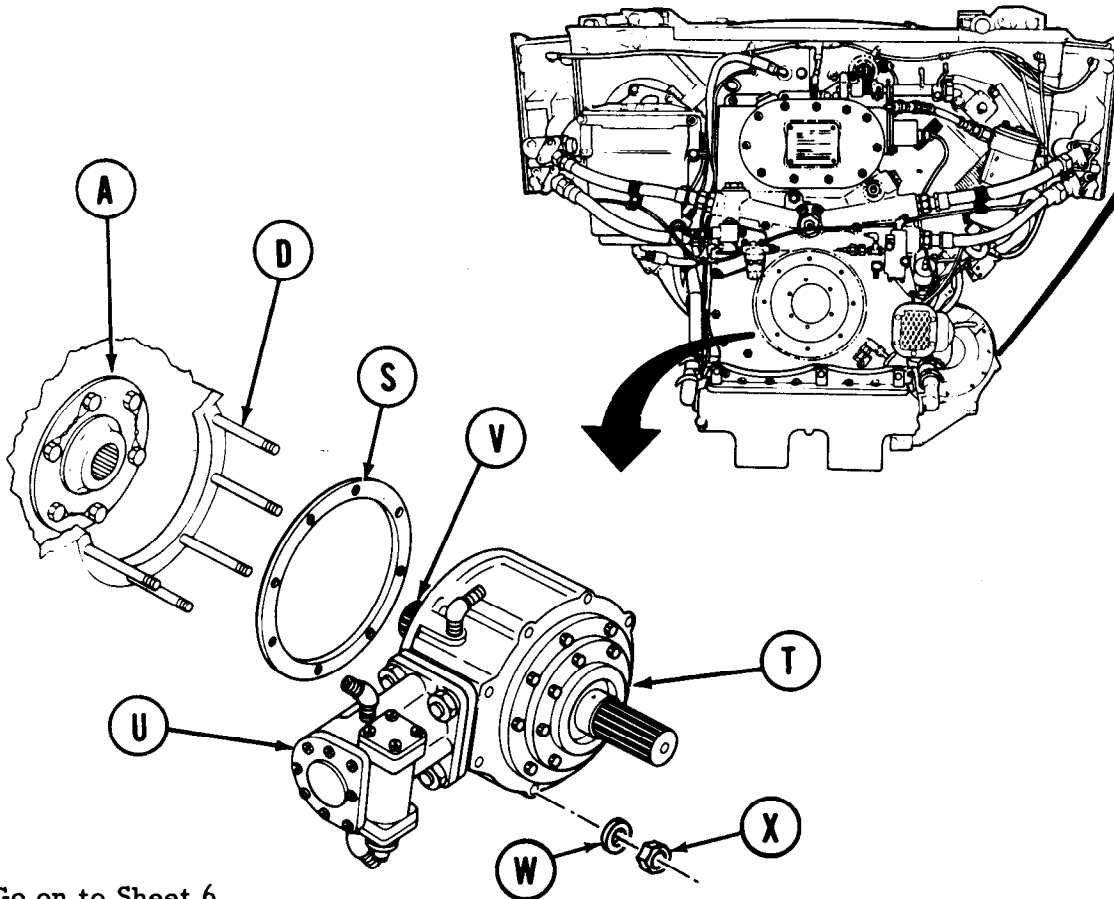
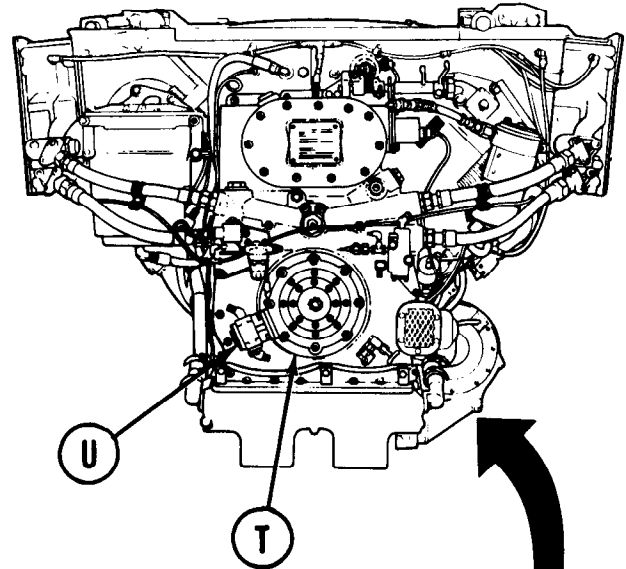

Go on to Sheet 6

TA108253

ENGINE REPLACEMENT

Power Takeoff Installation On Replacement Engine (Sheet 6 of 11)

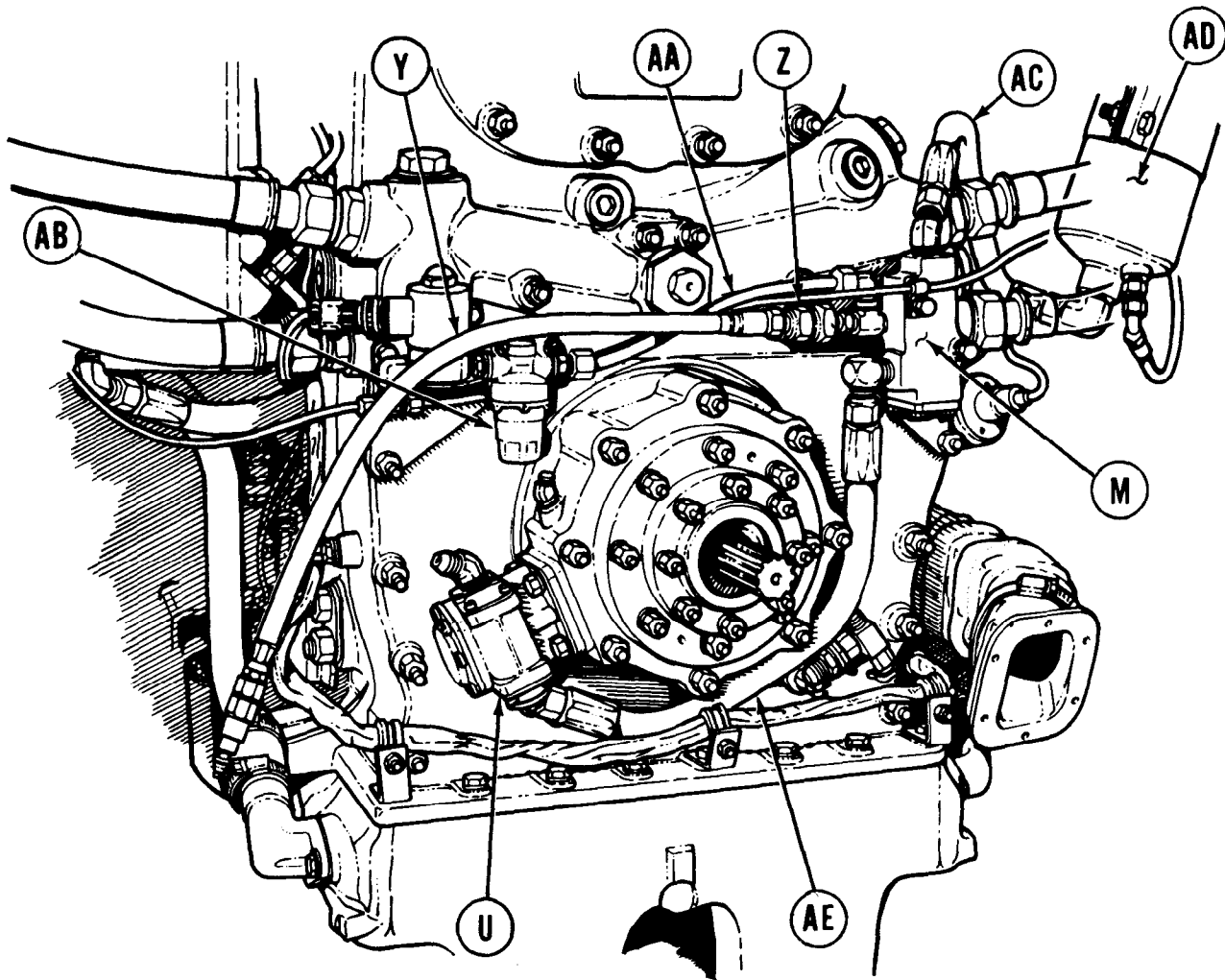

NOTE

Wrap threads of fuel lines with pipe tape prior to installation.

CAUTION

Tape must not extend beyond end of fuel lines to prevent interference with fuel flow.

17. Connect engine fuel primer quick-disconnect line (Y) to fuel check valve filter (Z).
18. Using 5/8 inch open end wrench, connect plastic fuel tube assembly (AA) between fuel filter (AB) and check valve (M).
19. Using 7/8 inch open end wrench, connect hose assembly (AC) between check valve (M) and primary fuel filter (AD).
20. Using 7/8 inch open end wrench, connect hose assembly (AE) between fuel pump (U) and check valve (M).

Go on to Sheet 7

TA108254

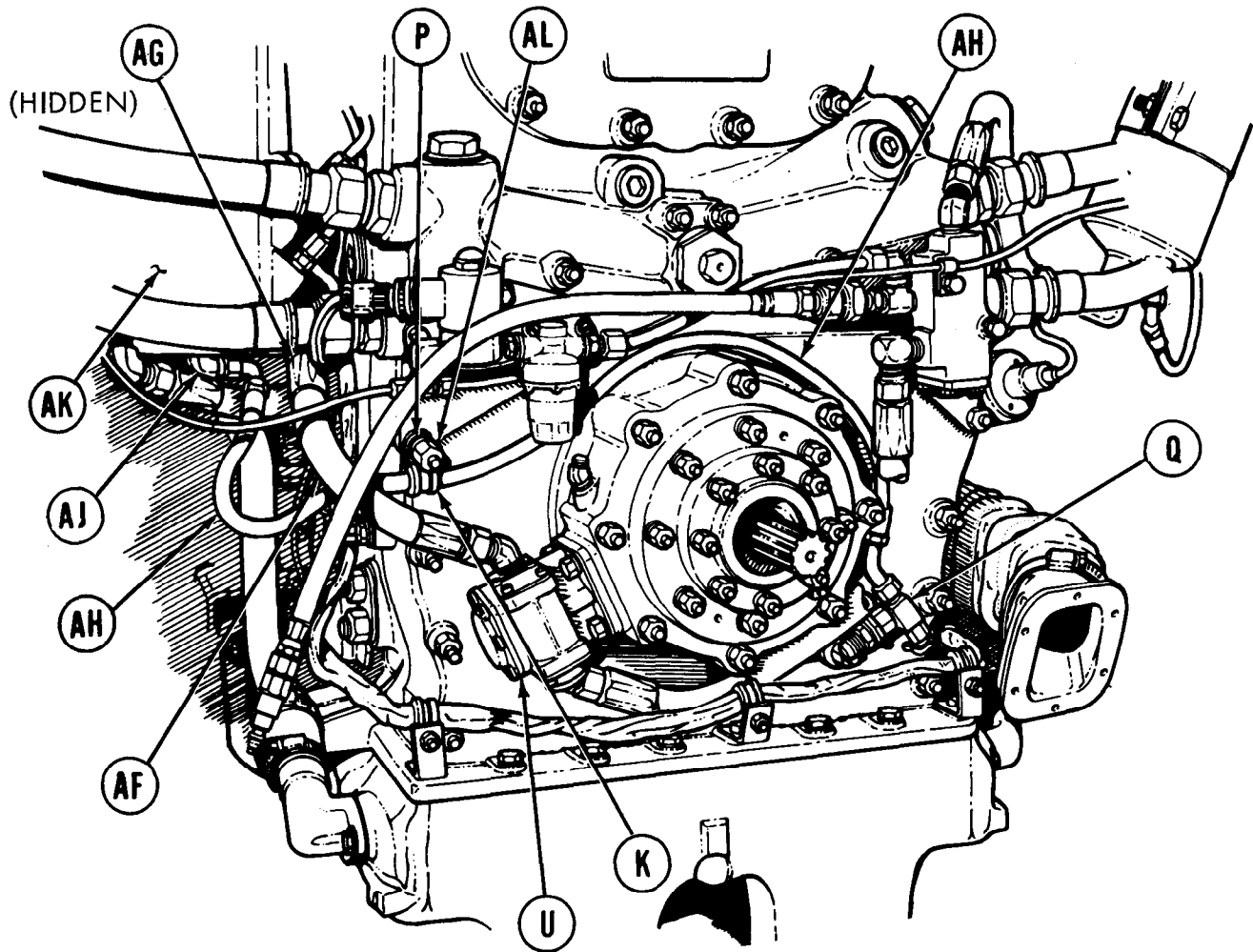
ENGINE REPLACEMENT**Power Takeoff Installation On Replacement Engine (Sheet 7 of 11)**

21. Using 7/8 inch open end wrench, connect hose assembly (AF) between fuel pump (U) and fuel-water separator right hand elbow (AG).
22. Using 9/16 inch open end wrench, connect 90-degree connector of hose assembly (AH) to bottom elbow (AJ) of fuel-water separator (AK).
23. Using 9/16 inch open end wrench, connect 45-degree connector of hose assembly (AH) to straight leg of the tee-cock assembly (Q).
24. Using 9/16 inch socket, secure nut (AL) and washer (P) to hose assembly (AH) on engine housing with clamp (K).

Go on to Sheet 8

TA108255

ENGINE REPLACEMENT

Power Takeoff Installation On Replacement Engine (Sheet 8 of 11)

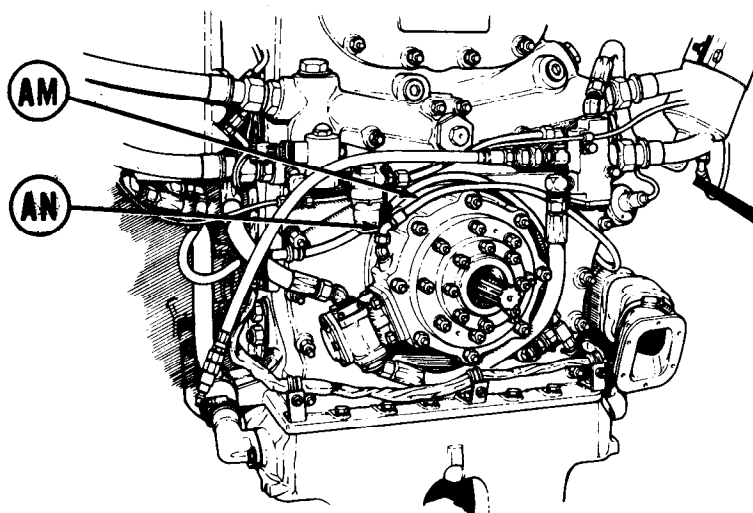

25. Using 9/16 inch open end wrench, connect connector of oil line hose assembly (AM) to 45-degree elbow (AN) in power takeoff oil inlet port.
26. Run hose (AM) around right side of engine to plugged oil port (AP).
27. If plug in port (AP) has socket head, use 5/16 inch allen wrench to remove it. If plug has hexagon head, use 11/16 inch socket to remove it.
28. Using 3/4 inch socket, install bushing (AQ) in oil port (AP).
29. Using adjustable wrench, install elbows (AR) in bushing (AQ).
30. Using 9/16 inch open end wrench, connect hose assembly (AM) to elbow (AR).

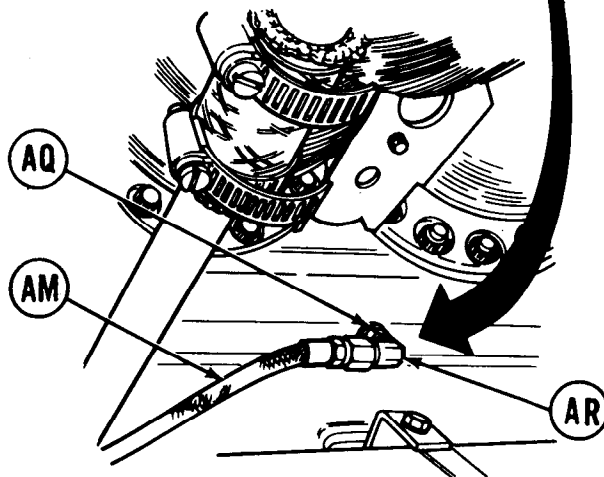
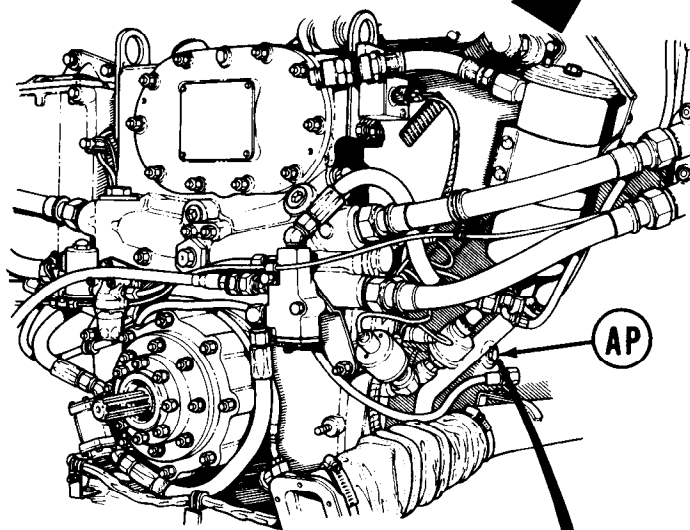

Go on to Sheet 9

TA108256

ENGINE REPLACEMENT
Power Takeoff Installation On Replacement Engine (Sheet 9 of 11)

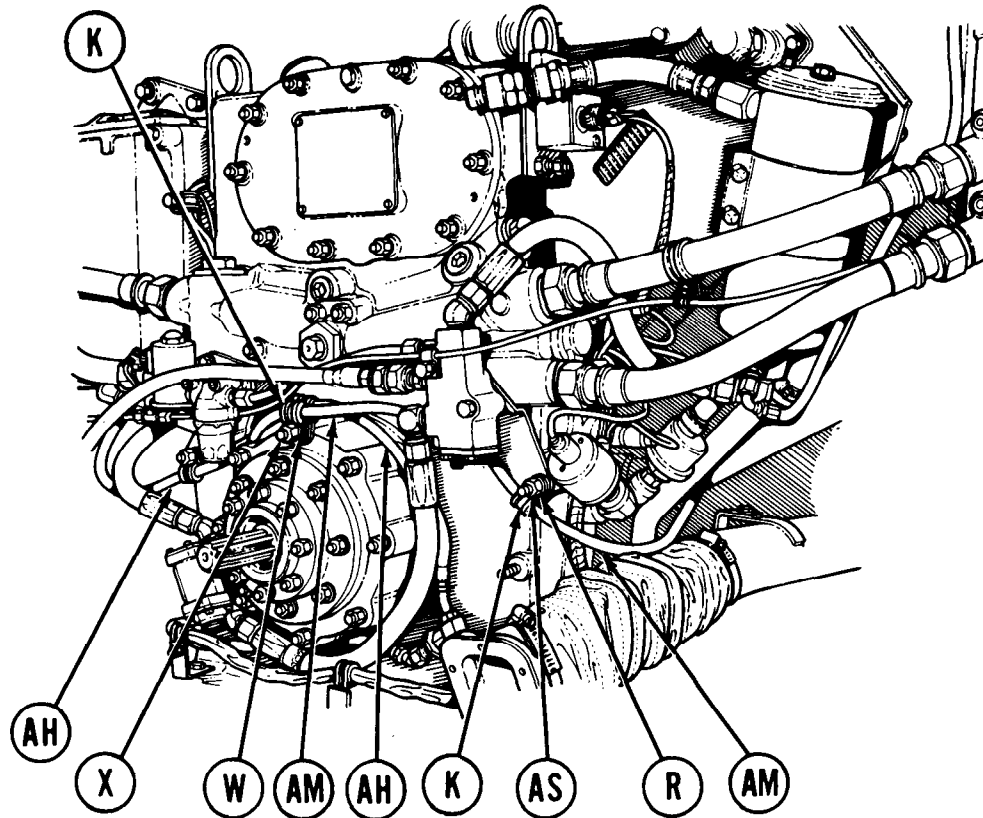

31. Place clamp (K) around hose (AH).
32. Using 9/16 inch socket, secure clamp (K) and hose (AH) to topmost mounting stud of power takeoff with washer (W) and nut (X).
33. Place clamp (K) around hose (AM).
34. Using 9/16 inch socket, secure clamp (K) and hose (AM) to engine stud (AS) with washer and nut (R).

Go on to Sheet 10

TA108257

ENGINE REPLACEMENT

Power Takeoff Installation On Replacement Engine (Sheet 10 of 11)

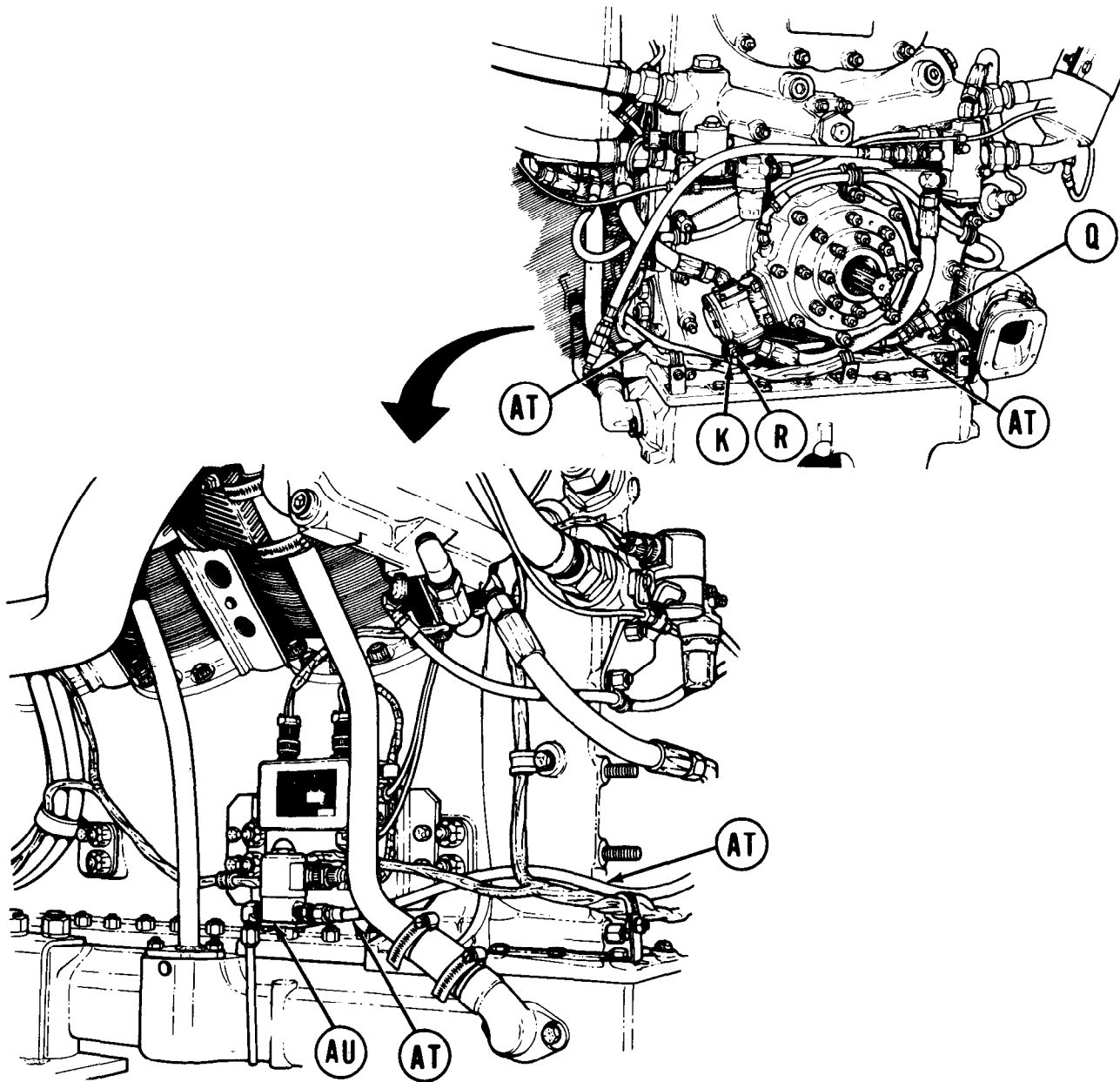

35. Using 9/16 open end wrench, connect 45-degree connector of hose assembly (AT) to leg of tee-cock assembly (Q).
36. Route hose assembly (AT) around side of engine to solenoid (AU). Connect straight connector of hose (AT) to solenoid (AU).
37. Place clamp (K) around hose (AT).
38. Using 5/8 inch socket, secure clamp (K) and hose (AT) to engine housing stud with washer and nut (R).

Go on to Sheet 11

TA108258

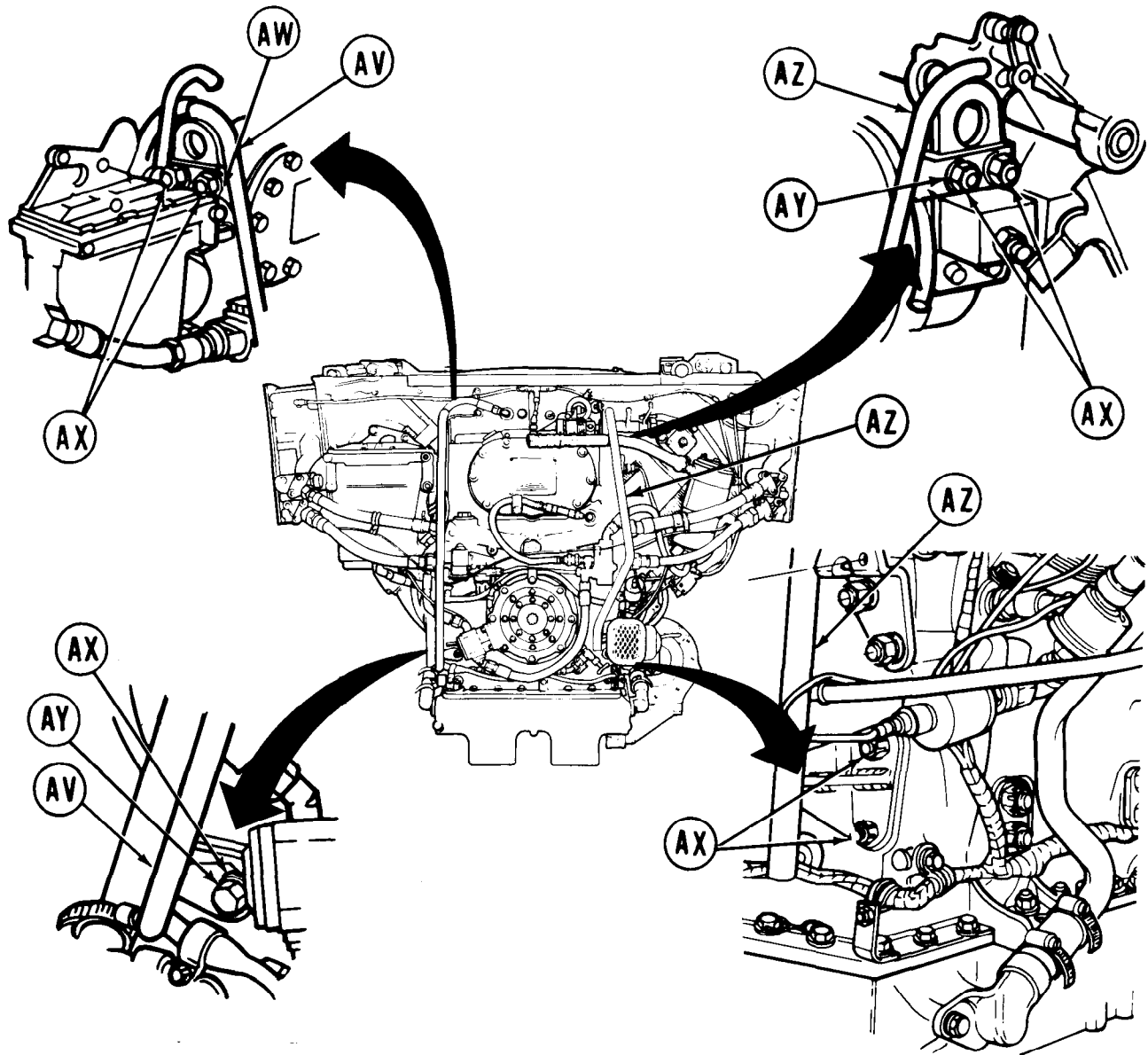
ENGINE REPLACEMENT**Power Takeoff Installation On Replacement Engine (Sheet 11 of 11)**

39. Place left guide (AV) in position on engine.
40. Place harness clamps (AW) in position.
41. Using 9/16 inch open end wrench, secure left guide (AV) to engine with three nuts (AX) and washers (AY).
42. Place right guide (AZ) in position on engine.
43. Using 9/16 inch socket, secure right guide (AZ) to engine with four nuts (AX) and washers (AY).

End of Task

TA108259

ENGINE REPLACEMENT

Accessory Drive Installation On Unserviceable Engine (Sheet 1 of 7)

NOTE

Replacement engines are received without the power takeoff unit installed. The power takeoff parts on the unserviceable engine must be exchanged with the accessory drive parts of the replacement engine.

TOOLS: 7/16 in. socket with 1/2 in. drive
Ratchet with 1/2 in. drive
9/16 in. socket with 1/2 in. drive
5/8 in. socket with 1/2 in. drive (2 required)
13/16 in. socket with 1/2 in. drive
8 in. socket extension with 1/2 in. drive
9/16 in. combination box and open end wrench
5/8 in. combination box and open end wrench (2 required)
7/8 in. combination box and open end wrench
13/16 in. combination box and open end wrench
5/16 in. allen wrench
11/16 in. socket wrench with 1/2 in. drive
Stud remover/installer

SUPPLIES: Accessory drive and attaching parts - retained from replacement engine
Clean rags

REFERENCE: TM 5-5420-226-20

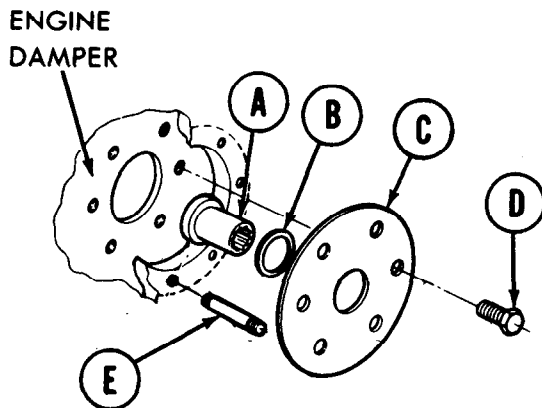

1. Install adapter ring (A), ring (B), and coupling (C) on engine damper.
2. Using 13/16 inch socket and extension, secure adapter assembly (C) with six bolts (D).
3. Using stud remover/installer, install eight studs (E) on engine housing.

Go on to Sheet 2

TA108260

ENGINE REPLACEMENT

Accessory Drive Installation On Unserviceable Engine (Sheet 2 of 7)

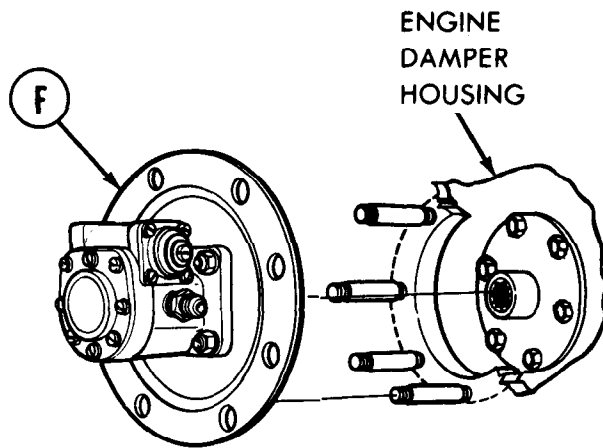

4. Install adapter (F) to engine damper housing.
5. Install bracket (G) to adapter (F) and secure with two washers (H) and two nuts (J).
6. Install remaining six washers (H) and nuts (J) securing adapter (F) to engine damper housing.
7. Using 5/8 inch socket, tighten eight nuts (J).

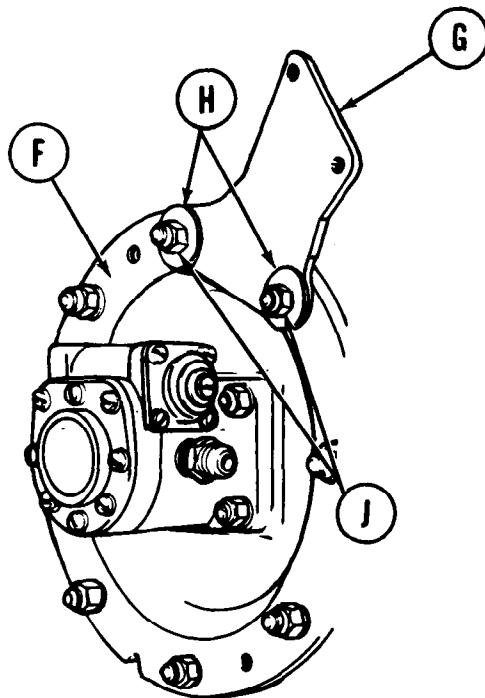

Go on to Sheet 3

TA108261

ENGINE REPLACEMENT

Accessory Drive Installation On Unserviceable Engine (Sheet 3 of 7)

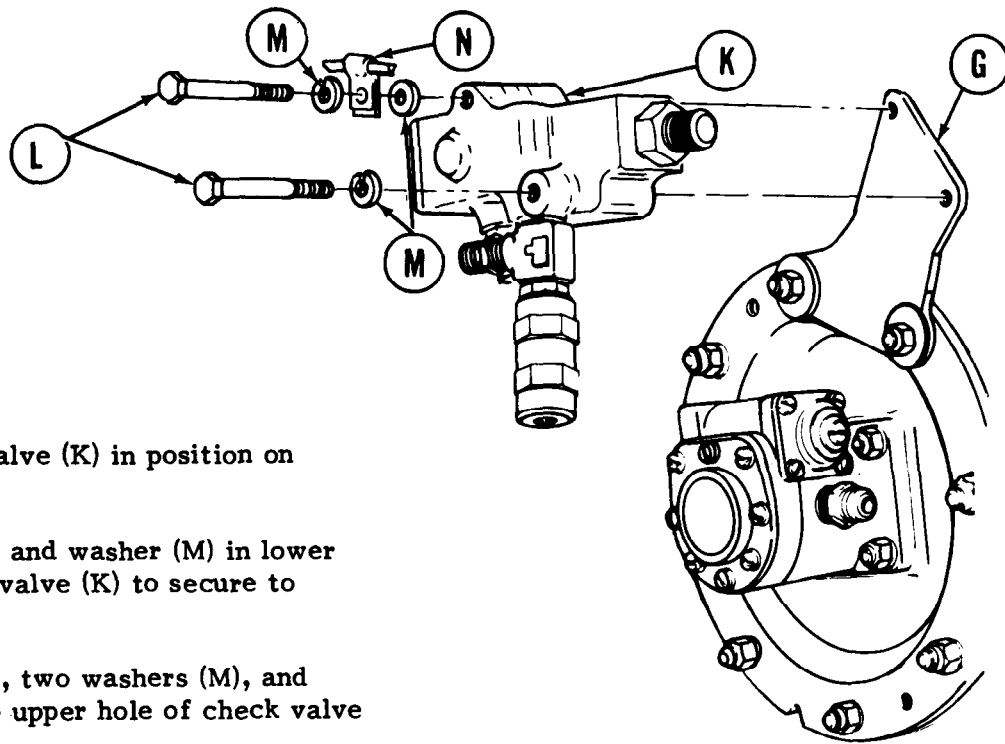

8. Place check valve (K) in position on bracket (G).
9. Install bolt (L) and washer (M) in lower hole of check valve (K) to secure to bracket (G).
10. Install bolt (L), two washers (M), and clamp (N) into upper hole of check valve (K).
11. Using 7/16 inch socket, tighten two bolts (L).
12. Using 7/8 inch open end wrench, install tube assembly (P) between fuel pump (Q) and fuel check valve (K).
13. Using 5/8 inch open end wrench, install tube assembly (R) between fuel filter (S) and tee (T) on check valve (K).

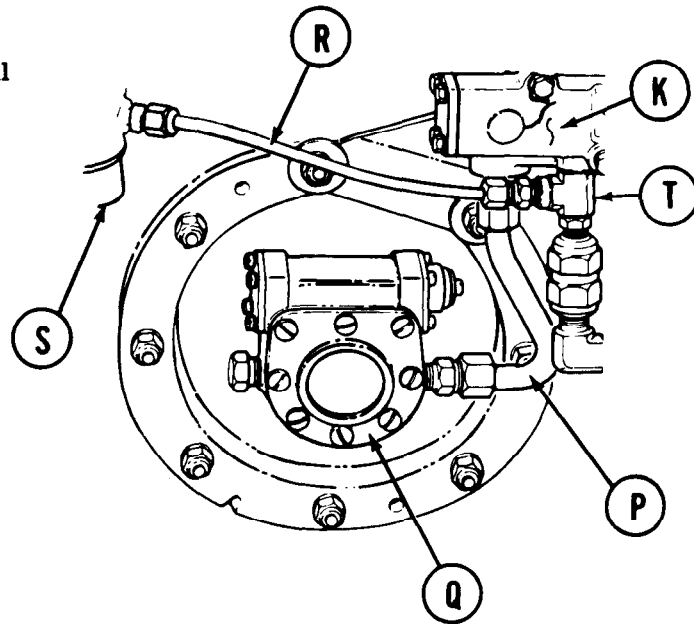

Go on to Sheet 4

TA108262

ENGINE REPLACEMENT**Accessory Drive Installation On Unserviceable Engine (Sheet 4 of 7)**

14. Using stud remover/installer, install stud (U).
15. Install bracket (V) with drain cock assembly (W).
16. Install nut (X) to secure bracket (V) to stud (U).
17. Using 9/16 inch wrench, tighten nut (X).

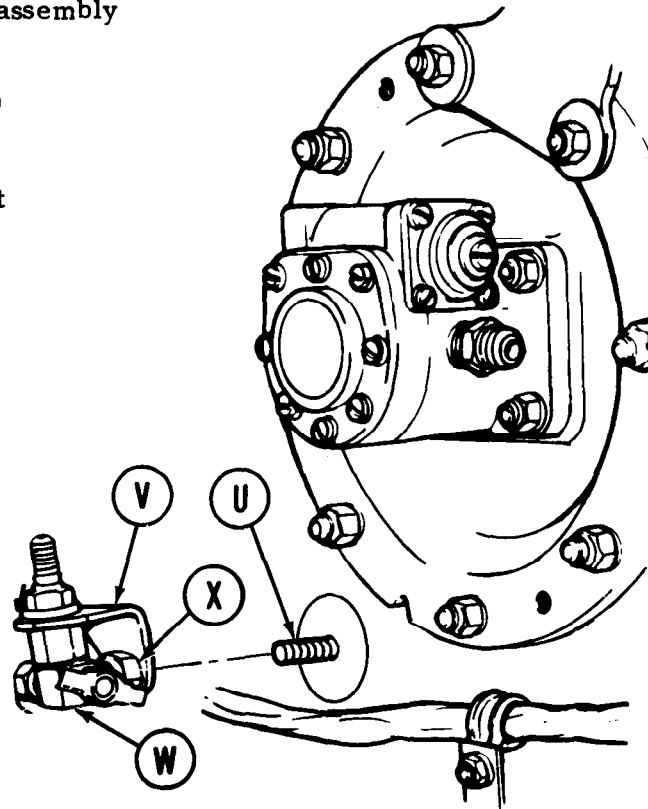

Go on to Sheet 5

TA108263

ENGINE REPLACEMENT

Accessory Drive Installation On Unserviceable Engine (Sheet 5 of 7)

18. Using 9/16 inch open end wrench, install hose assembly (Y) between drain cock (Z) and fuel-water separator valve (AA).
19. Using 9/16 inch open end wrench, install hose assembly (AB) between fuel-water separator (AC) and drain cock (Z).

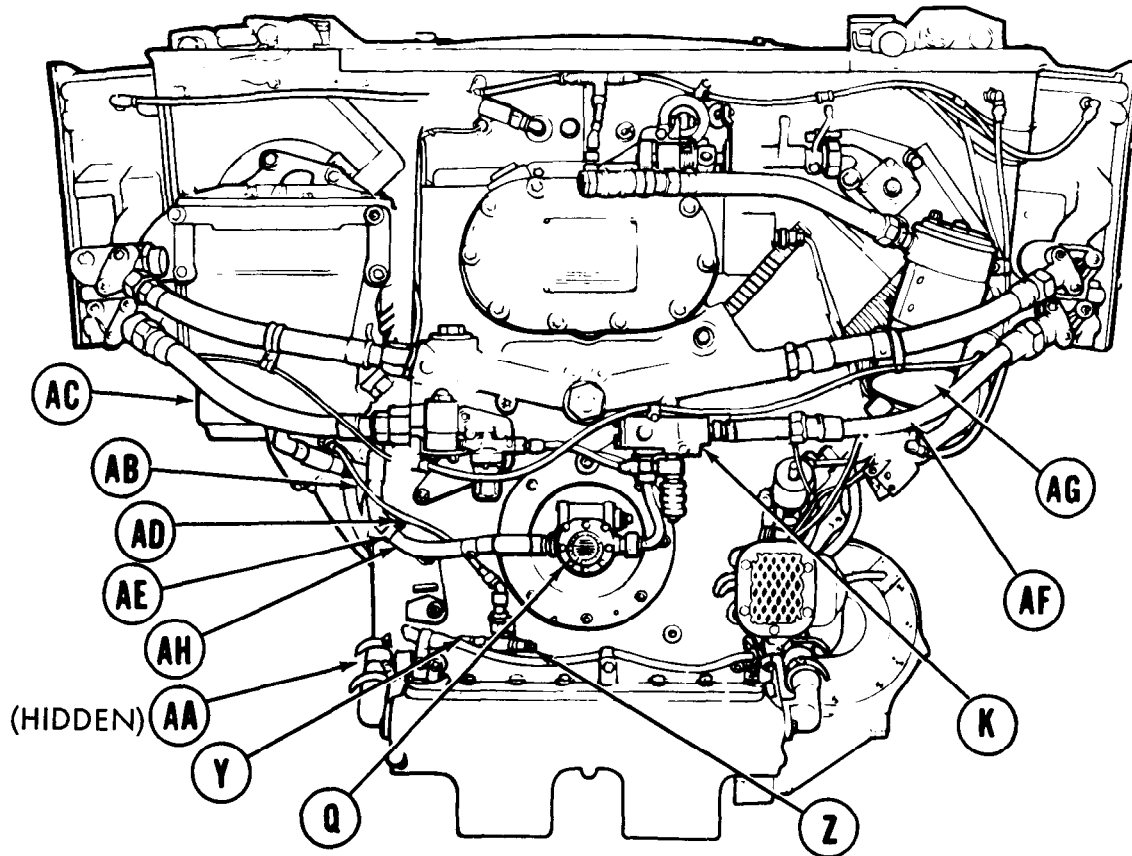

20. Using 9/16 inch open end wrench, install nut (AD) to secure clamp (AE) on hose assembly (AB) to engine.
21. Using 7/8 inch open end wrench and 3/4 inch open end wrench, install hose assembly (AF) between fuel check valve (K) and primary fuel filter (AG).
22. Using 7/8 inch open end wrench and 3/4 inch open end wrench, install hose assembly (AH) between fuel pump (Q) and fuel-water separator (AC).

Go on to Sheet 6

TA108264

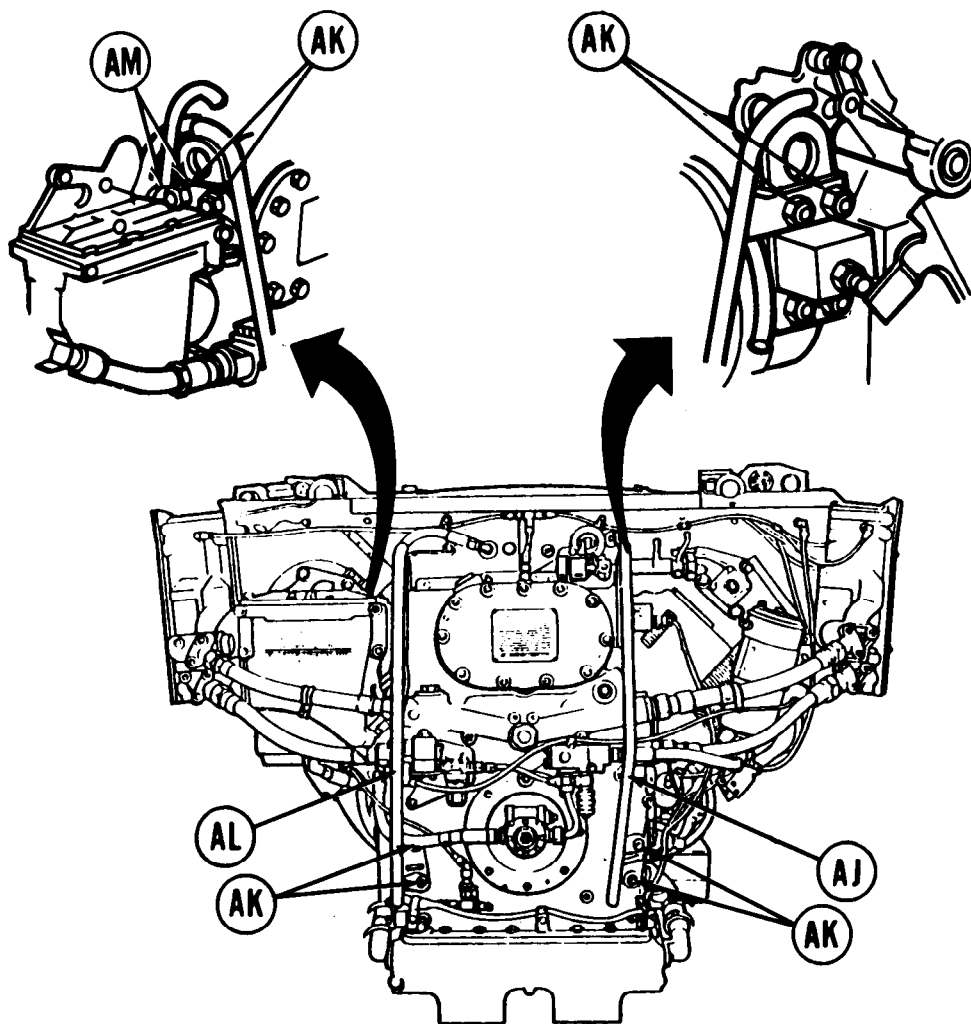
ENGINE REPLACEMENT**Accessory Drive Installation On Unserviceable Engine (Sheet 6 of 7)**

23. Place right guide (AJ) in position on engine.
24. Using 9/16 inch socket, install four nuts and washers (AK) securing guide (AJ) to engine.
25. Place left guide (AL) in position on engine.
26. Using 9/16 inch open end wrench, install clamps (AM) and four nuts and washers (AK) securing guide (AL) to engine.

Go on to Sheet 7

TA108265

ENGINE REPLACEMENT

Accessory Drive Installation On Unserviceable Engine (Sheet 7 of 7)

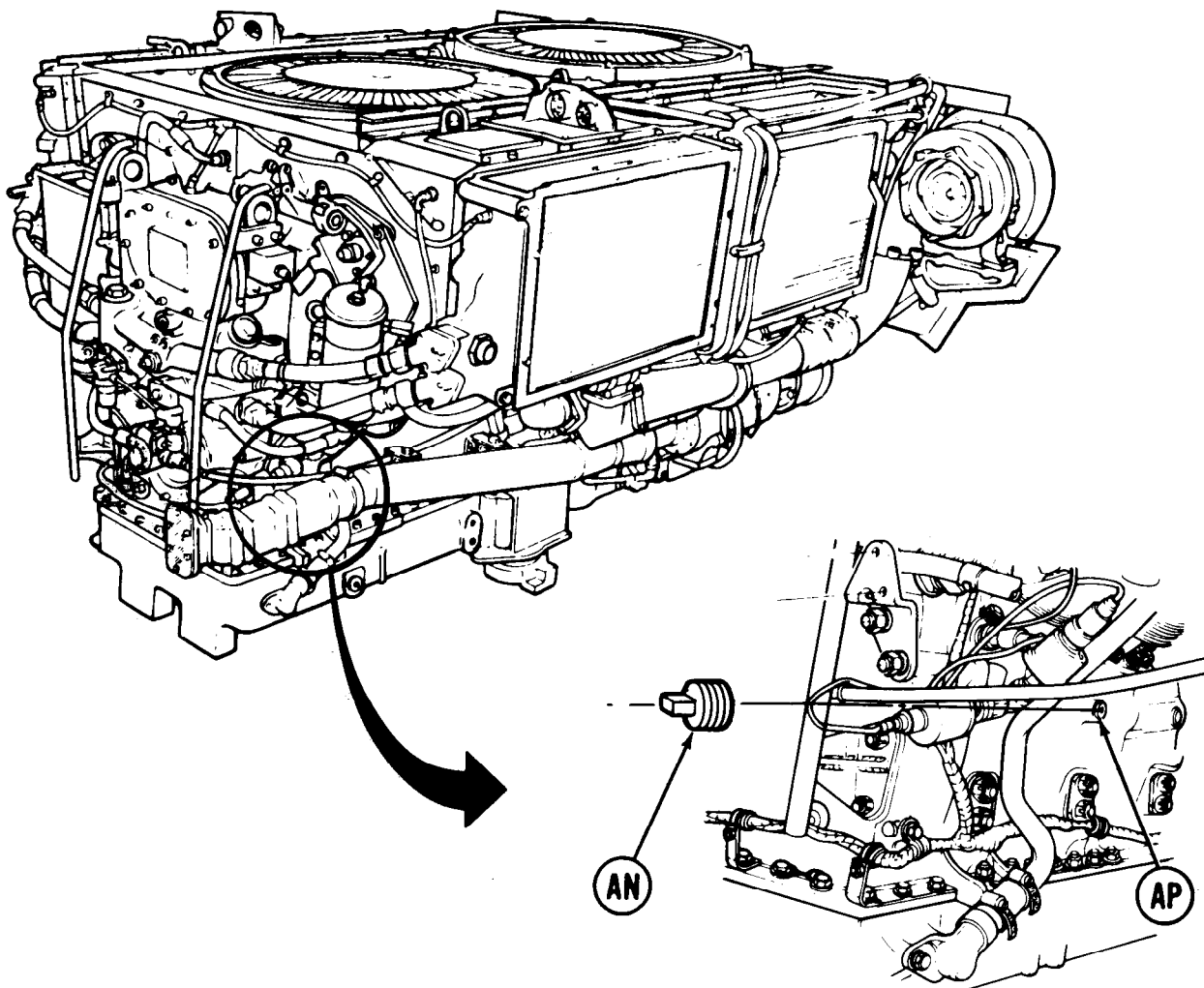

GENERATOR AIR INTAKE
REMOVED FOR CLARITY

27. Install plug (AN) in port (AP). If plug has socket head, use 5/16 inch socket head key. If plug has hexagon head, use 11/16 inch socket to install.

End of Task

TA108266

ENGINE REPLACEMENT
Replacement Engine Installation (Sheet 1 of 17)

PROCEDURE INDEX

PROCEDURE	PAGE
Removal (Unserviceable Engine)	3-53
Cleaning	3-60
Installation (Replacement Engine)	3-61

TOOLS:

Ratchet with 1/2 in. drive	1-3/16 in. open end wrench
7/16 in. combination box and open end wrench (2 required)	5/8 in. combination box and open end wrench
7/8 in. combination box and open end wrench	5/8 in. socket with 1/2 in. drive
1 in. combination box and open end wrench	5 in. extension with 1/2 in. drive
1-1/8 in. open end wrench	Flat-tip screwdriver
1-1/2 in. open end wrench	Spanner wrench
9/16 in. socket with 1/2 in. drive	Retaining ring pliers
1-1/8 in. socket with 1/2 in. drive	Torque wrench with 1/2 in. drive (0-175 lb-ft) (0-237 N•m)
1/2 in. combination box and open end wrench	3/4 in. combination box and open end wrench
1-5/8 in. open end wrench (5120-00-203-4802)	Hoist (5,000 pounds)

SPECIAL TOOLS: Pinion turning wrench (Item 5, Chapter 2, Section I)
 Engine and transmission sling (Item 1, Chapter 2, Section I)
 Lifting sling (Item 4, Chapter 2, Section I)
 Puller adapter (Item 2, Chapter 2, Section I)
 Slide hammer puller (Item 3, Chapter 2, Section I)

FABRICATED TOOLS: Wrench (Figure D-1, Appendix D)

SUPPLIES: Gasket
 Preformed packing
 Drain pan (suitable container)
 Gloves (Item 31, Appendix B)
 Rags (Item 35, Appendix B)
 Dry cleaning solvent (Item 12, Appendix B)
 Tags (Item 30, Appendix B)
 Lockwashers
 Goggles (Item 32, Appendix B)

REFERENCES: TM 5-5420-226-20
 LO 5-5420-226-12

PERSONNEL: Two

Go on to Sheet 2

ENGINE REPLACEMENT

Replacement Engine Installation (Sheet 2 of 17)

REMOVAL:

1. Using 1-1/8 inch wrench, loosen connection (A). Remove line (B) from engine.
2. Using hands, remove lead (C) from fuel solenoid (D).

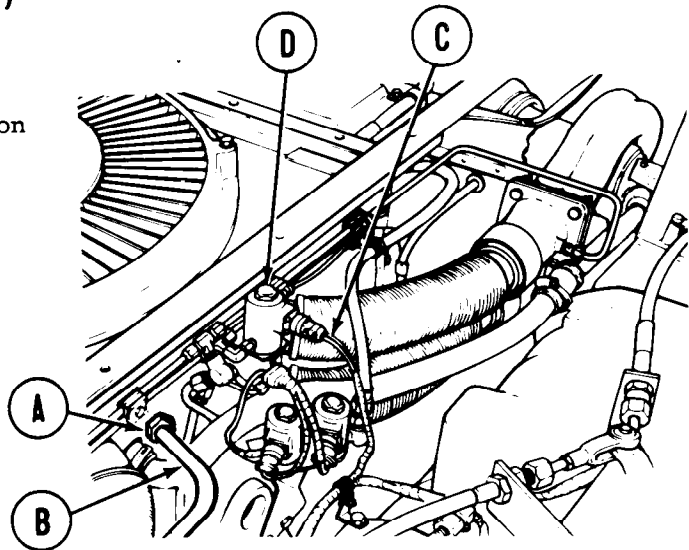

NOTE

Tag oil cooler tubes as they are removed for later installation. Removal of left and right side oil cooler tubes are the same.

NOTE

When removing the oil cooler tubes, remove the outer tube and its adapter before removing the inner tube and its adapter.

3. Using 1-5/8 inch open end wrench to hold adapter (E), use 1-1/2 inch wrench to remove nut (F) securing outer tube (G). Pull tube (G) towards transmission until it is free of adapter (E).
4. Using 1-5/8 inch wrench, remove outer adapter (E) and washer (H) from oil cooler (J).
5. Perform steps 3 and 4 to remove inner oil cooler tube (K), inner adapter (E), and washer (H).

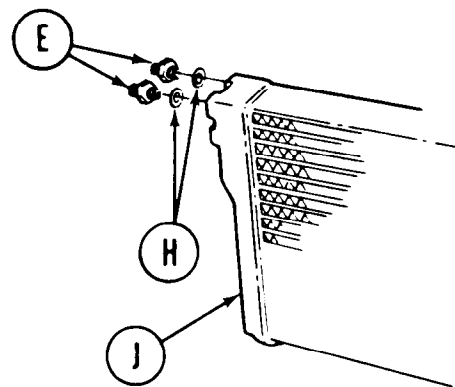
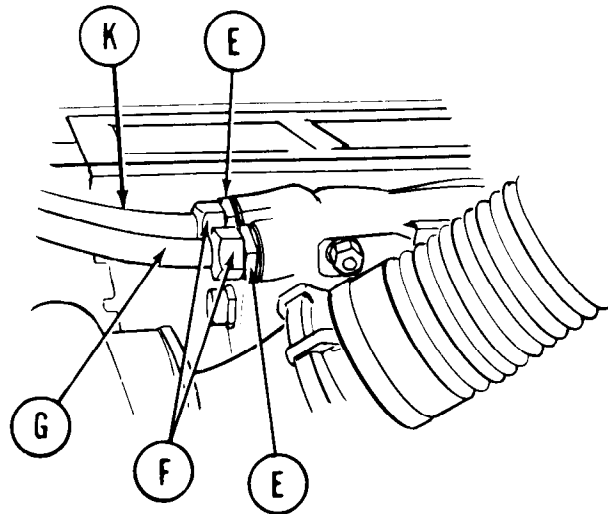

Go on to Sheet 3

TA108268

ENGINE REPLACEMENT

Replacement Engine Installation (Sheet 3 of 17)

6. Using 1-5/8 inch wrench to hold adapters (L), use 1-1/2 inch wrench to remove two nuts (M) from two adapters (L).
7. Remove oil cooler tube assemblies (G) and (K).

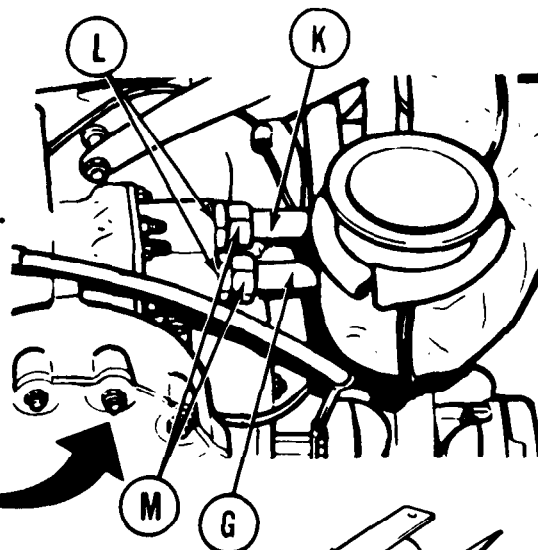
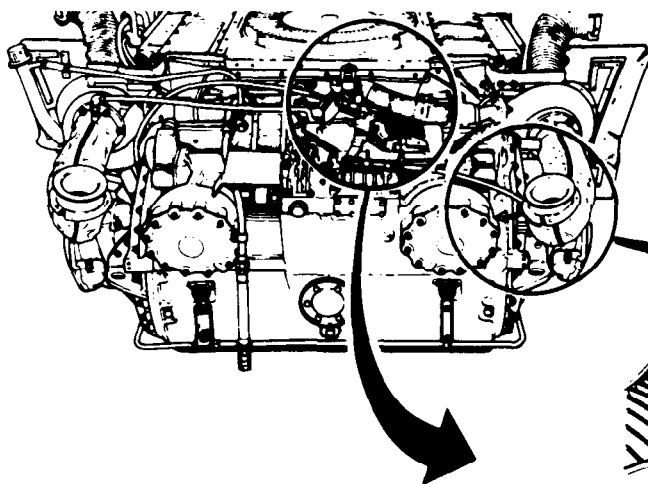

8. Using screwdriver, remove clamps (N) and (P).
9. Remove engine breather tube (Q) from powerplant.
10. Using 1 inch wrench, remove tachometer adapter (R) from engine.
11. Using 7/16 inch wrench to hold screw (S), use 7/16 inch wrench to remove nut (T). Remove linkage (U) from accelerator cross shaft (V).
12. Use procedure described in step 11 and remove linkage (W).

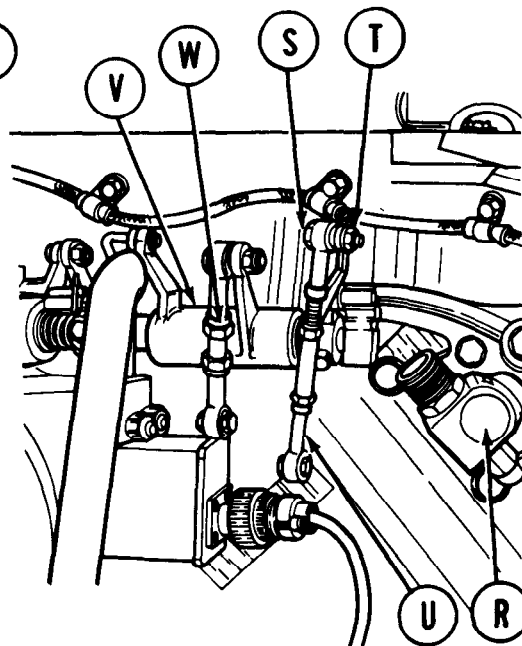
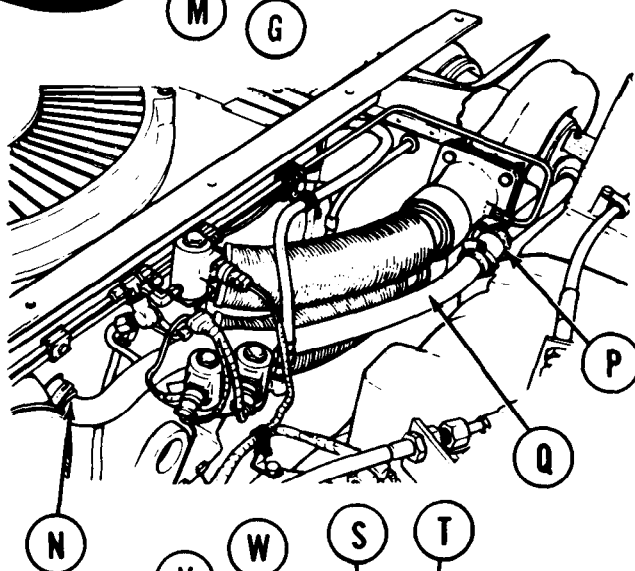

FRONT OF ENGINE

Go on to Sheet 4

TA108269

ENGINE REPLACEMENT

Replacement Engine Installation (Sheet 4 of 17)

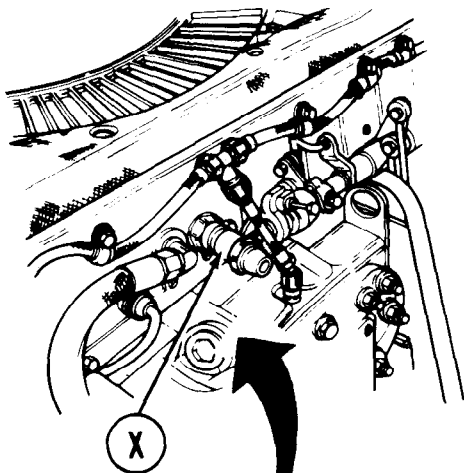

13. Using 1 inch wrench, remove fire extinguisher adapter (X).
14. Using 1-1/8 inch wrench to hold fitting (Y), use 1-3/16 inch wrench and remove coupling (Z).
15. Using 1-1/8 inch wrench, remove fitting (Y).

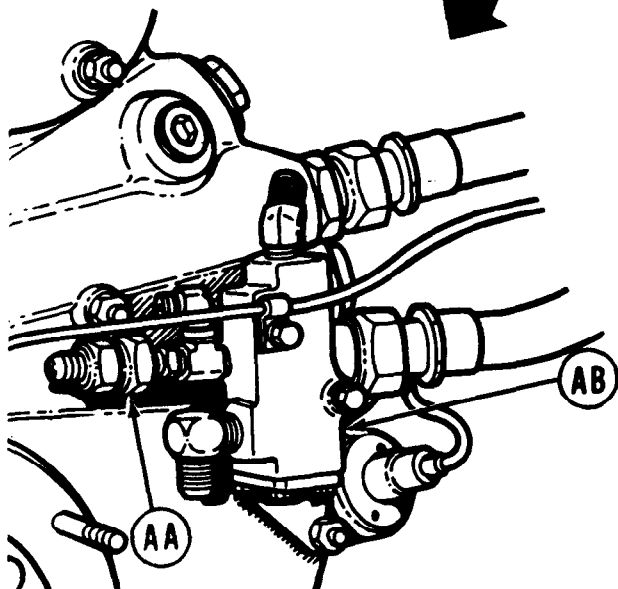
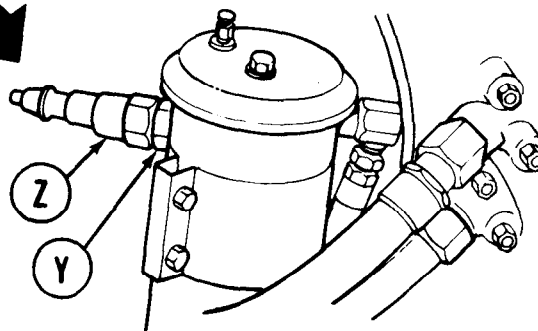
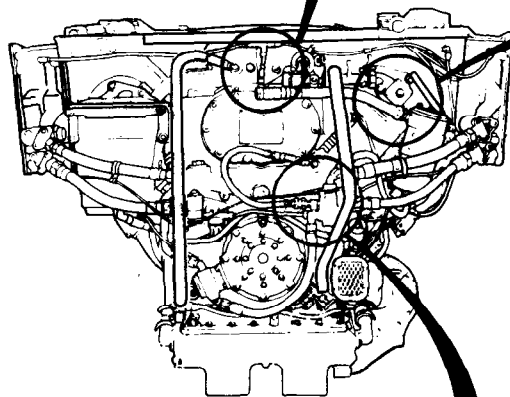

16. Using 3/4 inch wrench, remove quick-disconnect coupling (AA) from fuel check valve (AB).

Go on to Sheet 5

TA108270

ENGINE REPLACEMENT

Replacement Engine Installation (Sheet 5 of 17)

NOTE

Tag air cleaner hoses as they are removed for later installation.

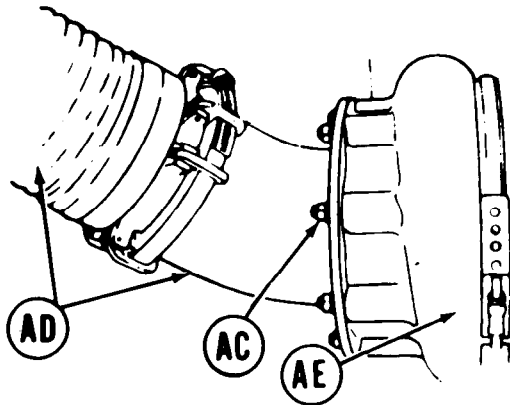

17. Using 1/2 inch wrench, remove eight nuts, washers, and lockwashers (AC). Remove left air cleaner hose and elbow assembly (AD) from turbocharger (AE).
18. Using procedure described in step 17, remove right air cleaner hose and elbow assembly.

NOTE

- Cover all openings to prevent the entrance of foreign material.
 - Perform steps 19, 20, and 21 only if you are replacing a 2D engine.
 - Remove left and right exhaust ejector tubes (TM 5-5420-226-20-2) if replacing a 2DA engine.
19. Using 7/8 inch wrench, loosen connecting nut (AF) and connecting nut (AG). Remove transmission vent line (AH) from transmission.

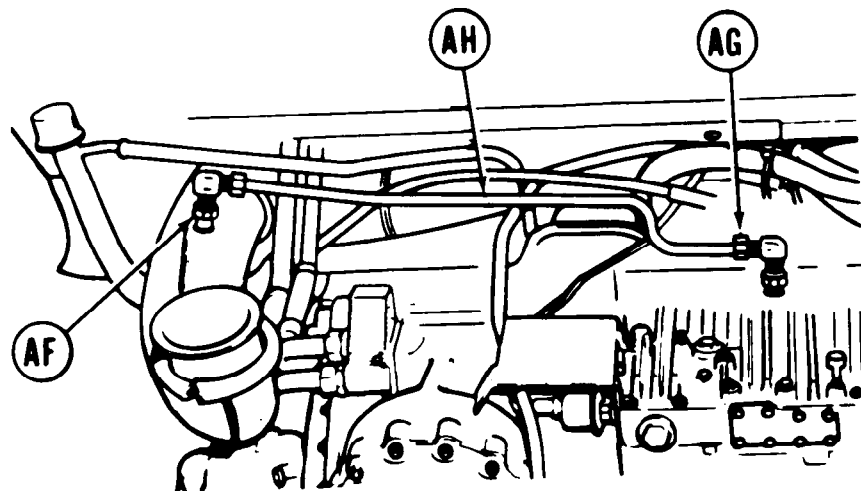

Go on to Sheet 6

ENGINE REPLACEMENT

Replacement Engine Installation (Sheet 6 of 17)

20. Using 9/16 inch socket and 5 inch extension, remove six nuts (AJ) from right exhaust pipe flange (AK). Remove exhaust pipe (AL) and gasket (AM) from turbocharger.
21. Using procedures described in step 20, remove left exhaust pipe.

NOTE

Cover all openings to prevent the entrance of foreign material.

22. Using spanner wrench, disconnect cannon plug (AN).
23. Using hands, feed wiring harness (AP) through grommet (AQ) until cannon plug (AN) is flush with grommet (AQ).
24. Remove engine wiring harness (TM 5-5420-226-20).

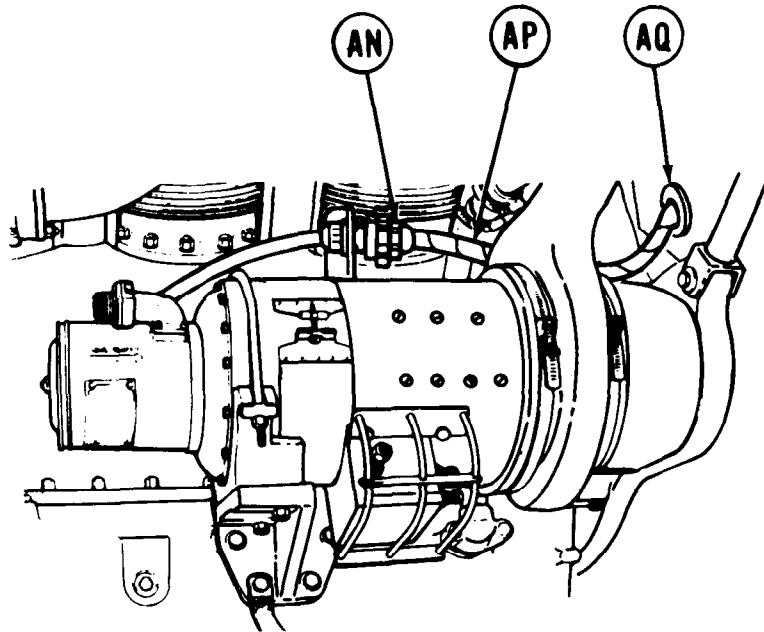
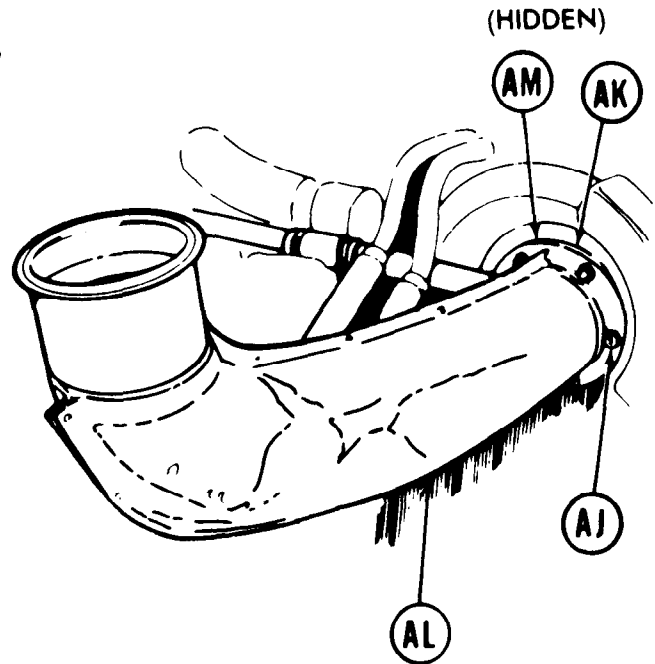

Go on to Sheet 7

TA108272

ENGINE REPLACEMENT**Replacement Engine Installation (Sheet 7 of 17)**

25. Using 1-1/8 inch wrench, remove input shaft plug (AR) and gasket (AS) from transmission.

CAUTION

It may be necessary to place finger through retaining ring (AT) to make sure that it does not fall into transmission housing during removal.

26. Using retaining ring pliers, remove retaining ring (AT) at rear of input shaft (AU).
27. Using puller (Item 3, Chapter 2, Section I) and adapter (Item 2, Chapter 2, Section I), draw the input shaft (AU) rearward until it is disengaged from the engine drive connection.

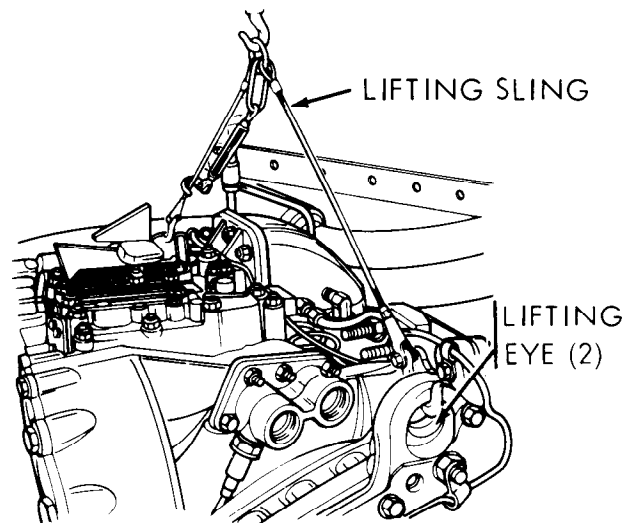
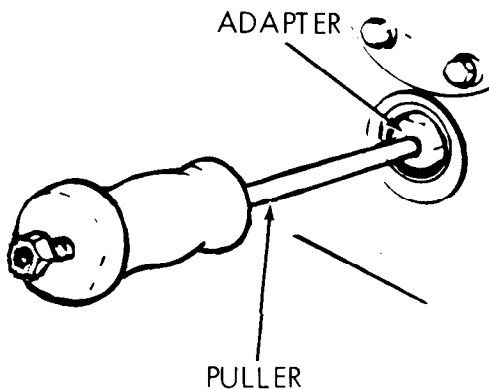
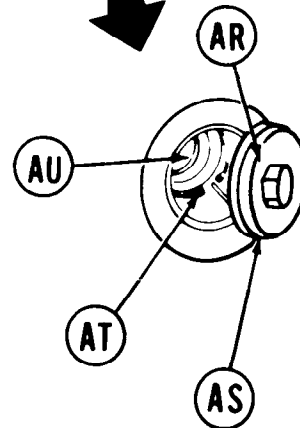
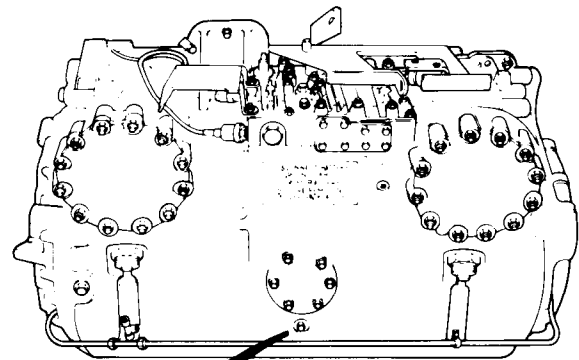

28. Attach lifting sling (Item 4, Chapter 2, Section I) to transmission lifting eyes. Using a suitable hoist, take up slack until sling supports weight of transmission without lifting powerplant from blocks.
29. Place a pan under engine and transmission at separation point to catch oil.

Go on to Sheet 8

TA108273

ENGINE REPLACEMENT

Replacement Engine Installation (Sheet 8 of 17)

30. Using fabricated wrench and 5/8 inch socket, remove screw (AV), nut (AW), and washer (AX) from left and right side of transmission.
31. Using fabricated wrench or 5/8 inch wrench, remove 17 screws (AY), lockwashers (AZ), and washers (BA) that secure transmission to engine.
32. Carefully move transmission rearward to separate from engine.
33. Using hands, grasp wiring harness (AP) and carefully pull towards transmission until grommet (AQ) and cannon plug (AN) are free of shroud.

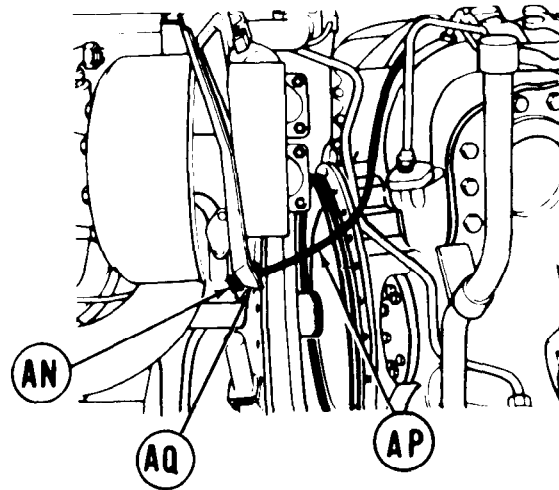
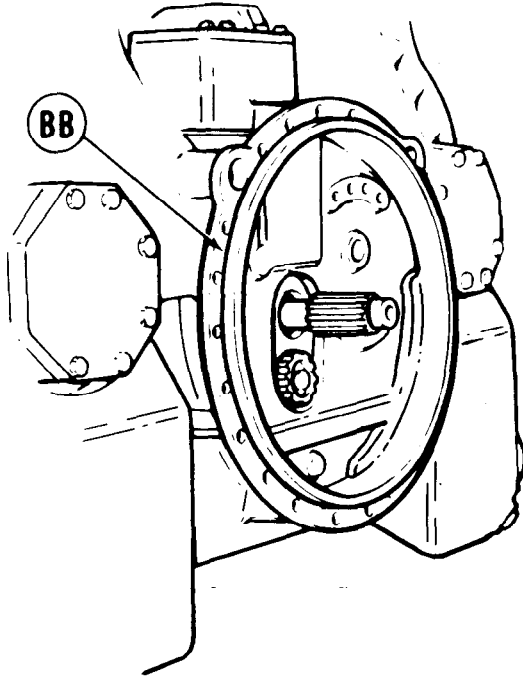
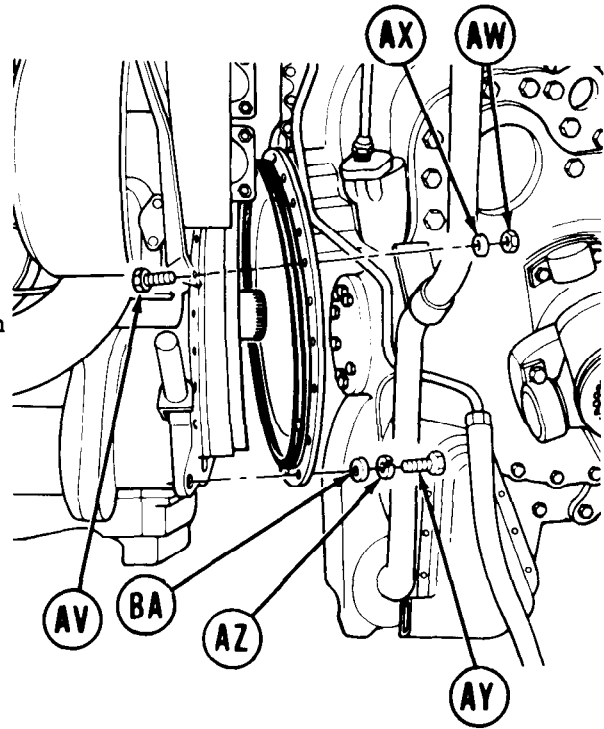

34. Remove transmission to engine preformed packing (BB) and throw packing away.

■ Go on to Sheet 8.1

ENGINE REPLACEMENT

Replacement Engine Installation (Sheet 8.1 of 17)

CLEANING:**WARNING**

Dry cleaning solvent P-D-680 is toxic and flammable. To avoid injury, wear protective goggles and gloves and use in a well-ventilated area. Avoid contact with skin, eyes, and clothes, and do not breathe vapors. Do not use near open fire or excessive heat. The flash point for Type I dry cleaning solvent is 100°F (38°C) and for Type II is 140°F (60°C). If you become dizzy while using dry cleaning solvent, get fresh air immediately and get medical aid. If contact with eyes is made, wash your eyes with water and get medical aid immediately.

Wearing rubber gloves, clean all parts that have been removed from transmission and engine with dry cleaning solvent. Wipe dry with clean, lint-free rags.



ENGINE REPLACEMENT**Replacement Engine Installation (Sheet 9 of 17)****INSTALLATION:**

1. Remove shipping caps, plugs, covers, and mounts from replacement engine as components are installed and install them on unserviceable engine.

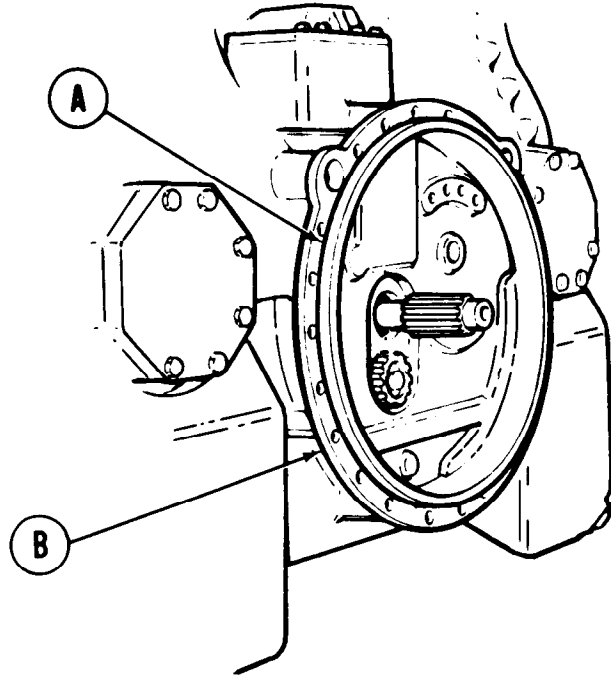

2. Position new preformed packing (A) on transmission mounting flange (B).

3. Using hands, feed cannon plug (C) through shroud and secure grommet (D) to shroud.

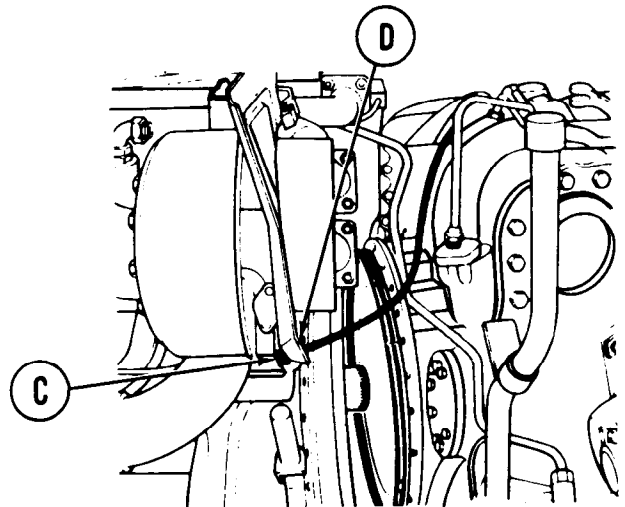

Go on to Sheet 10

TA108275

ENGINE REPLACEMENT

Replacement Engine Installation (Sheet 10 of 17)

4. Using transmission sling (Item 4, Chapter 2, Section I) and a suitable hoist (transmission weighs approximately 3,000 pounds), align transmission dowel pins with engine and carefully advance transmission until transmission mounting flange is in contact with engine transmission adapter.
5. Using fabricated wrench (Item 1, Appendix D) and 5/8 inch socket, install and tighten screw (E), washer (F), and nut (G) on left and right side of transmission/engine.
6. Using fabricated wrench or 5/8 inch wrench, install and tighten 17 screws (H), lockwashers (J), and flat washers (K) securing transmission to engine flange.
7. Remove transmission sling from transmission.

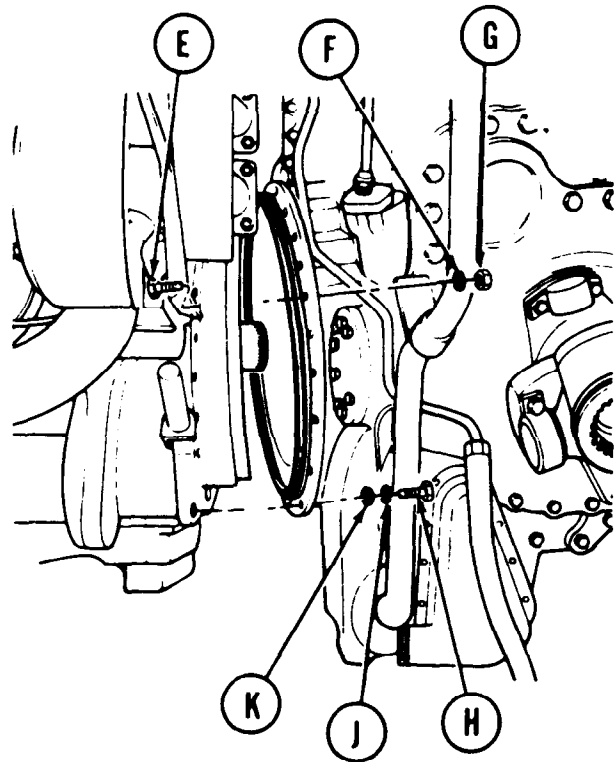
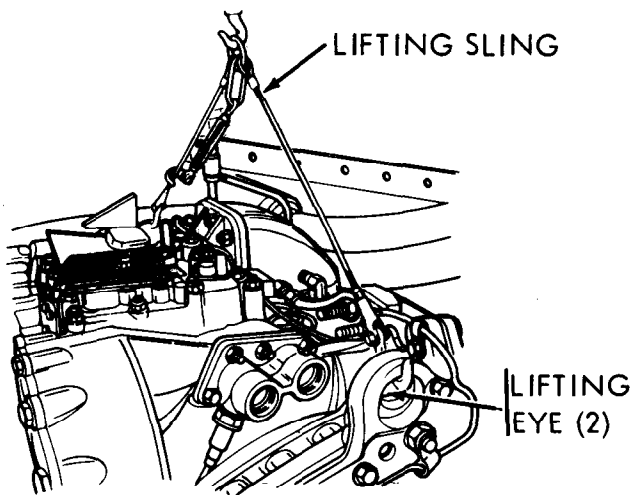

Go on to Sheet 11

TA108276

ENGINE REPLACEMENT

Replacement Engine Installation (Sheet 11 of 17)

8. Push transmission input shaft (L) into transmission. If engine and transmission splines do not align, use 5/8 inch socket to remove six power takeoff cover screws (M) and lockwashers (N). Remove cover (P) and gasket (Q). Throw gasket (Q) away.

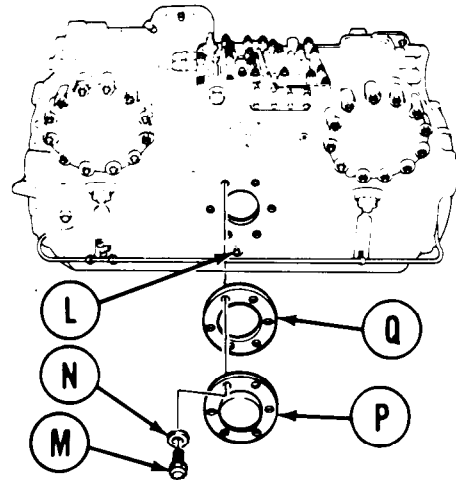

PINION
TURNING
WRENCH

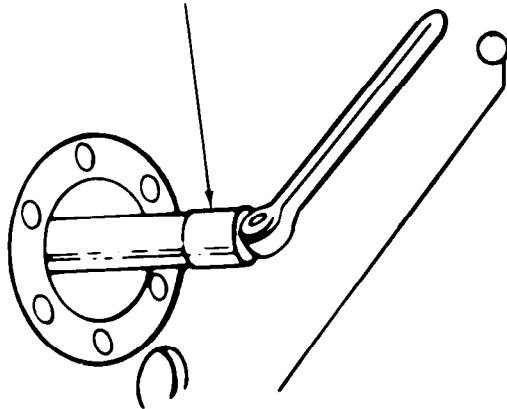

9. Using pinion turning wrench, turn transmission until splines align and shaft (L) will slide in and seat properly.
10. Remove pinion turning wrench.
11. Using retaining ring pliers, install retaining ring (R) on input shaft (L).
12. Position gasket (S) onto plug (T), and using 1-1/8 inch socket and torque wrench, tighten plug (T) to 50-60 lb-ft (68-81 N•m).

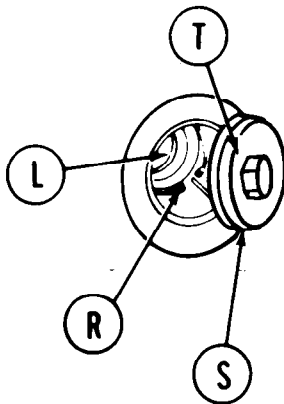

13. Position new power takeoff gasket (Q) and cover (P) on transmission housing and using 5/8 inch socket, install six screws (M) and washers (N).

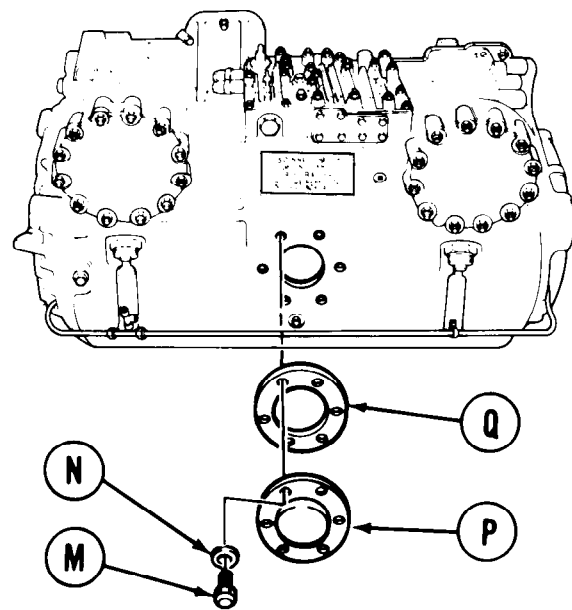

Go on to Sheet 12

ENGINE REPLACEMENT

Replacement Engine Installation (Sheet 12 of 17)

14. Position linkage (U) (long piece) onto cross shaft (V), and using 7/16 inch wrench to hold nut (W), use 7/16 inch wrench to install screw (X) through linkage (U).
15. Position linkage (Y) (short piece) onto cross shaft (V), and using 7/16 inch wrench to hold nut (Z), use 7/16 inch open end wrench and install screw (AA) through linkage (Y).

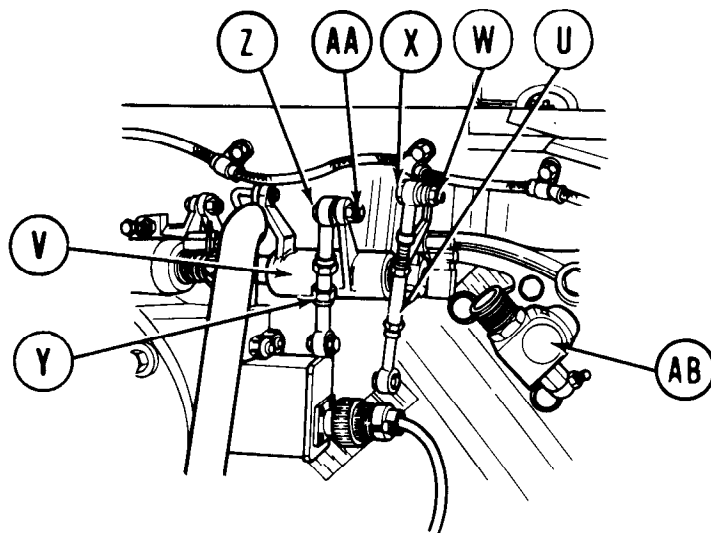

16. Using 1 inch wrench, install tachometer adapter (AB).
17. Using 3/4 inch wrench, connect quick-disconnect coupling (AC) to fuel check valve (AD).

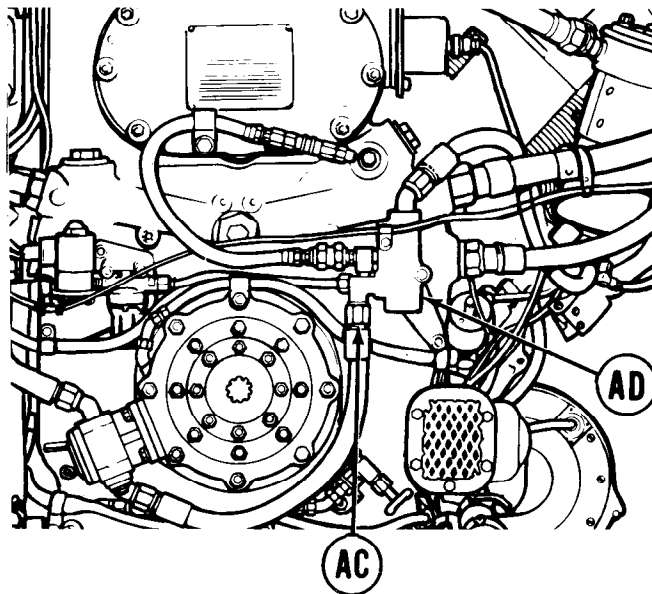

Go on to Sheet 13

TA108278

ENGINE REPLACEMENT**Replacement Engine Installation (Sheet 13 of 17)**

18. Using 1-1/8 inch wrench, install fitting (AE).
19. Using 1-3/16 inch wrench, install coupling (AF) to fitting (AE).

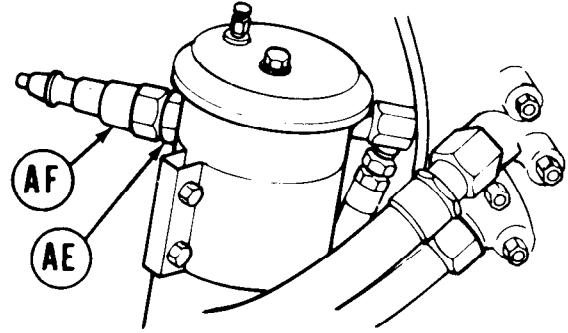
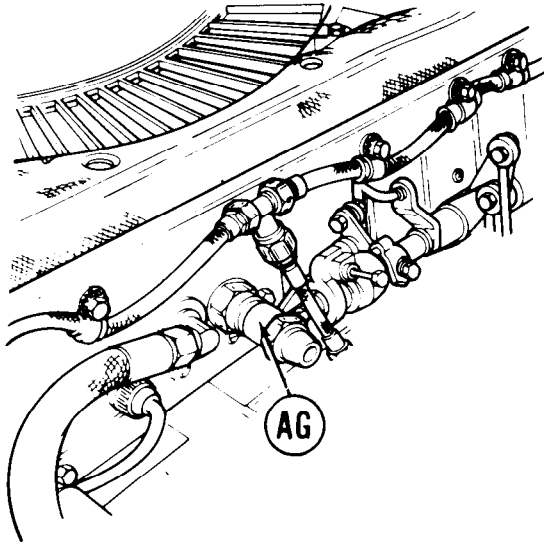

20. Using 1 inch wrench, install fire extinguisher adapter (AG).
21. Install engine wiring harness (TM 5-5420-226-20).

Go on to Sheet 14

TA108279

ENGINE REPLACEMENT

Replacement Engine Installation (Sheet 14 of 17)

- 22. Position left air cleaner hose and elbow assembly (AH) onto turbocharger (AJ), and using 1/2 inch wrench, install eight flat washers, lockwashers, and nuts (AK) securing air cleaner hose and elbow assembly to turbocharger.
- 23. Using procedure described in step 22, install right air cleaner hose and elbow assembly.

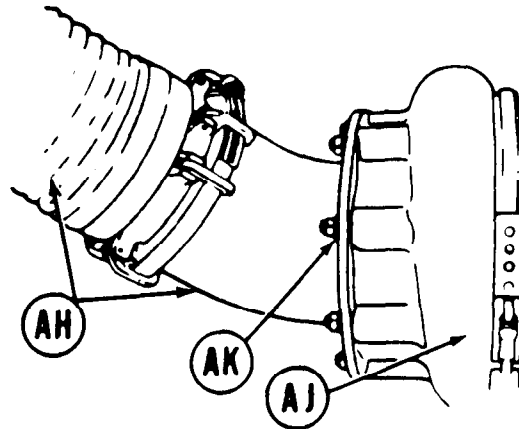

NOTE

Perform steps 24, 25, and 26 only if you are replacing a 2D engine.

- 24. Position exhaust pipe gasket (AL) and right exhaust pipe (AM) onto exhaust flange (AN) and, using 9/16 inch socket and extension, install six nuts (AP).
- 25. Using procedure described in step 24, install left exhaust pipe.
- 26. Position transmission vent line (AQ) onto transmission, and using 7/8 inch wrench, secure line (AQ) by tightening connecting nut (AR) and connecting nut (AS).

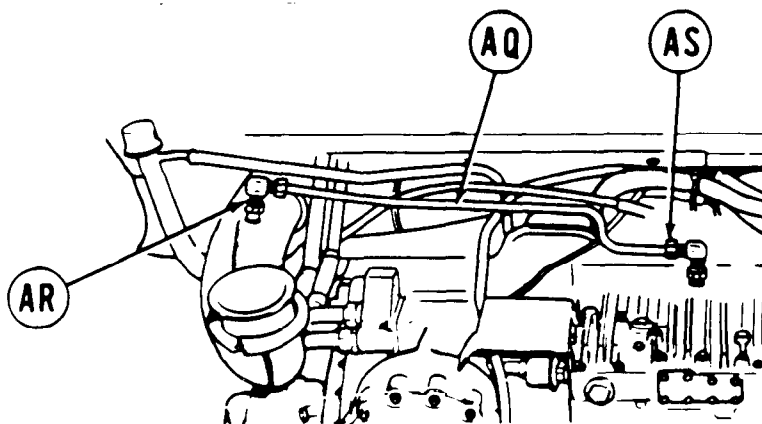
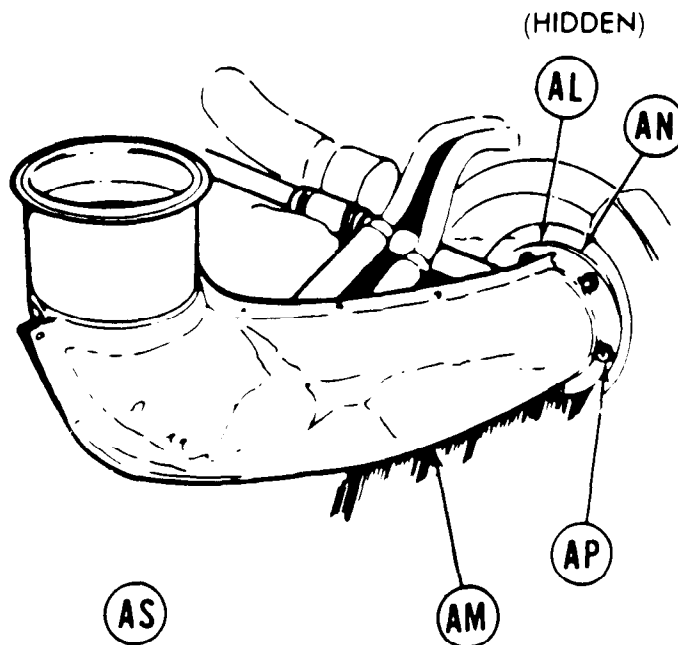

Go on to Sheet 15

ENGINE REPLACEMENT

Replacement Engine Installation (Sheet 15 of 17)

- 27. Position engine breather tube (AT) and clamps (AU) and (AV) onto engine.
- 28. Using screwdriver, tighten two screws securing clamps (AU) and (AV).

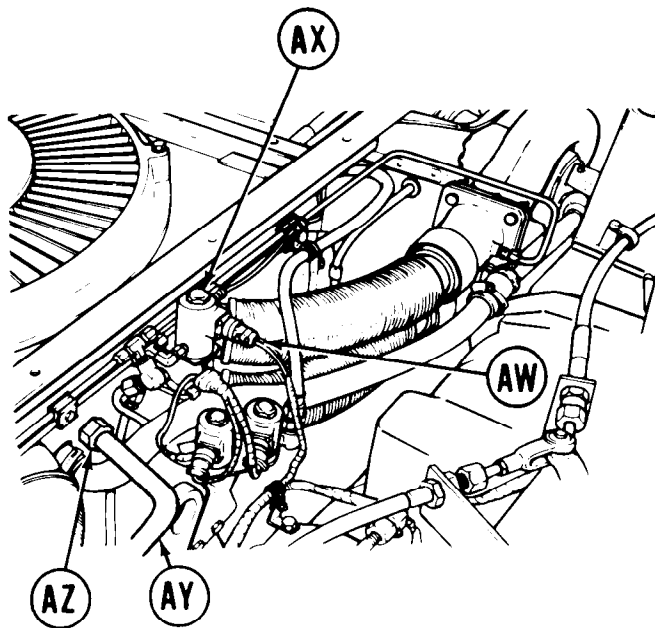
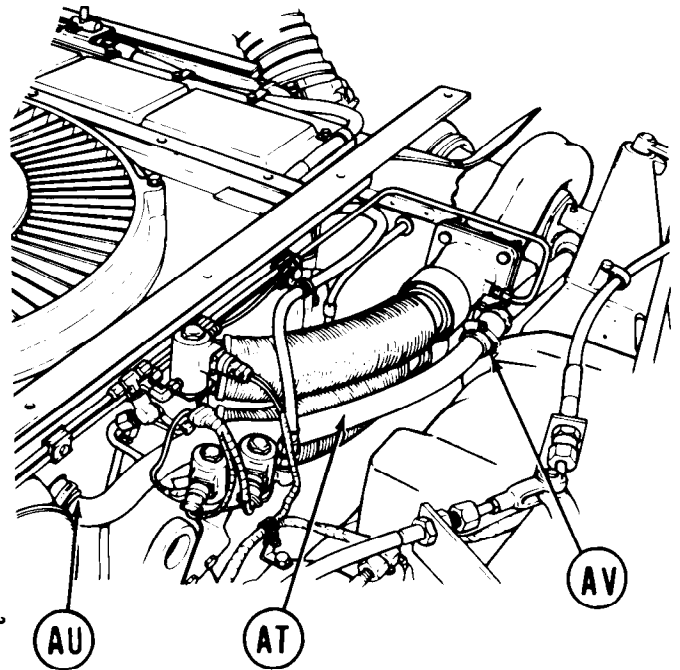

- 29. Connect electrical lead (AW) to solenoid (AX).
- 30. Position fuel return line (AY) onto connection on engine, and using 1-1/8 inch wrench, tighten connector (AZ).

- 31. Using hands, position cannon plug (C) from grommet (D) to connector.
- 32. Using spanner wrench, install cannon plug (C) to connector (BA).

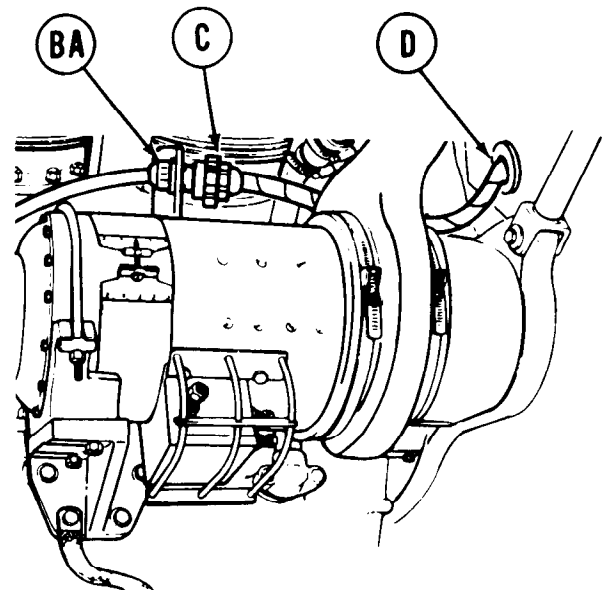

Go on to Sheet 16

TA108281

ENGINE REPLACEMENT

Replacement Engine Installation (Sheet 16 of 17)

33. Using 1-5/8 inch wrench, install inner washer (BB) and adapter (BC) to oil cooler (BD) on right side of engine.

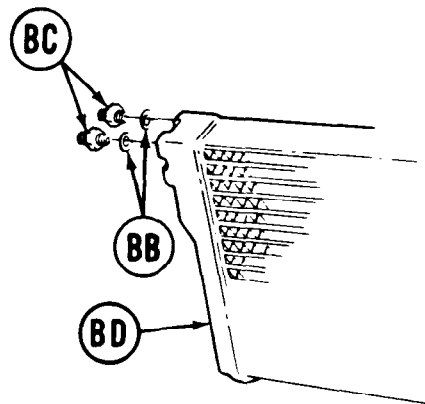
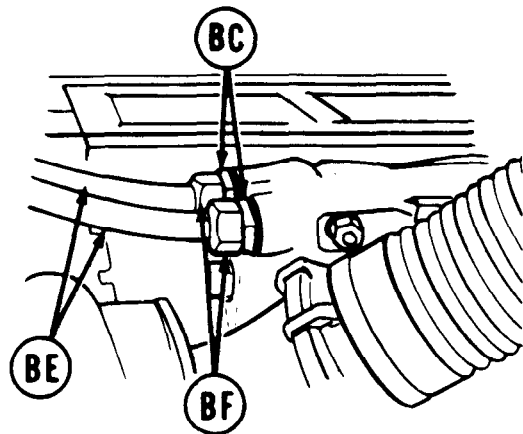

34. Position inner oil cooler tube (BE) to inner adapter (BC), and using 1-1/2 inch wrench, tighten nut (BF) to adapter (BC).
35. Perform steps 33 and 34 for the outer oil cooler tube (BE) and outer adapter (BC).
36. Position inner oil cooler tube (BE) onto inner adapter (BG). Using 1-1/2 inch wrench, tighten nut (BF) to inner adapter (BG).
37. Perform step 36 for the outer oil cooler tube (BE).
38. Using procedures described in steps 33 thru 37, install the oil cooler tubes to the left side of the engine.
- 38.1 Install left and right exhaust ejector tube (TM 5-5420-226-20-2) if replacing a ZDA engine.

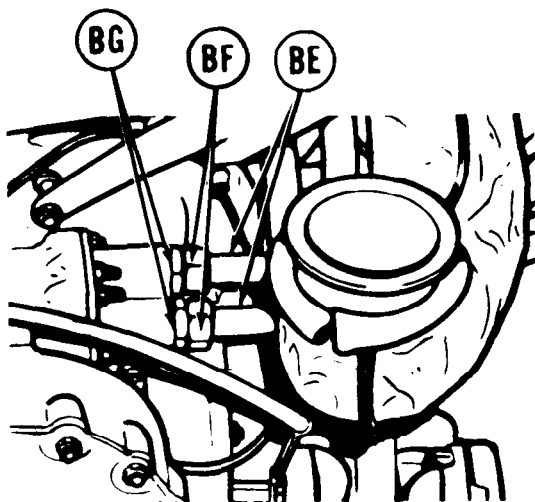

Go on to Sheet 17

ENGINE REPLACEMENT**Replacement Engine Installation (Sheet 17 of 17)**

39. Install engine mounts (TM 5-5420-226-20).
40. Install engine shroud and supports (TM 5-5420-226-20).
41. Install shifting linkage and brackets (TM 5-5420-226-20).
42. Install steering linkage and brackets (TM 5-5420-226-20).
43. Check engine oil for proper level. Drain or fill if necessary (LO 5-5420-226-12).
44. Check transmission oil for proper level. Drain or fill if necessary (LO 5-5420-226-12).
45. Test run engine using powerplant test (ground hop) kit (TM 5-5420-226-20).
46. Install powerplant (TM 5-5420-226-20).

End of Task

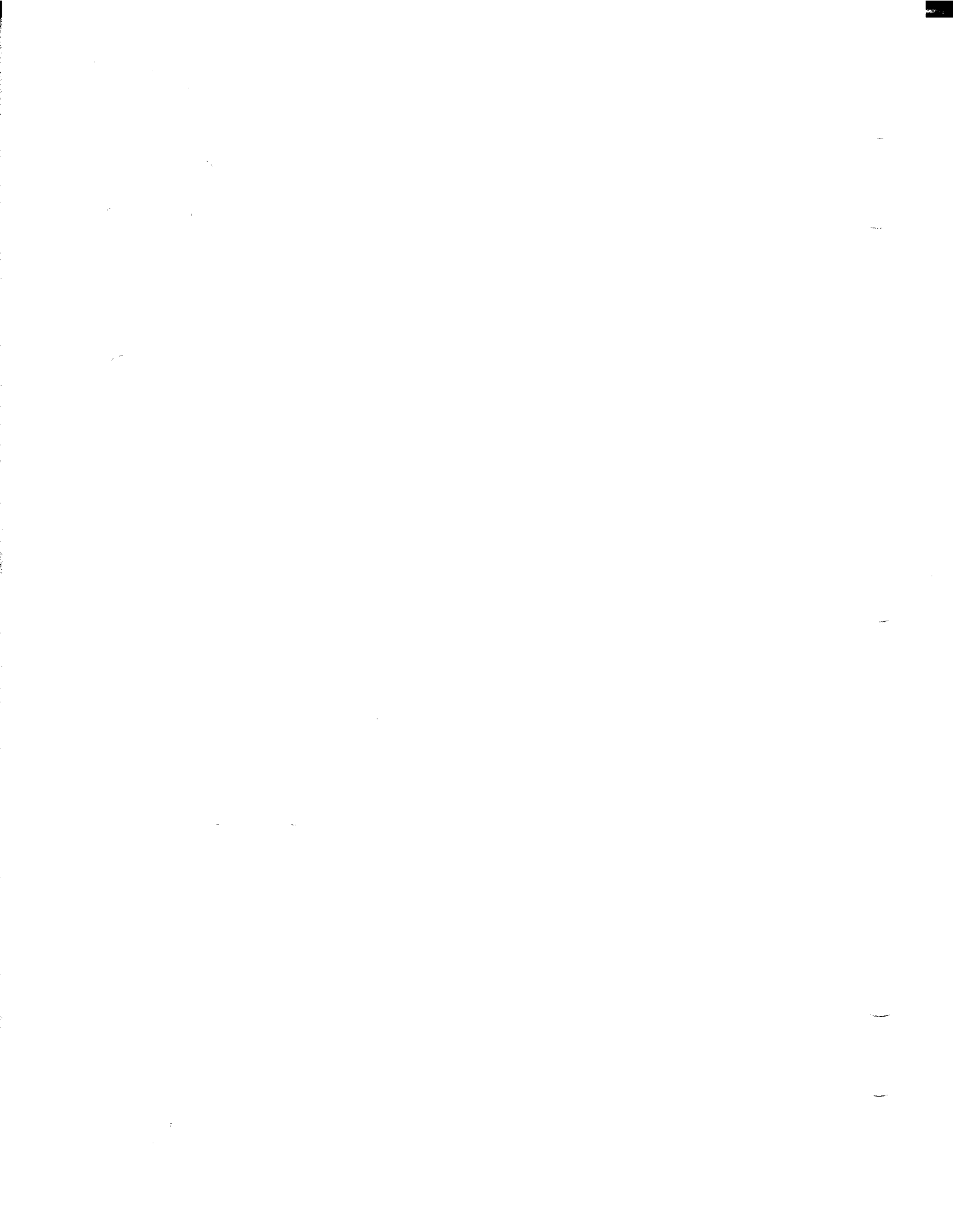

CHAPTER 4
FUEL SYSTEM MAINTENANCE

INDEX

Procedure	Page
Air Cleaner Fan Repair	4-2
Fuel Tank Repair	4-40
Fuel Primer Pump Repair	4-64
Fuel Primer Pump Piston Rod Assembly Repair	4-70
Fuel Primer Pump Inlet Valve Assembly Repair	4-73
Fuel Primer Pump Outlet Valve Assembly Repair	4-74
Fuel Lines Replacement - Primer Pump Lines (Inlet) (Outlet) From Bulkhead to Engine Compartment	4-76
Accelerator Control Linkage Assembly Replacement	4-80
Accelerator Control Linkage Assembly Repair	4-86

AIR CLEANER FAN REPAIR (Sheet 1 of 7)

PROCEDURE INDEX

PROCEDURE	PAGE
Disassembly	4-2
Cleaning and Inspection	4-5
Testing	4-5
Assembly	4-6

TOOLS: Flat-tip screwdriver with 1/4 in. blade
 Pliers
 Air supply source
 Vise
 Hammer
 1/2 in. socket with 1/2 in. drive
 Ratchet with 1/2 in. drive
 Rule
 Flat-tip screwdriver with 3/8 in. blade

TEST EQUIPMENT: Multimeter
 24 volt power supply

SUPPLIES: Dry cleaning solvent (Item 12, Appendix B)
 Rags
 Blower fan parts kit (5703549)

REFERENCE: TM 5-5420-226-20

DISASSEMBLY:

1. Using 3/8 inch screwdriver, remove screw (A) and lockwasher (B) securing retaining strap (C) holding both leads to housing (D).
2. Remove retaining strap (C) and lead (E).
3. Using screwdriver, remove 10 screws (F) and lockwashers (G) attaching cover (H) to impeller housing (D).
4. Separate cover (H) from housing (D).

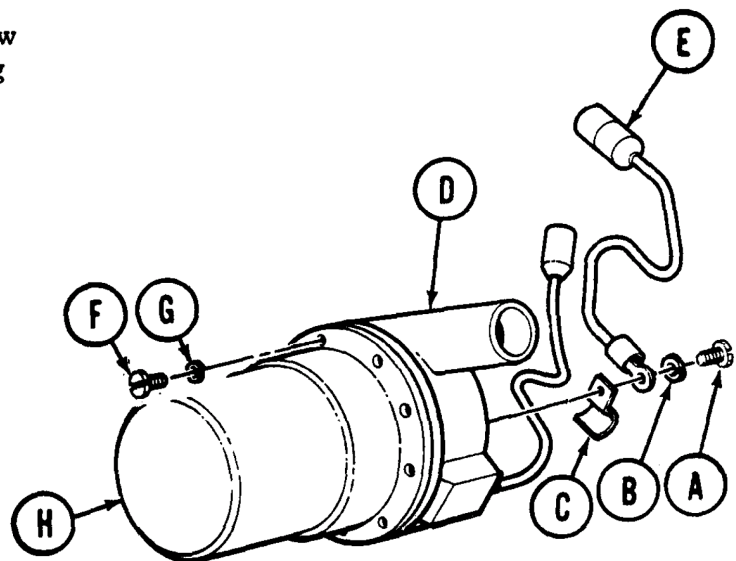

Go on to Sheet 2

TA108284

AIR CLEANER FAN REPAIR (Sheet 2 of 7)

5. Remove preformed packing (J) from motor (K).
6. Using 1/4 inch flat-tip screwdriver, remove screw and washer (L) securing ground strap (M).
7. Using 1/4 inch flat-tip screwdriver, remove screw and washer (N), securing retaining strap (P), brush lead (Q), and power lead (R).

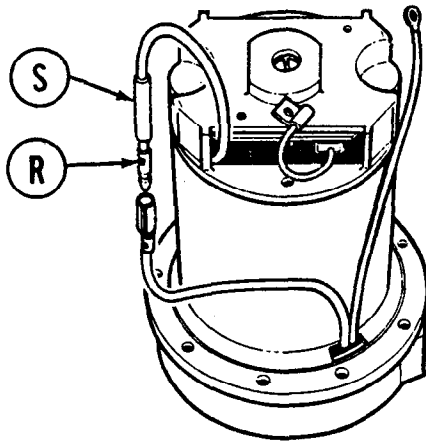
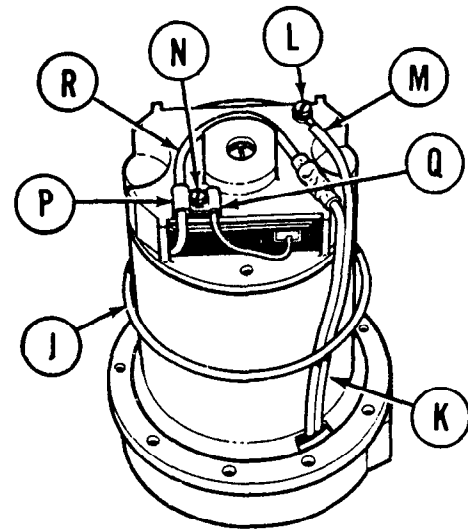

8. Slide insulator (S) aside to expose lead (R). Pull lead (R) apart at connector and remove insulator (S) by sliding forward.

9. Using 1/4 inch flat-tip screwdriver, remove four screws (T) and lockwashers (U) securing capacitor and leads (V). Pull leads and capacitor (V) out from housing (D).

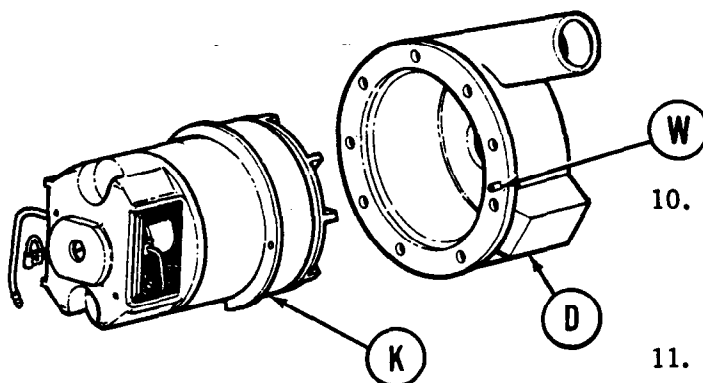
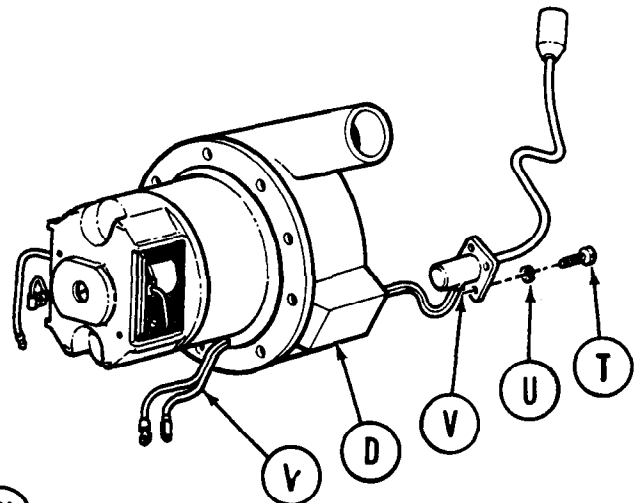

10. Holding motor (K) in one hand, tap housing (D) with hammer to loosen motor from housing. Remove motor (K) from housing (D).
11. Using pliers, remove spring pin (W) from housing (D).

Go on to Sheet 3

TA108285

AIR CLEANER FAN REPAIR (Sheet 3 of 7)

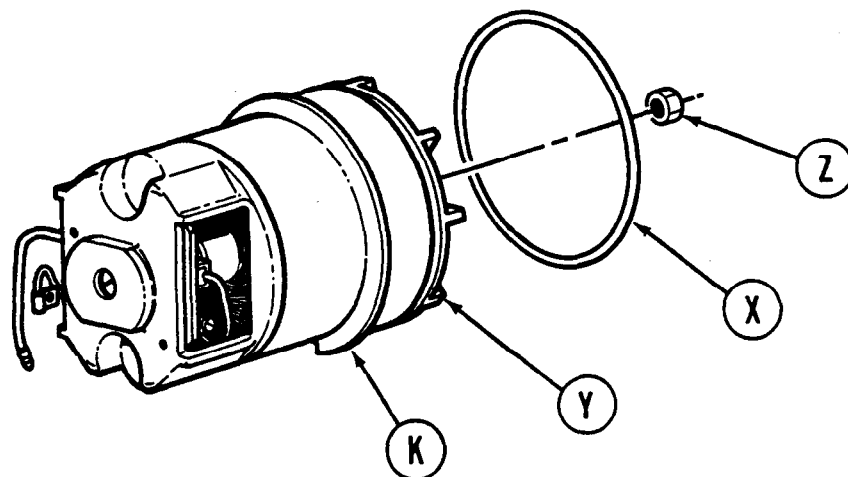

12. Remove packing (X) from motor (K). Throw packing away.
13. Hold impeller (Y) and using 1/2 inch socket with ratchet, remove nut (Z). Throw nut away.

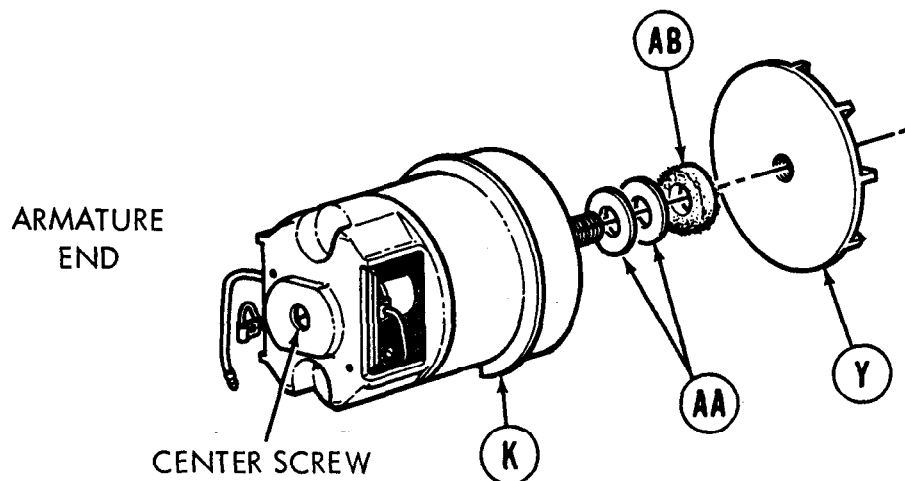

14. Using 3/8 inch flat-tip screwdriver to hold center screw (hidden) at armature end of motor (K), unscrew impeller (Y) from threaded shaft.
15. Remove shim washers (AA) and felt washer (AB). Throw washers away.

Go on to Sheet 4

TA108286

AIR CLEANER FAN REPAIR (Sheet 4 of 7)**CLEANING AND INSPECTION:**

- Using dry cleaning solvent (Item 12, Appendix B) and rag, clean all parts.

WARNING

Compressed air used for cleaning purposes will not exceed 30 psi. Use only with effective chip guarding and personnel protective equipment (goggles/shield, gloves, etc.).

- Dry parts with compressed air.
- Check both leads for fraying, torn insulation or oil soakage. Replace leads if damaged.
- Using multimeter (ohms scale), check leads for continuity. If continuity does not exist replace leads.
- Check cover and impeller for damage. If parts are damaged replace them.

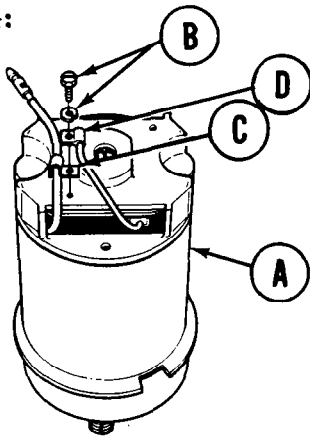
TESTING:

- Secure air cleaner blower motor (A) to bench with vise so motor is stable. Using screwdriver install screw and lockwasher (B), clip (C) and brush lead (D) to motor (A) as shown.

- Connect motor to 24 volt power source with (+) connection to lead (E) and (-) connection to lead (D).
- Using multimeter, check voltage for a reading of 24 volts.
- Using multimeter, check amperage for a reading of not more than 7.5 amps. Disconnect motor from power source.
- If voltage or current readings do not conform to those stated in steps 3 and 4, replace motor.
- Remove motor from vise.

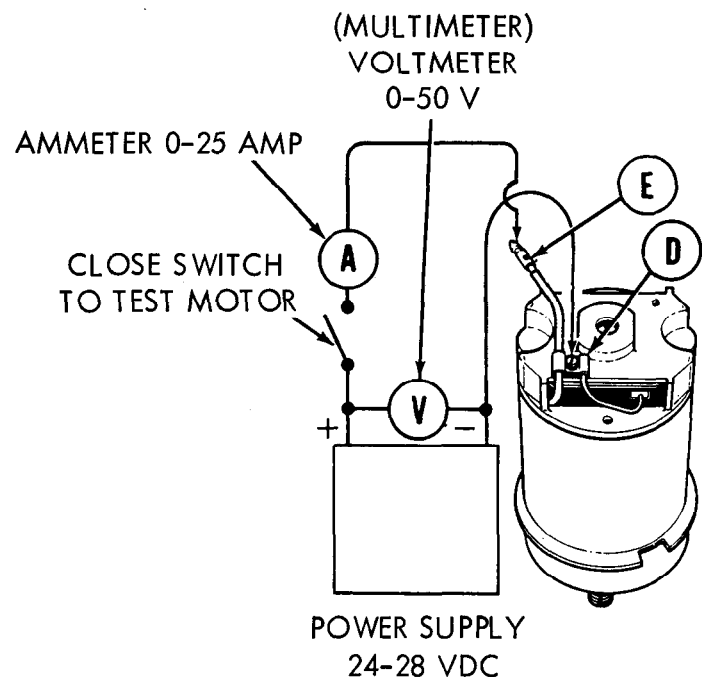

Go on to Sheet 5

TA108287

AIR CLEANER FAN REPAIR (Sheet 5 of 7)

ASSEMBLY:

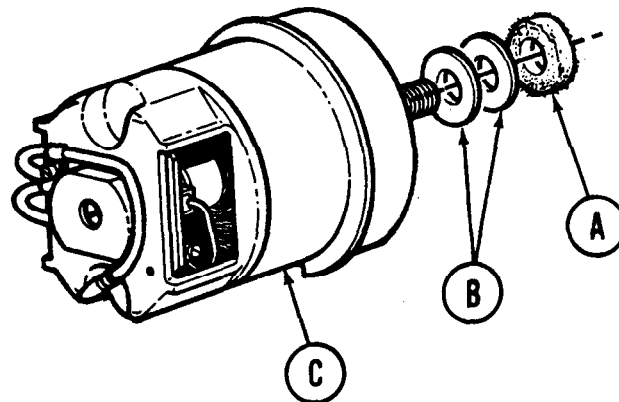

1. Position new felt washer (A) and two new shim washers (B) onto threaded shaft of motor (C).

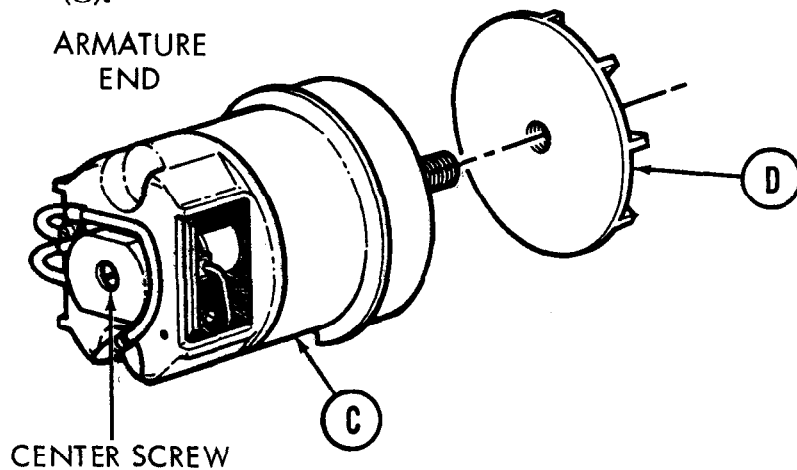

2. Using screwdriver to hold center screw at armature end of motor (C), screw impeller (D) onto threaded shaft of motor.

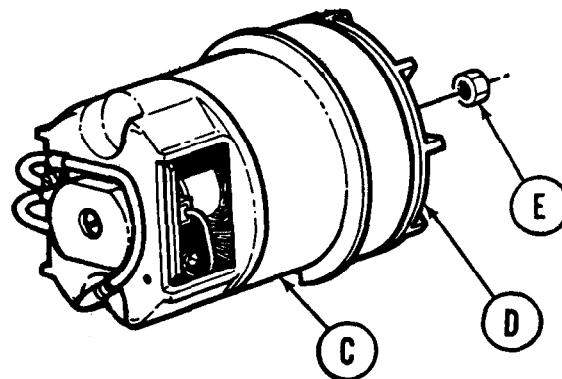

3. Position new nut (E) onto threaded shaft of motor (C).
4. Using screwdriver to hold end of shaft, use socket and ratchet to tighten nut (E) securing impeller (D) onto shaft.

Go on to Sheet 6

TA108288

AIR CLEANER FAN REPAIR (Sheet 6 of 7)

- Using a rule, measure distance between outside end of vanes and flange on motor (C).

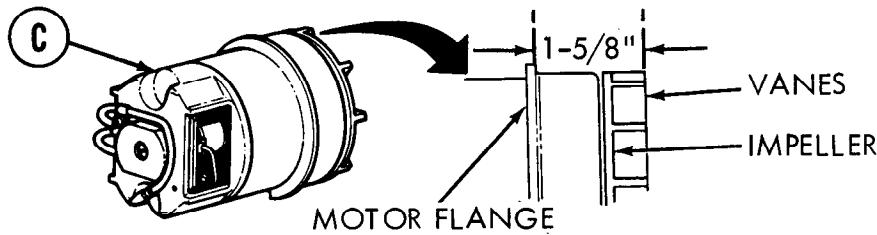

- This distance should be 1-5/8 inch. If distance is not correct, remove impeller (D) and add on (or take away) shim washers (B) as necessary.

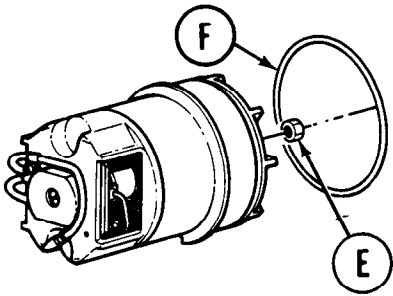
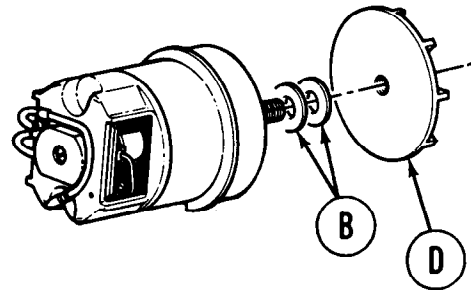

- Using socket with ratchet, install nut (E) again.
- Install new packing (F) in motor groove.

- Using hammer, install spring pin (G) in housing (H) by gently tapping pin into hole until it bottoms.

NOTE

It will be necessary to guide capacitor leads (J) through openings of housing (H) and motor (C) prior to step 10.

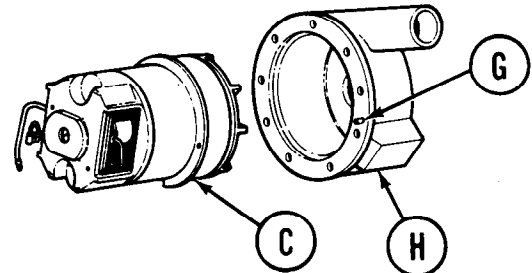

- Insert leads (J) and capacitor (K) into mounting place on housing (H) and through opening in flange of motor (C).
- Install motor (C) into housing (H) aligning hole in motor flange with pin (G) in housing flange.
- Using screwdriver, install four screws (L) and lockwashers (M) securing capacitor (K).

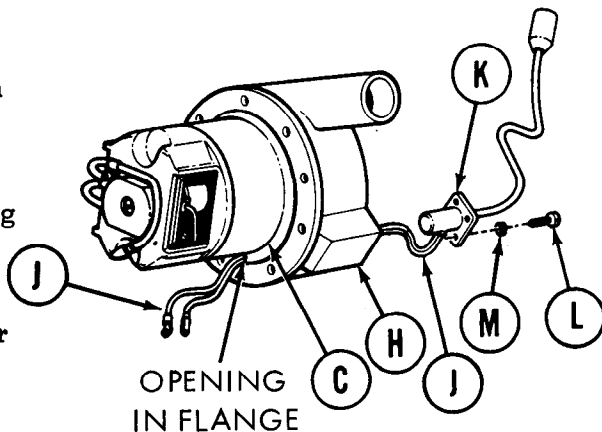

Go on to Sheet 7

TA108289

AIR CLEANER FAN REPAIR (Sheet 7 of 7)

13. Using flat-tip screwdriver, install screw (N) and lockwasher (P), to secure capacitor ground strap (Q) to armature end of motor (C).
14. Slide insulator (R) over end of capacitor lead (S) and connect lead (S) to lead (T) at end of motor as shown, then slide insulator (R) over connectors.

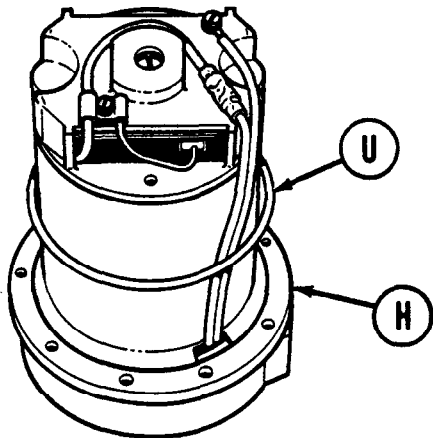
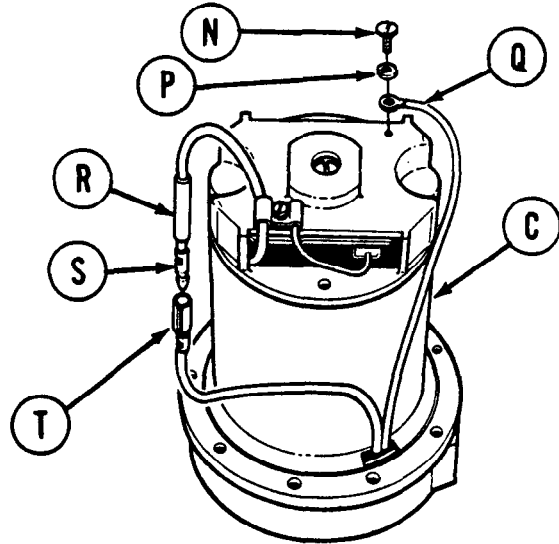

15. Install new packing (U) in groove in housing (H).

16. Position cover (V) to housing (H).
17. Install 10 screws (W) with 10 lockwashers (X) to secure cover (V) to housing (H).
18. Using screwdriver, tighten 10 screws (W).

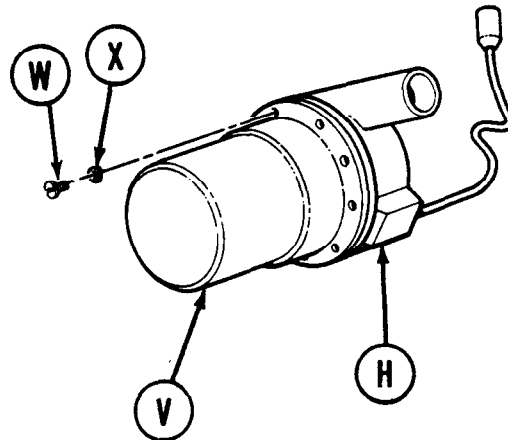

19. Place retaining clamp (Y) in position over both electrical leads (Z). Using screwdriver, install clamp (Y) to housing (K) with lockwasher (AA) and screw (AB).
20. Using screwdriver, tighten screw (AB).
21. Install air cleaner blower fan (TM 5-5420-226-20).

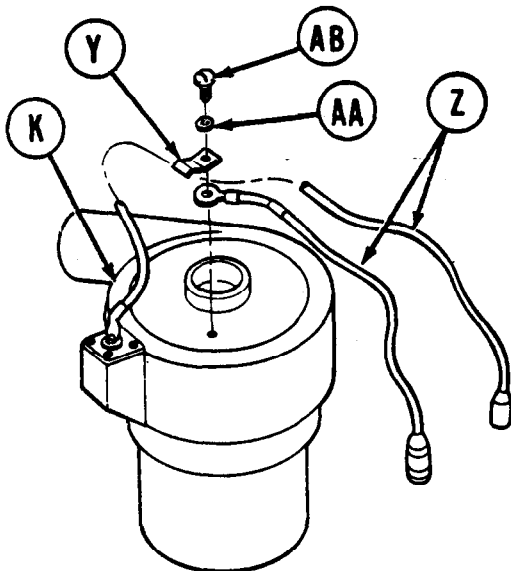

End of Task

TA108290

All data on pages 4-9 thru 4-39 deleted.

FUEL TANK REPAIR (Sheet 1 of 2)

TOOLS: Steam cleaner
Radiator repair kit
Coil insert thread tool kit
Tap and die set
Depth gage
Low pressure compressed air

FABRICATED TOOLS: Covers (Filler and crossover hose openings) (Fig. D-3, Appendix D)

SUPPLIES: Detergent (Item 11, Appendix B)
Adhesive (Item 1, Appendix B)
Cleaning compound (Item 5, Appendix B)

REFERENCE: TM 9-237

PRELIMINARY PROCEDURES: Remove right fuel tank (TM 5-5420-226-20).
Remove left fuel tank (TM 5-5420-226-20).

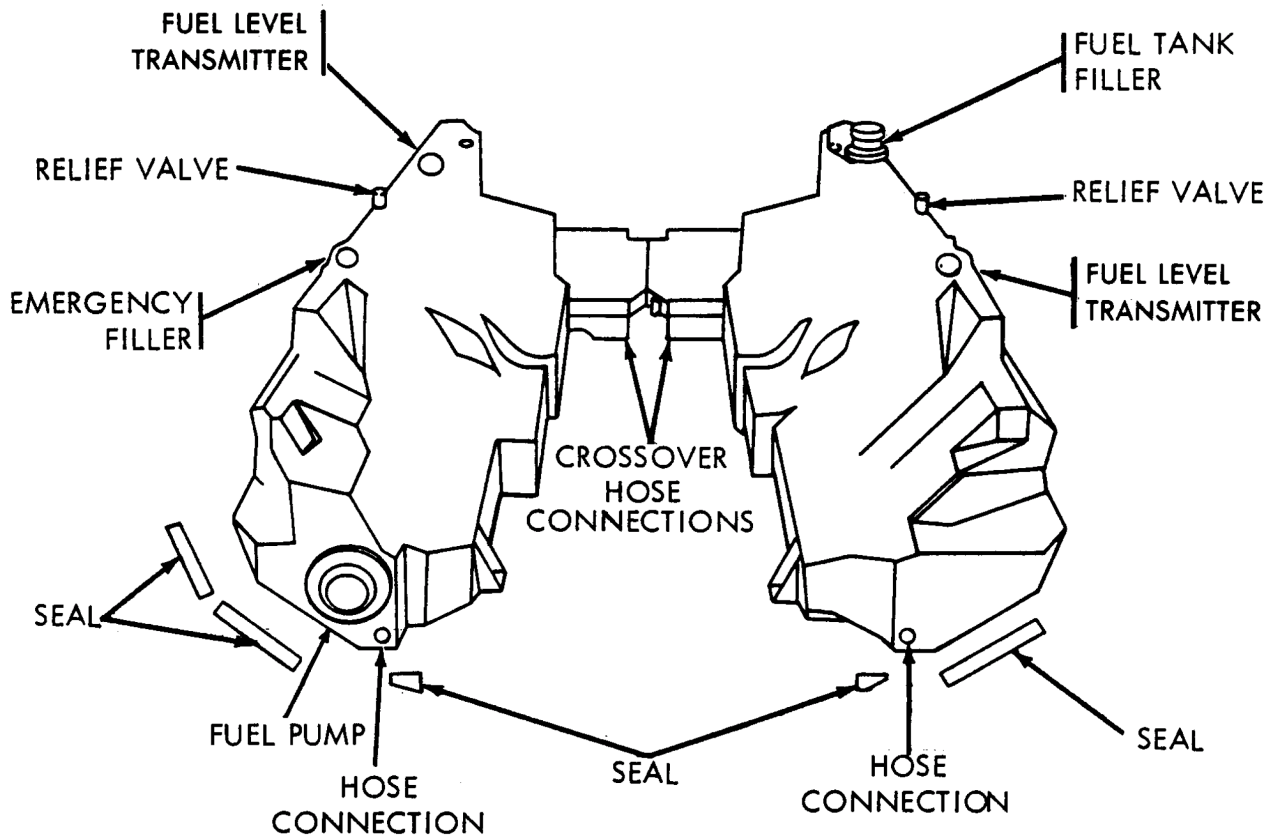

CLEANING AND INSPECTION:

1. Using steam cleaner, apply a solution of cleaning compound (Item 5, Appendix B) and water to exterior and interior of fuel tanks. Rinse tank thoroughly with hot water after cleaning.

Go on to Sheet 2

TA108322

FUEL TANK REPAIR (Sheet 2 of 2)

2. Inspect for cracks, fractures, deformation, and nicks. Fuel tank must be free of cracks, fractures, and deformation, and must be free of nicks and scores in excess of 1/32 inch deep.
3. Inspect threaded screw holes for worn or damaged threads.
4. Inspect for flaked or chipped paint. Paint flaked or chipped areas (TM 43-0139).
5. Inspect all welds for defects.
6. Inspect seals that are bonded to hull for looseness and wear.

REPAIR:

1. To weld cracks, fractures, broken or damaged welds, or nicks and scores, refer to TM 9-237.
2. Replace loose or worn seals using adhesive.
3. Repair worn or damaged threads by chasing with a proper size tap or by installation of a new coil insert. Paint welded areas, refer to TM 43-0139.

TEST:

1. Install fabricated covers (Fig. D-3, Appendix D) and new gaskets on crossover hose opening and on tank filler openings. Seal all other openings except one with radiator repair kit. In the remaining opening install a suitable fitting from the radiator repair kit and introduce compressed air into fuel tank until a pressure of 3 psi has been reached.
2. Hold pressure at 3 psi and inspect all joints for leaks by applying a soap (Item 11, Appendix B) and water solution on the joints.
3. There must be no leakage. Leakage, if present, will be indicated by the presence of air bubbles in the soapy water area, or by loss of air pressure as indicated by the gage.
4. Relieve pressure and rinse exterior of fuel tank with hot water. Allow to dry.
5. Install right fuel tank (TM 5-5420-226-20).
6. Install left fuel tank (TM 5-5420-226-20).

End of Task

All data on pages 4-42 thru 4-63 deleted.

FUEL PRIMER PUMP REPAIR (Sheet 1 of 6)

PROCEDURE INDEX

PROCEDURE	PAGE
Test	4-64
Disassembly	4-65
Cleaning and Inspection	4-67
Assembly	4-68

TOOLS: Vacuum gage (0 to 50 in.)
 Pressure gage (0 to 300 psi) w/release valve
 Long round nose pliers (needle nose)
 Flat-tip screwdriver
 7/16 in. combination box and open end wrench
 Diagonal cutting pliers
 1-1/2 in. open end wrench
 Vise
 9/16 in. combination box and open end wrench
 1-1/8 in. combination box and open end wrench

SUPPLIES: Parts kit (5704213)
 Fuel source
 Lockwire (Item 27, Appendix B)
 Rags

TEST:

NOTE

If any test fails, pump must be repaired or replaced.

1. Connect inlet side of primer pump (A) to a fuel source to lubricate internal part. Pump handle.
2. Remove from fuel source, then pump handle until no fuel flows from outlet side of primer pump.
3. Connect vacuum gage (B) to inlet side of primer pump (A).
4. Operate pump handle. Pump must maintain a minimum of 12 inches of vacuum while pumping.
5. Remove vacuum gage from pump.

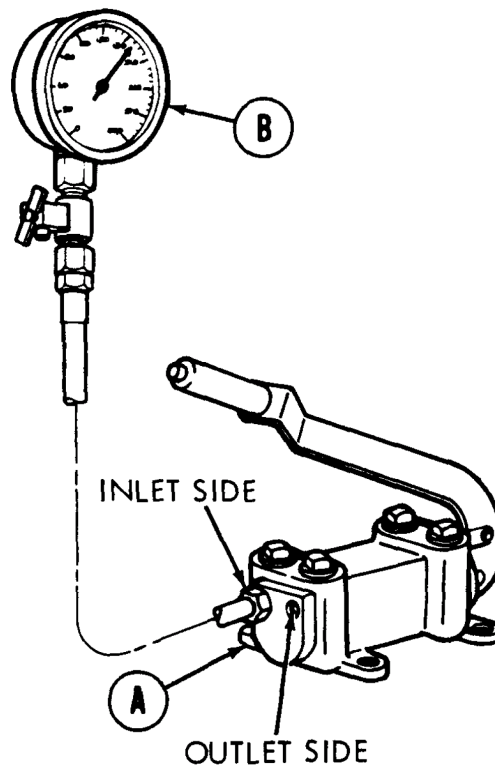

Go on to Sheet 2

TA108345

FUEL PRIMER PUMP REPAIR (Sheet 2 of 6)

6. Reconnect inlet side of primer pump (A) to fuel source.
7. Attach pressure gage (C) to outlet side of primer pump (A).
8. Operate primer pump handle. Pump should develop minimum pressure of 200 psi, with no external leakage.
9. Relieve pressure at gage (C).
10. With pressure gage (C) still connected to primer pump (A), operate handle until 30 psi has been obtained.
11. Remove inlet line from primer pump (A).
12. Observe for internal leakage. Leakage should not exceed 20 drops per minute.

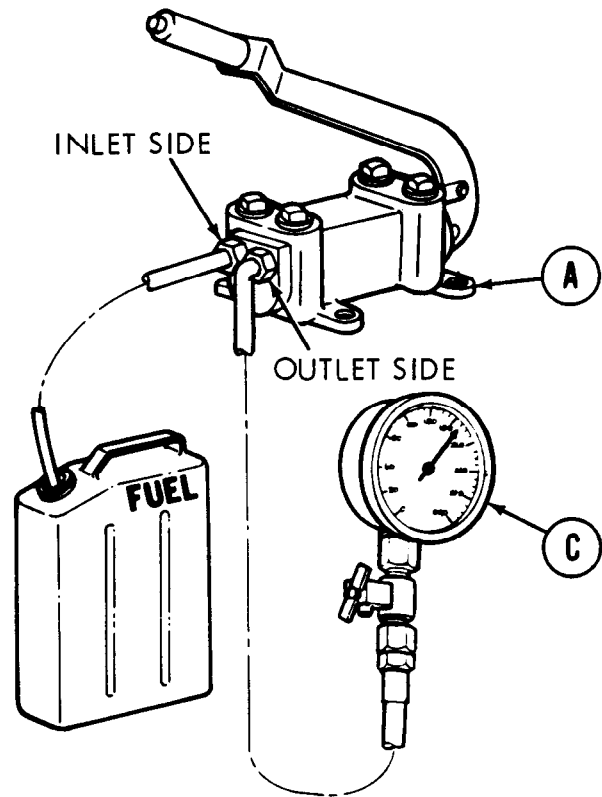

DISASSEMBLY:

NOTE

It may be necessary to place primer pump in vise during disassembly.

1. Using needle nose pliers, remove three cotter pins (A), three pins (B) and one link (C) securing handle assembly (D) to primer pump (E).
2. Using 7/16 inch wrench, remove screw (F) and clamp (G) from handle assembly (D).
3. Using diagonal pliers, cut and remove lockwire (H). Throw lockwire away.

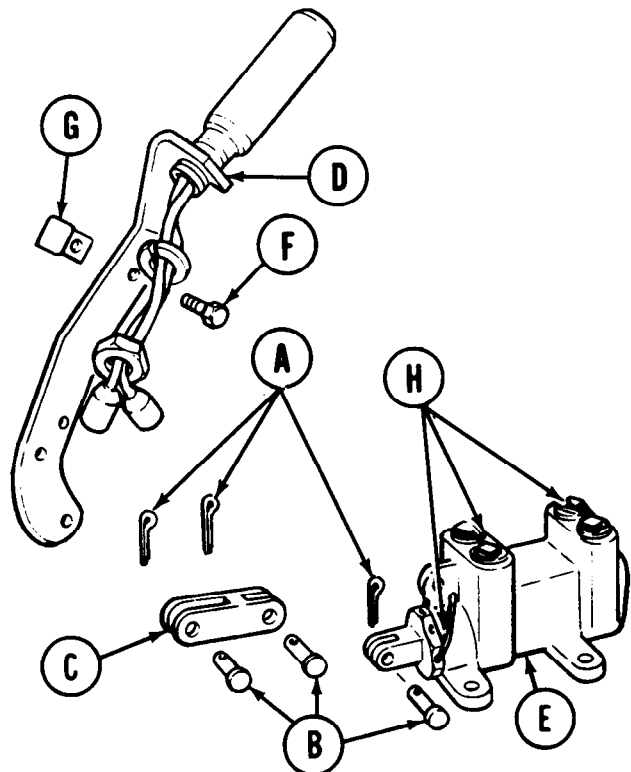

Go on to Sheet 3

TA108346

FUEL PRIMER PUMP REPAIR (Sheet 3 of 6)

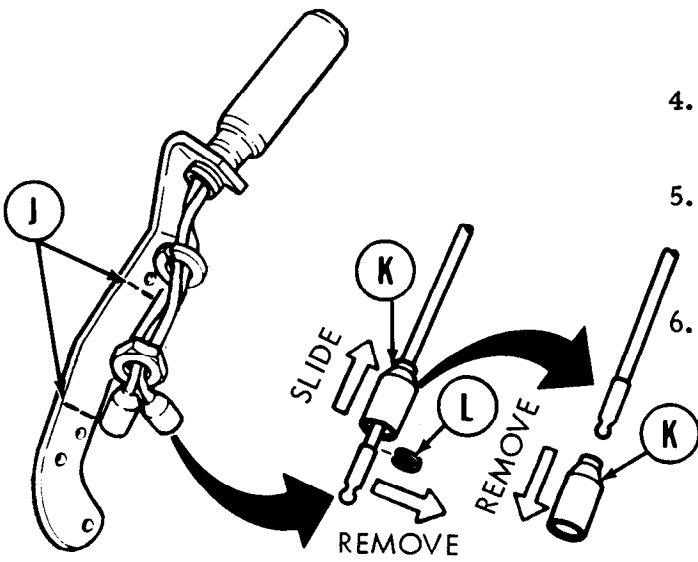

4. Place handle assembly in vise with vise head between points (J) as shown in picture.
5. Slide two connector shells (K) back on leads and remove two slotted washers (L).
6. Remove connector shells (K) by sliding down and off.

7. Using 1-1/8 inch wrench, remove nut (M) and lockwasher (N) from operating handle (P).

8. Remove operating handle (P) from lever (Q).

9. Remove lever (Q) from vise and set aside.

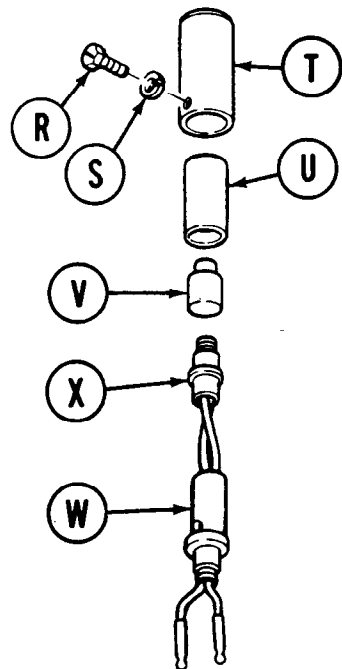
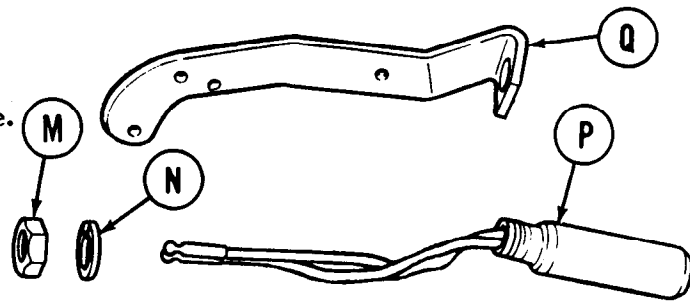

10. Using screwdriver, remove screw (R) and lockwasher (S) from handle (T).
11. Remove handle (T), upper sleeve (U) and plunger (V).
12. Remove lower sleeve (W) from switch assembly (X).

Go on to Sheet 4

TA108347

FUEL PRIMER PUMP REPAIR (Sheet 4 of 6)

13. Using 1-1/2 inch wrench, remove rod assembly (Y) from primer pump (E). If rod assembly requires repair, go to page 4-70.

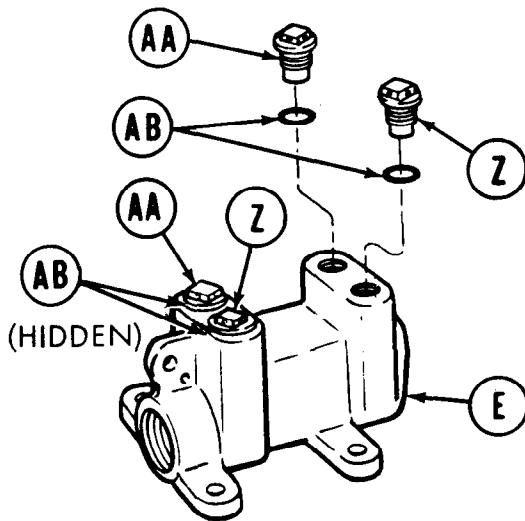
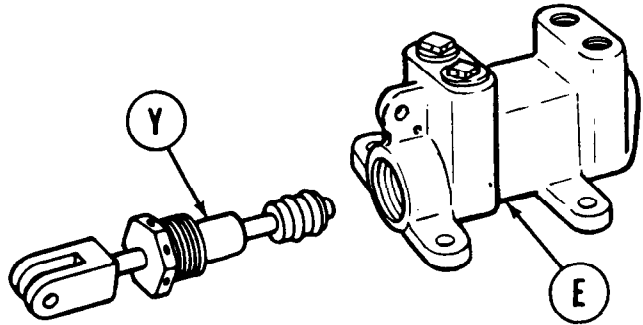

14. Using 9/16 inch wrench, remove inlet valve (Z) and outlet valve (AA) from primer pump (E). If inlet valve requires repair, go to page 4-73. If outlet valve requires repair, go to page 4-74.
15. Remove and throw away preformed packings (AB) located in primer pump (E).

CLEANING AND INSPECTION:

1. Clean handle, lever, sleeves, and retainer as required.
2. Inspect switch assembly for dirt or corrosion. Clean if necessary. If leads are cut or damaged, replace.
3. Inspect nuts, screws, and valves for worn or damaged threads. Replace as required.

Go on to Sheet 5

TA108348

FUEL PRIMER PUMP REPAIR (Sheet 5 of 6)

ASSEMBLY:

1. Using 9/16 inch wrench, install two inlet valves and new preformed packings (A) and two outlet valves and new preformed packings (B) in primer pump (C).
2. Install new lockwire (Item 26, Appendix B) (D) securing inlet and outlet valves (A and B).
3. Install rod assembly (E) in primer pump (C).
4. Using 1-1/2 inch wrench, install and tighten gland (F) of rod assembly (E) into primer pump (C).
5. Install new lockwire (Item 27, Appendix B) (G) through holes (H) securing rod assembly (E) to primer pump (C).

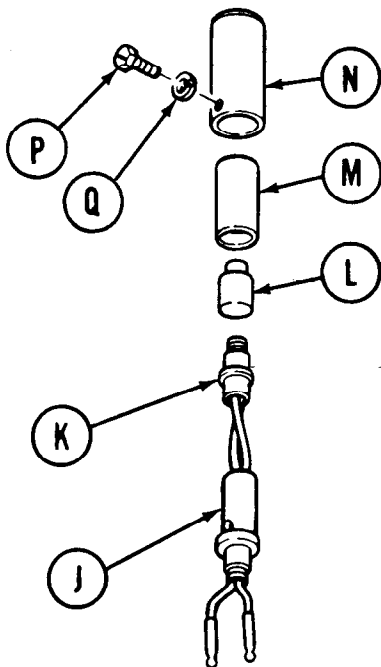
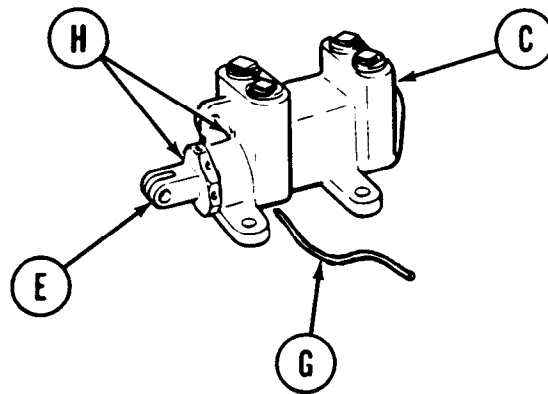
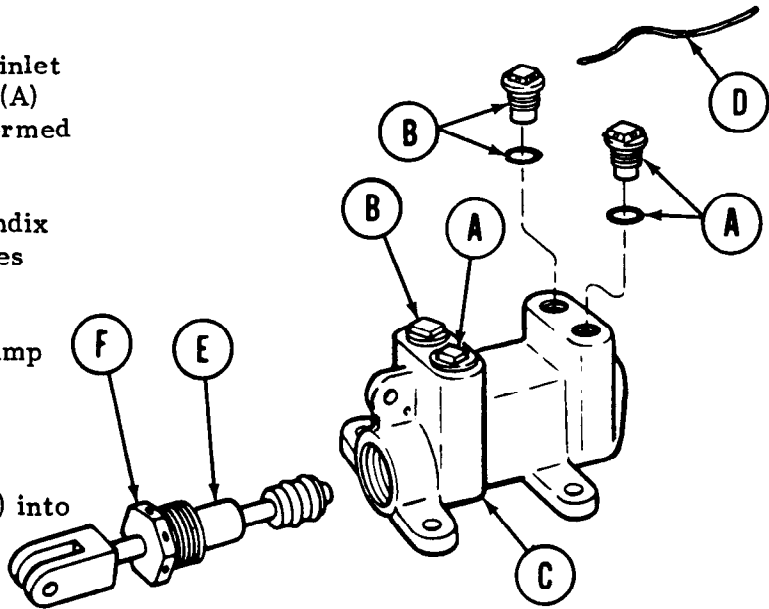

6. Install lower sleeve (J) on switch assembly (K).
7. Place plunger (L) over switch assembly (K).
8. Place flat end of upper sleeve (M) over switch assembly (K).
9. Place handle (N) over assemblies (J, K, L, M) and align holes in handle (N) and lower sleeve (J).
10. Using screwdriver, install screw (P) and lockwasher (Q).

Go on to Sheet 6

TA108349

FUEL PRIMER PUMP REPAIR (Sheet 6 of 6)

11. Place lever (R) in vise.
12. Place operating handle (S) in position on lever (R).
13. Using 1-1/8 inch wrench, install nut (T) and lockwasher (U).
14. Slide two connector shells (V) on two leads of switch assembly (K).
15. Install two slotted washers (W) and slide connector shells (V) down until seated.
16. Remove handle assembly from vise.

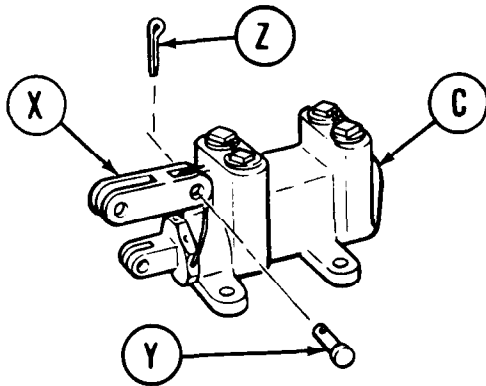
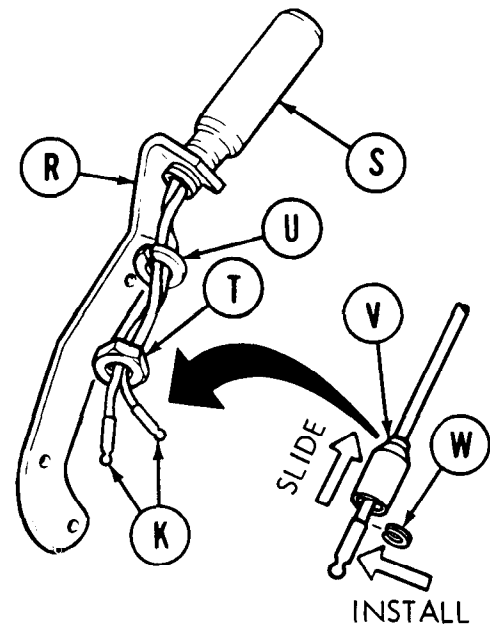

17. Place link (X) in position on primer pump (C).
18. Install pin (Y) through link (X) and primer pump (C).
19. Using pliers, install cotter pin (Z).

20. Place handle assembly (AA) in position on primer pump (C).
21. Install two pins (AB).
22. Using pliers, install two cotter pins (AC).
23. Place clamp (AD) in position.
24. Using 7/16 inch wrench, install screw (AE).
25. Perform functional tests (page 4-64).

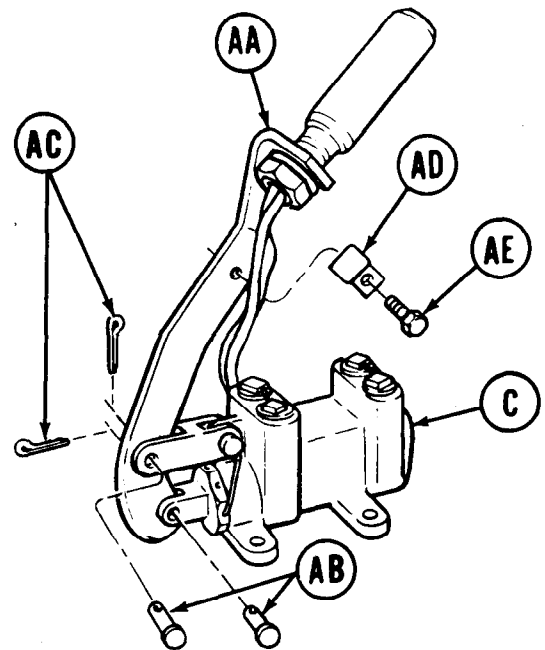

End of Task

TA108350

FUEL PRIMER PUMP PISTON ROD ASSEMBLY REPAIR (Sheet 1 of 3)

TOOLS: 10 in. adjustable wrench
 Long round nose pliers (needle nose)
 7/16 in. open end wrench
 Hammer
 1/8 in. punch
 Inside micrometer
 Outside micrometer

SUPPLIES: Parts kit (5704213)
 Cotter pin

PRELIMINARY PROCEDURE: Remove piston rod assembly from primer pump (page 4-65, steps 1-3 and page 4-67, step 13)

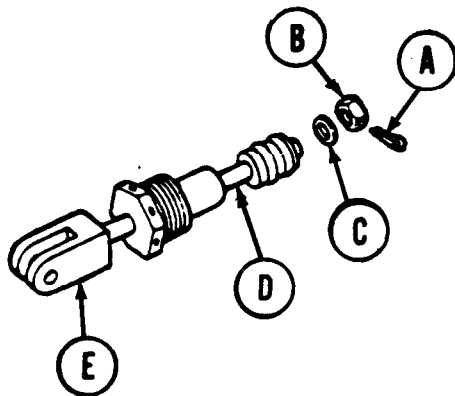

DISASSEMBLY:

1. Using pliers, remove cotter pin (A).
 Throw cotter pin away.
2. Using 7/16 inch wrench, remove nut (B) and flat washer (C) from piston rod (D) while holding clevis (E) with adjustable wrench.

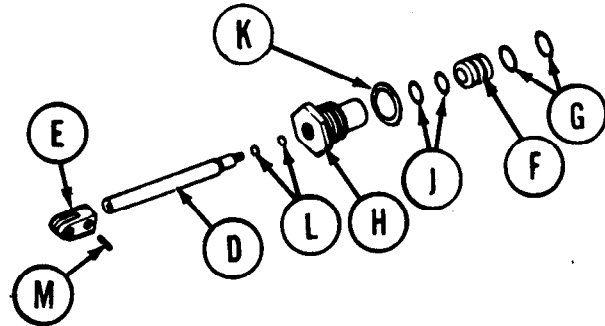

3. Slide piston (F) off rod (D).
4. Remove and throw away two preformed packings (G) from piston (F).
5. Slide gland (H) from rod (D).
6. Remove two preformed packings (J) from inside of gland (H). Throw packings away.
7. Remove preformed packing (K) and throw away.
8. Remove two preformed packings (L) from rod (D) and throw away.
9. Using hammer and punch, remove pin (M) from clevis (E) and separate clevis (E) from rod (D).

Go on to Sheet 2

TA108351

FUEL PRIMER PUMP PISTON ROD ASSEMBLY REPAIR (Sheet 2 of 3)

CLEANING AND INSPECTION:

1. Clean all parts of piston assembly as required.
2. Using an inside and outside micrometer, check parts for wear as indicated. Replace all parts that do not meet wear limits.

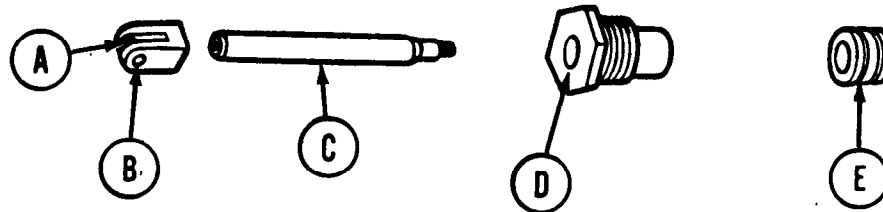

PRIMER PUMP WEAR LIMITS

Reference Letter	Point of Measurement	Size and fit of New Parts	Wear Limits
A	ID of clevis bore	0.248 to 0.253	0.256
B	Fit of pin in yoke	0.000 to 0.010L	0.008L
C	OD of piston rod	0.497 to 0.499	(*)
D	ID of gland	0.505 to 0.507	(*)
C-D	Fit of rod in gland	0.006L to 0.010L	(*)
E	OD of piston	0.990 to 0.995	(*)

An asterisk (*) in the wear limits column indicates part should be replaced when worn beyond limits given in size and fit of new parts column.

An L following a dimension indicates loose fit.

3. Inspect all parts for cracks or deformities. Replace as required.

Go on to Sheet 3

TA108352

FUEL PRIMER PUMP PISTON ROD ASSEMBLY REPAIR (Sheet 3 of 3)

ASSEMBLY:

1. Place clevis (A) in position on piston rod (B). Aline holes.
2. Using hammer, install pin (C).
3. Install two new packings (D) on piston rod (B).
4. Install two new packings (E) inside gland (F).
5. Install new packing (G) onto gland (F).
6. Slide gland (F) on piston rod (B).
7. Slide piston (H) on piston rod (B).
8. Install two new packings (J).

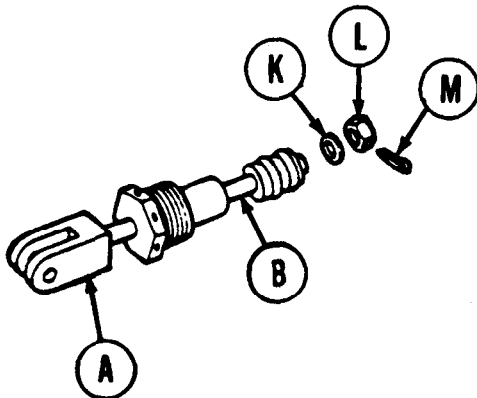
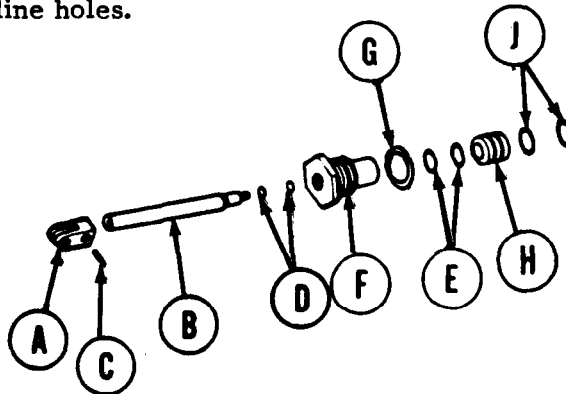

9. Using 7/16 inch wrench, install flat washer (K) and nut (L) on piston rod (B) while holding clevis (A) with adjustable wrench.
10. Using pliers, install cotter pin (M).
11. Install piston rod assembly in primer pump (page 4-68, steps 3-4 and page 4-69, steps 17-24).

End of Task

TA108353

FUEL PRIMER PUMP INLET VALVE ASSEMBLY REPAIR (Sheet 1 of 1)

TOOLS: Retaining ring pliers
6 in. steel rule

SUPPLIES: Lubricating oil (Item 17, Appendix B)
Parts kit (5704213)

PRELIMINARY PROCEDURE: Remove inlet valve assemblies from primer pump (page 4-65, step 3 and page 4-67, step 14)

NOTE

Repair of two inlet valve assemblies in primer pump is identical.

DISASSEMBLY:

1. Remove preformed packings (A and B) from valve assembly (C) and throw away packings.
2. Using pliers, remove retaining ring (D) from inside of valve assembly (C).
3. Remove spring (E) and ball bearing (F).

CLEANING AND INSPECTION:

1. Clean all parts of inlet valve assembly as required.
2. Using steel rule, check spring for wear. Free length of spring should be between $51/64$ inch to $13/16$ inch. Replace if not within limits.

ASSEMBLY:

1. Install ball bearing (F) and spring (E) in valve assembly (C).
2. Using retaining ring pliers, install retaining ring (D).
3. Apply lubricating oil (Item 17, Appendix B) to preformed packings (A and B).
4. Install new packings (A and B) on valve assembly (C).
5. Install inlet valve assembly in primer pump (page 4-68, steps 1 and 2).

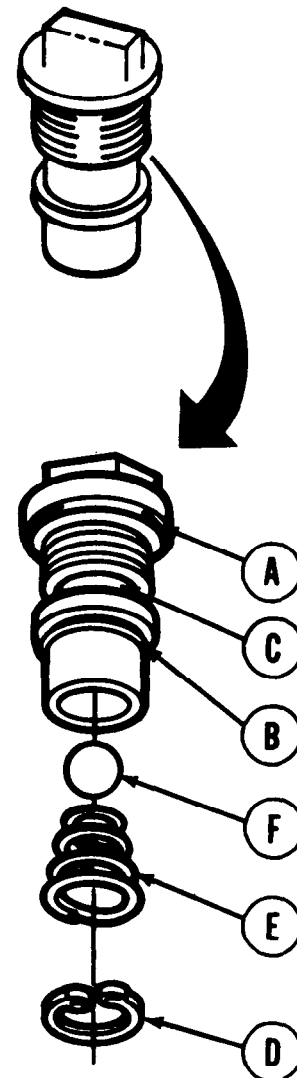

TA108354

End of Task

FUEL PRIMER PUMP OUTLET VALVE ASSEMBLY REPAIR (Sheet 1 of 2)

TOOLS: Retaining ring pliers (internal and external)
6 in. steel rule

SUPPLIES: Lubricating oil (Item 17, Appendix B)
Parts kit (5704213)

PRELIMINARY PROCEDURE: Remove outlet valve assemblies from primer pump
(page 4-65, step 3 and page 4-67, step 14)

NOTE

Repair of the two outlet valve assemblies in primer pump is identical.

DISASSEMBLY:

1. Remove packing (A) from valve (B).
Throw packing away.
2. Using retaining ring pliers, remove retaining ring (C) from primer pump housing (D).
3. Remove spring (E) and ball bearing (F) from pump housing (D).
4. Remove outlet valve (G) from pump housing (D).
5. Remove preformed packing (H) from pump housing (D). Throw packing away.

CLEANING AND INSPECTION:

1. Clean all parts of outlet valve assembly as required.
2. Using steel rule, measure length of spring. Spring should be between $51/64$ inch to $13/16$ inch. If not, replace.

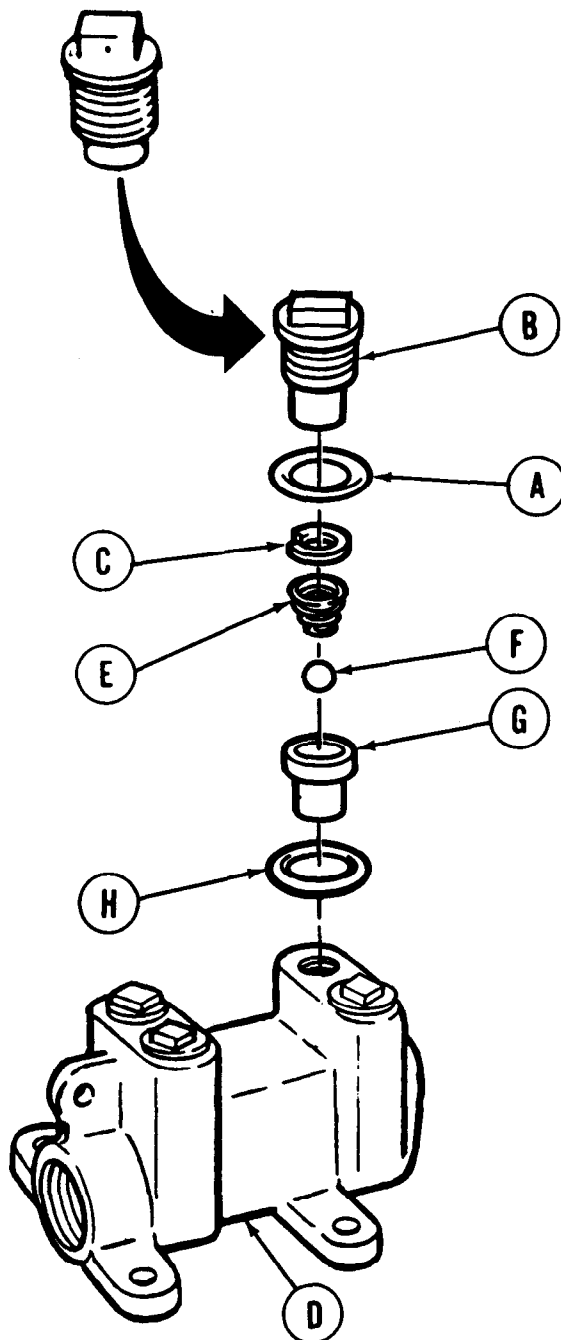

Go on to Sheet 2

TA108355

FUEL PRIMER PUMP OUTLET VALVE ASSEMBLY REPAIR (Sheet 2 of 2)**ASSEMBLY:****NOTE**

Apply lubricating oil (Item 17, Appendix B) to packing.

1. Install new preformed packing (A) into pump housing (B).
2. Install outlet valve (C) into pump housing (B).
3. Place ball bearing (D) and spring (E) in primer pump housing (B).
4. Using pliers, install retaining ring (F) in housing (B).
5. Place packing (G) on retainer (H).
6. Install outlet valve assemblies in primer pump (page 4-68).

End of Task

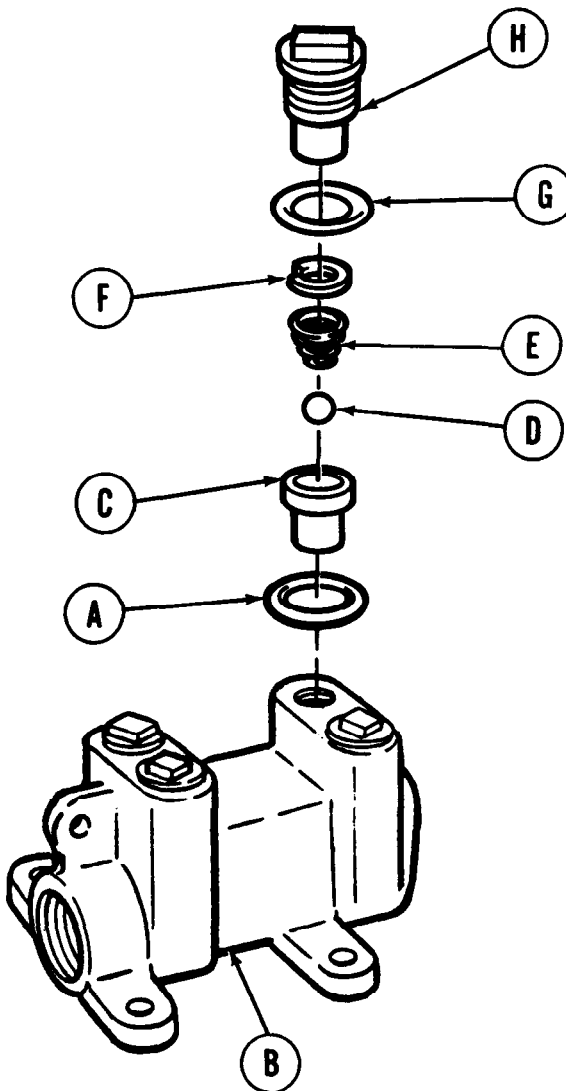

TA108356

FUEL LINES REPLACEMENT - PRIMER PUMP LINES (INLET) (OUTLET) FROM BULKHEAD TO ENGINE COMPARTMENT (Sheet 1 of 4)

PROCEDURE INDEX

PROCEDURE	PAGE
Removal	4-76
Installation	4-78

TOOLS: Ratchet with 1/2 in. drive
 7/16 in. socket with 1/2 in. drive
 5/8 in. combination box and open end wrench
 1/2 in. combination box and open end wrench
 9/16 in. combination box and open end wrench
 11/16 in. combination box and open end wrench

SUPPLIES: Clean rags

PRELIMINARY PROCEDURES: Remove left fuel tank (page 4-24)
 Remove bulkhead access cover (TM 5-5420-226-20)

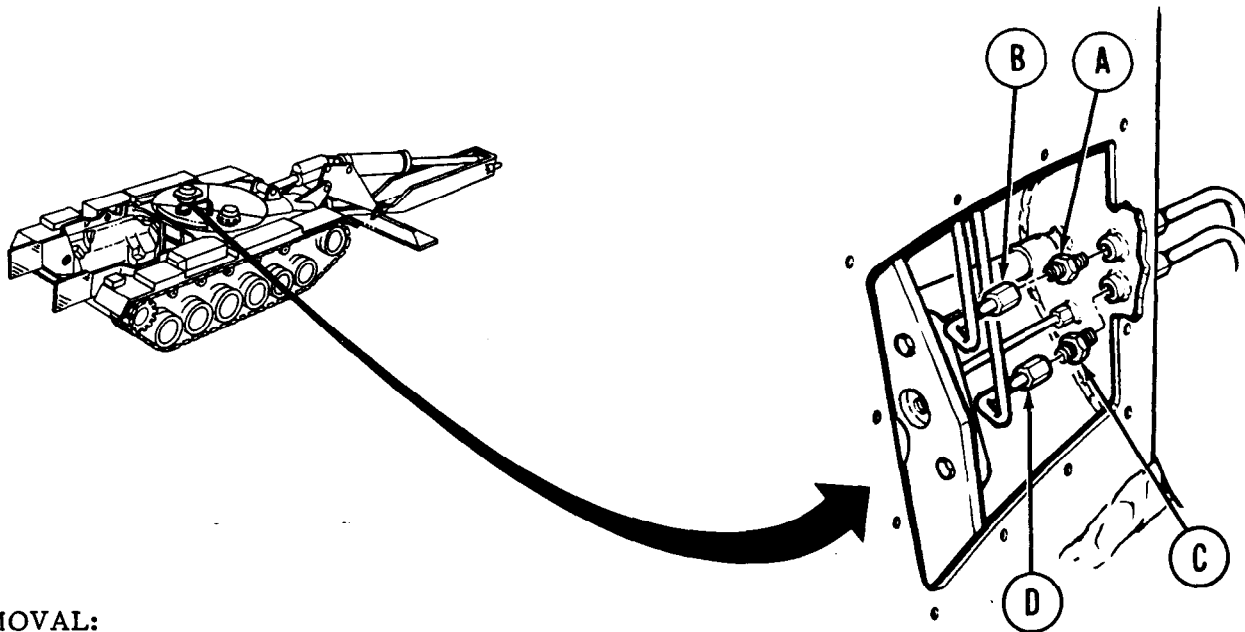

REMOVAL:

1. Using 11/16 inch wrench to hold nipple (A), use 9/16 inch wrench to disconnect tube assembly connecting nut (B).
2. Using 11/16 inch wrench to hold nipple (C), use 5/8 inch wrench to disconnect tube assembly connecting nut (D).
3. Place rags under nuts (B) and (D) to catch dripping fuel.

Go on to Sheet 2

TA108357

FUEL LINES REPLACEMENT - PRIMER PUMP LINES (INLET) (OUTLET) FROM BULKHEAD TO ENGINE COMPARTMENT (Sheet 2 of 4)

4. Using 7/16 inch socket, remove two screws (E), lockwashers (F), and four clamps (G) and (H).
5. Using 7/16 inch socket and 7/16 inch wrench, remove screw (J), clamp (K), lockwasher (L), and nut (M).

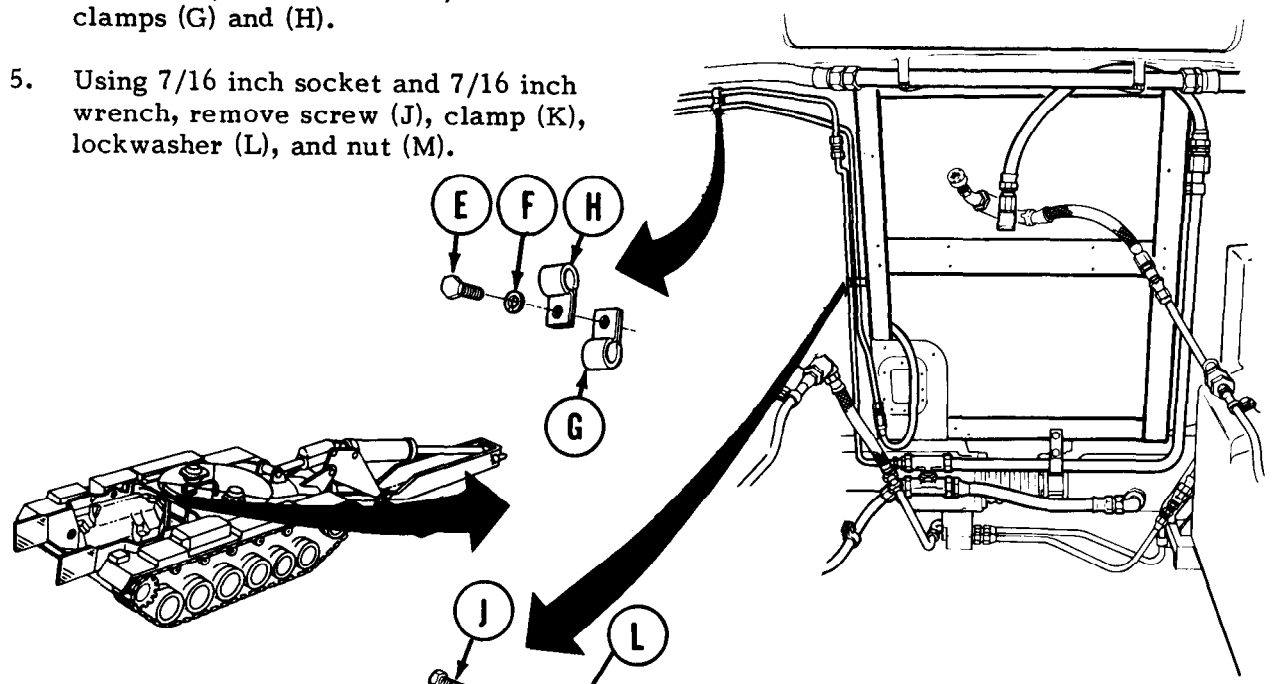

6. Using 1/2 inch wrench to hold adapter (N), use 5/8 inch wrench to disconnect tube assembly nut (P).
7. Using 1/2 inch wrench to hold adapter (Q), use 9/16 inch wrench to disconnect tube assembly nut (R).
8. Remove tube assemblies (S) and (T).

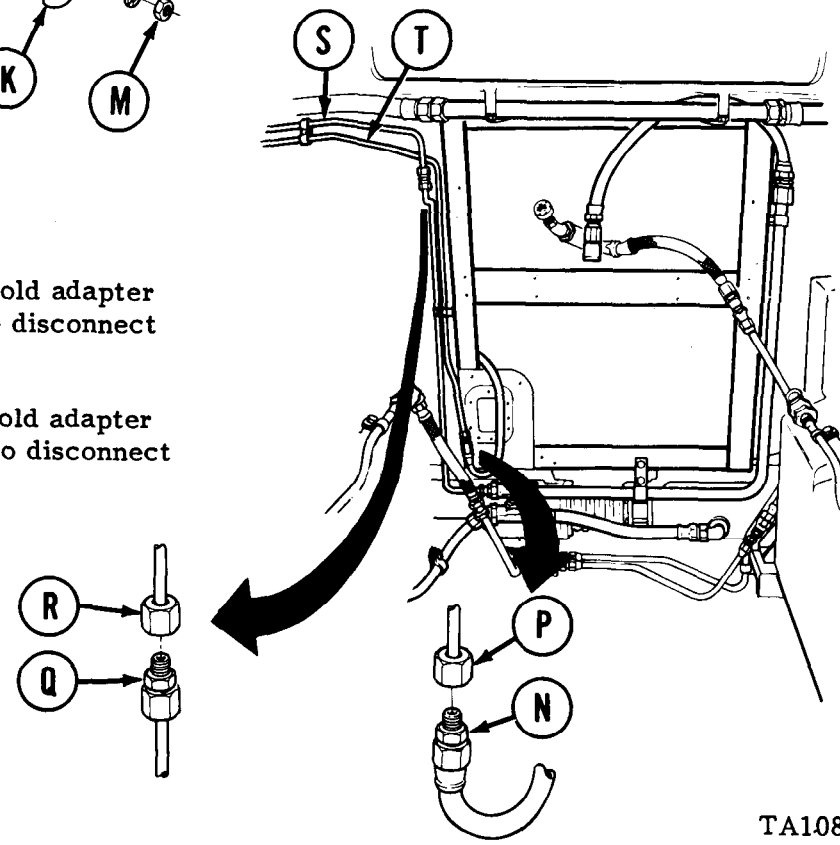

Go on to Sheet 3

TA108358

FUEL LINES REPLACEMENT - PRIMER PUMP LINES (INLET) (OUTLET) FROM BULKHEAD TO ENGINE COMPARTMENT (Sheet 3 of 4)

INSTALLATION:

1. Position tube assemblies (A) and (B) in place.
2. Using 1/2 inch wrench to hold adapter (C), use 5/8 inch wrench to connect tube assembly nut (D).
3. Using 1/2 inch wrench to hold adapter (E), use 9/16 inch wrench to connect tube assembly nut (F).
4. Position four clamps (G) and (H) on tube assemblies (A) and (B).

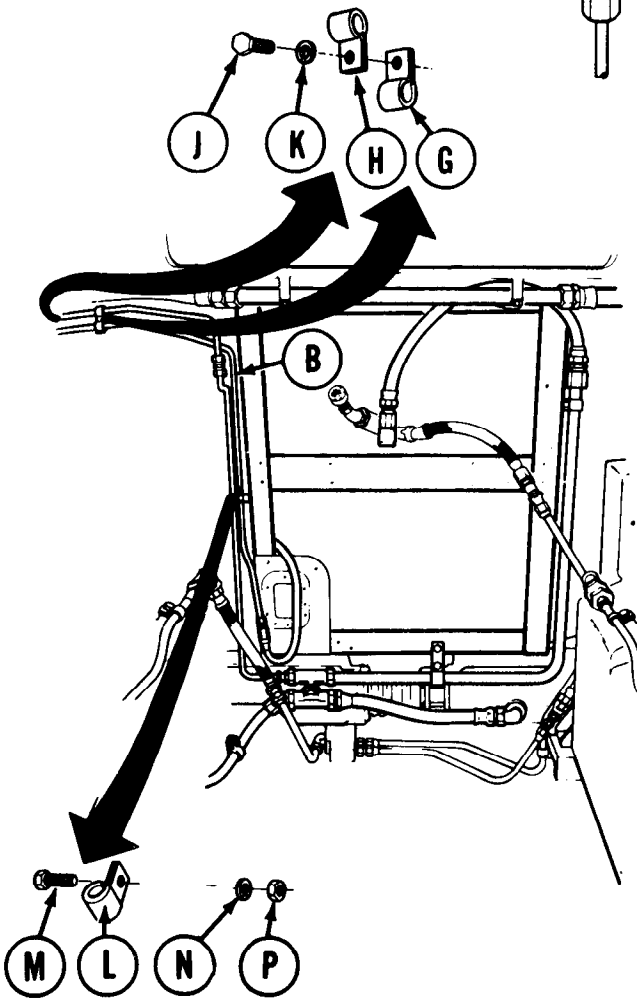
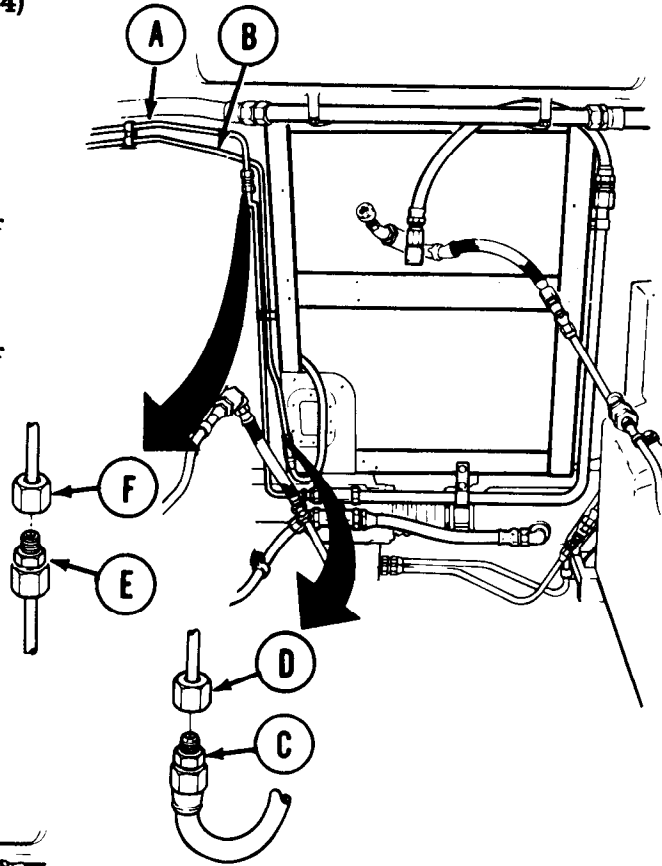

5. Using 7/16 inch socket, install two screws (J) and lockwashers (K) securing four clamps (G) and (H).
6. Position clamp (L) on tube assembly (B).
7. Using 7/16 inch socket and 7/16 inch wrench, install screw (M), lockwasher (N), and nut (P) securing clamp (L).

Go on to Sheet 4

TA108359

FUEL LINES REPLACEMENT - PRIMER PUMP LINES (INLET) (OUTLET) FROM BULKHEAD TO ENGINE COMPARTMENT (Sheet 4 of 4)

8. Using 11/16 inch wrench to hold nipple (Q), use 5/8 inch wrench to connect tube assembly nut (R) to nipple (Q).
9. Using 11/16 inch wrench to hold nipple (S), use 9/16 inch wrench to connect tube assembly nut (T) to nipple (S).
10. Install bulkhead access cover (TM 5-5420-226-20).
11. Install left fuel tank (page 4-32).

End of Task

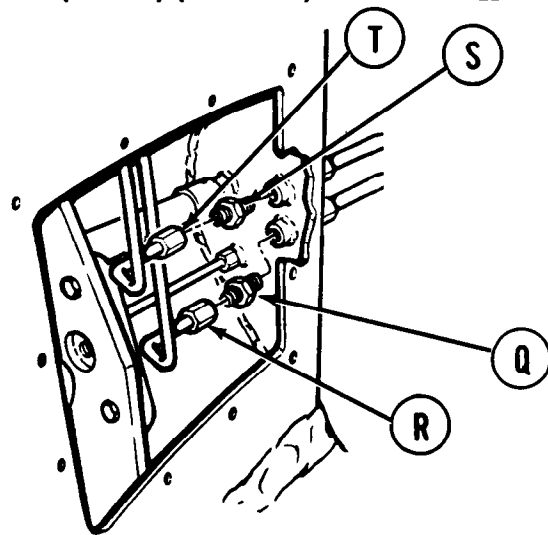

TA108360

ACCELERATOR CONTROL LINKAGE ASSEMBLY REPLACEMENT (Sheet 1 of 6)

PROCEDURE INDEX

PROCEDURE	PAGE
Removal	4-80
Cleaning and Inspection	4-82
Installation	4-83

TOOLS: Long round nosed pliers
 9/16 in. socket with 1/2 in. drive
 Ratchet with 1/2 in. drive
 7/16 in. combination box and open end wrench
 Flat-tip screwdriver
 1/2 in. combination box and open end wrench
 5 in. extension with 1/2 in. drive
 9/16 in. combination box and open end wrench

SUPPLIES: Rags
 Cotter pin
 Dry cleaning solvent (Item 12, Appendix B)

REFERENCE: TM 5-5420-226-10
 TM 5-5420-226-20

PRELIMINARY PROCEDURES: Remove powerplant (TM 5-5420-226-20)
 Remove torsion bars 5L and 5R (TM 5-5420-226-20)
 Remove floor access plate under operator's seat
 (TM 5-5420-226-20)

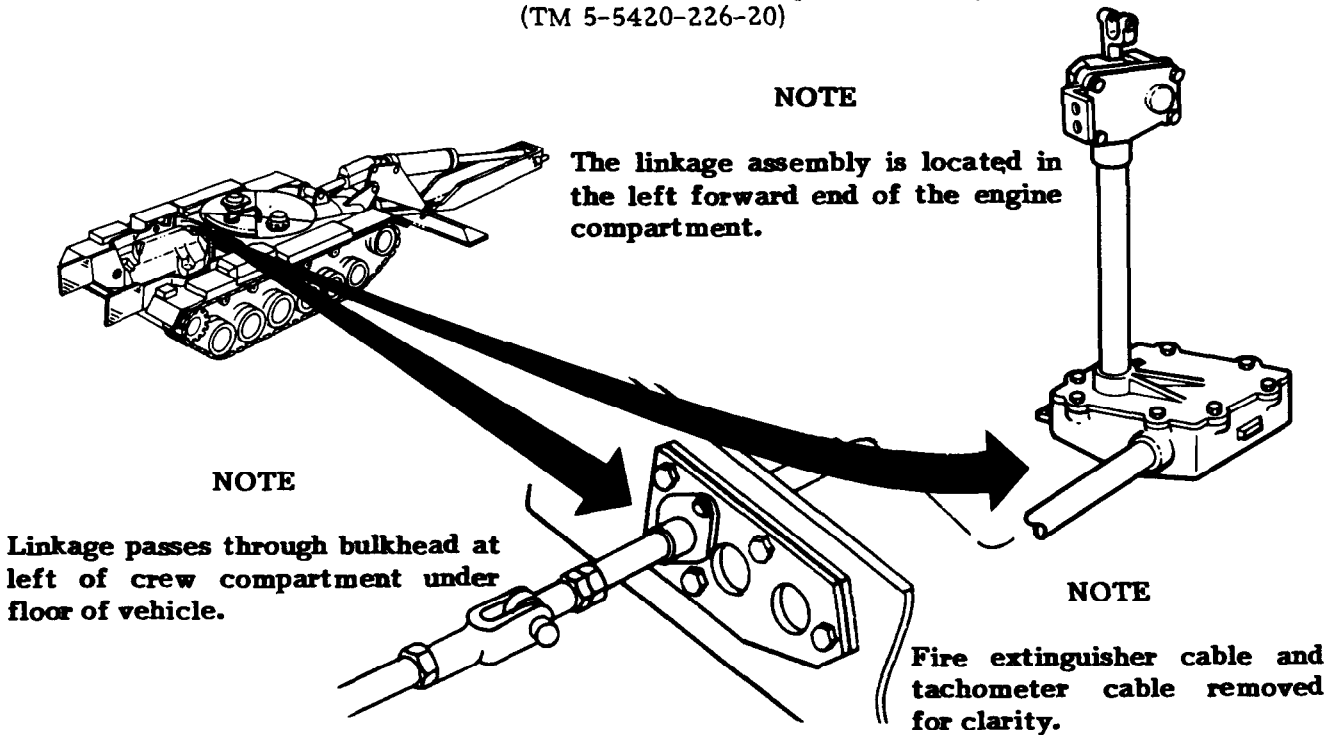

Go on to Sheet 2

TA108361

ACCELERATOR CONTROL LINKAGE ASSEMBLY REPLACEMENT (Sheet 2 of 6)**REMOVAL:****NOTE**

Steps 1 thru 6 are performed inside crew compartment at the rear left bulkhead near floor of vehicle.

1. Using pliers, remove cotter pin (A) from straight pin (B). Throw cotter pin away.
2. Using pliers, remove straight pin (B) from clevis (C).
3. While holding tube (D) clear of clevis (C), use 7/16 inch wrench to hold rod end (E) and 1/2 inch wrench on jamnut (F) to loosen jamnut and remove rod end (E).
4. Using 1/2 inch wrench, remove jamnut (F).

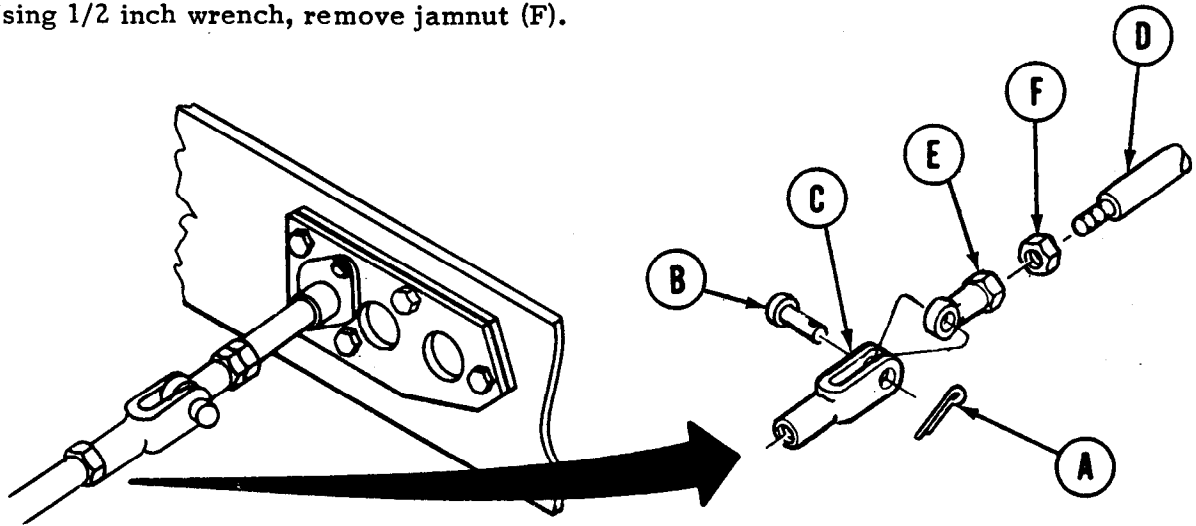

5. Using 9/16 inch socket and ratchet, remove two nuts (G) and two lockwashers (H) securing flange (J).

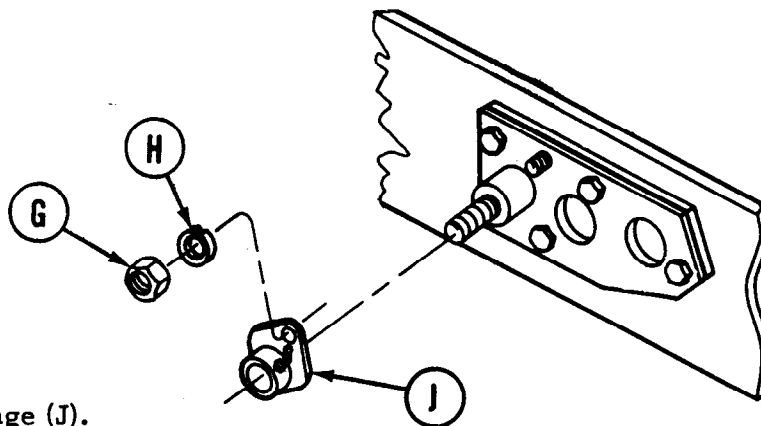

6. Remove flange (J).

Go on to Sheet 3

TA108362

ACCELERATOR CONTROL LINKAGE ASSEMBLY REPLACEMENT (Sheet 3 of 6)

7. Using 9/16 inch socket, remove two screws (K), lockwashers (L), and plate (M) from base of accelerator control linkage assembly (N).
8. Using 9/16 inch socket, remove two screws (P), lockwashers (Q), and flat washers (R) from upper end of accelerator control linkage assembly (N).
9. Using both hands, slide entire accelerator control linkage assembly toward rear of vehicle until tube assembly is free of bulkhead.

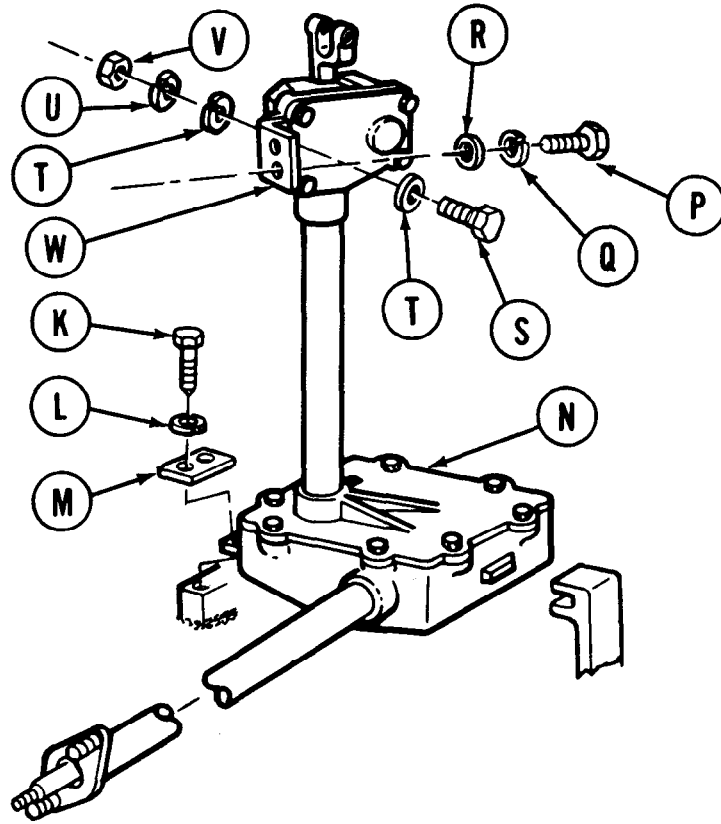

10. Using both hands, lift and remove accelerator control linkage assembly (N) from engine compartment.
11. Using 9/16 inch socket and 9/16 inch wrench, remove two screws (S), four flat washers (T), two lockwashers (U), and two nuts (V) securing bracket (W) to accelerator control linkage assembly (N). Remove and retain bracket (W) for installation onto replacement accelerator control linkage assembly.

CLEANING AND INSPECTION:

1. Using rags and dry cleaning solvent (Item 12, Appendix B), clean entire housing assembly.
2. Inspect for cracks, damage, and wear. Replace if required.

Go on to Sheet 4

TA108363

ACCELERATOR CONTROL LINKAGE ASSEMBLY REPLACEMENT (Sheet 4 of 6)

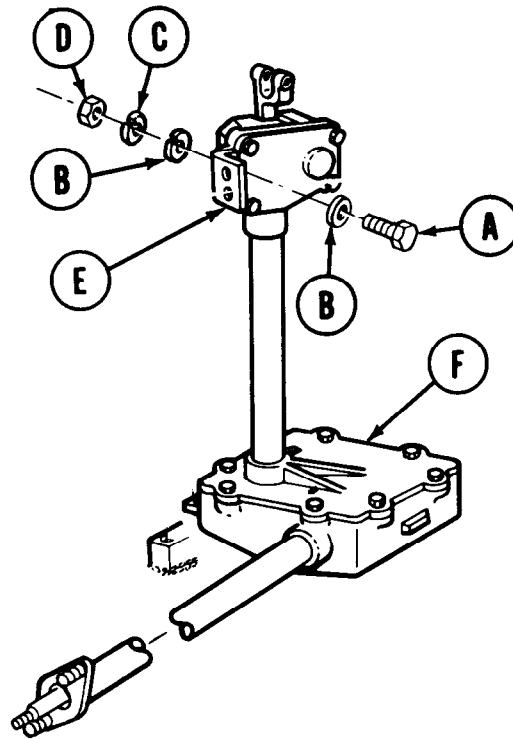

INSTALLATION:

1. Using 9/16 inch socket and 9/16 inch wrench, install two screws (A), four flat washers (B), two lockwashers (C), and two nuts (D) to secure bracket (E) to accelerator control linkage assembly (F).
2. Using both hands, lift accelerator control linkage assembly (F) into engine compartment.
3. Using both hands, position accelerator control linkage assembly (F) to rear wall of bulkhead.
4. Aline tube assembly of accelerator control linkage assembly (F) with access hole in bulkhead.
5. Push accelerator control linkage assembly (F) forward until tube assembly studs pass through access hole in bulkhead.

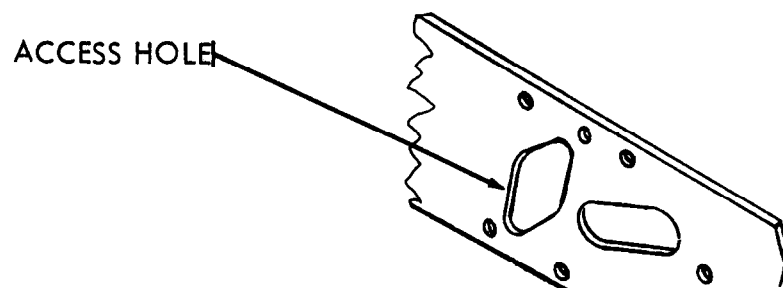

Go on to Sheet 5

TA108364

ACCELERATOR CONTROL LINKAGE ASSEMBLY REPLACEMENT (Sheet 5 of 6)

6. Aline two holes in base of accelerator control linkage assembly (F) with two lower mounting holes on floor of engine compartment.

NOTE

Make sure that tab on side of housing slides between two guides welded to floor of hull.

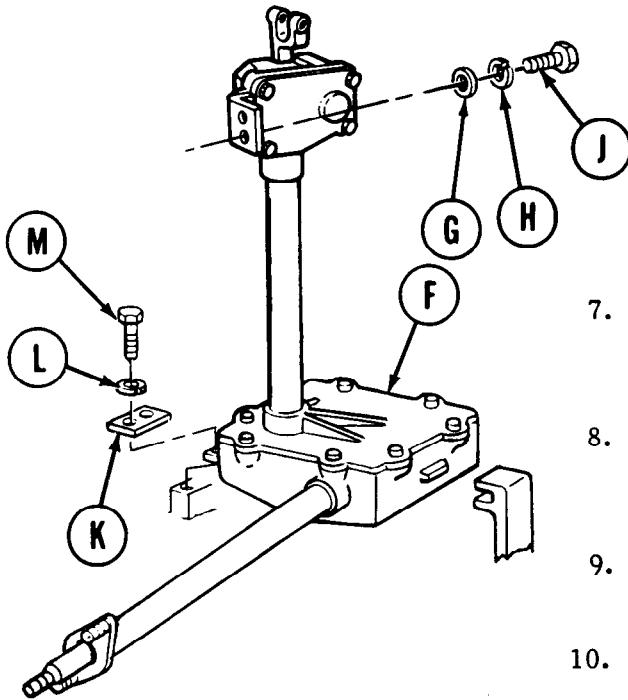

7. Aline two holes on upper end of accelerator control linkage assembly (F) with two holes in bracket attached to bulkhead.
8. Using 9/16 inch socket, install two flat washers (G), lockwashers (H), and screws (J).
9. Aline holes in plate (K) with holes in base of accelerator control linkage assembly (F).
10. Using 9/16 inch socket, install two lockwashers (L) and screws (M) through plate (K) and accelerator control linkage assembly (F).

Go on to Sheet 6

TA108365

ACCELERATOR CONTROL LINKAGE ASSEMBLY REPLACEMENT (Sheet 6 of 6)

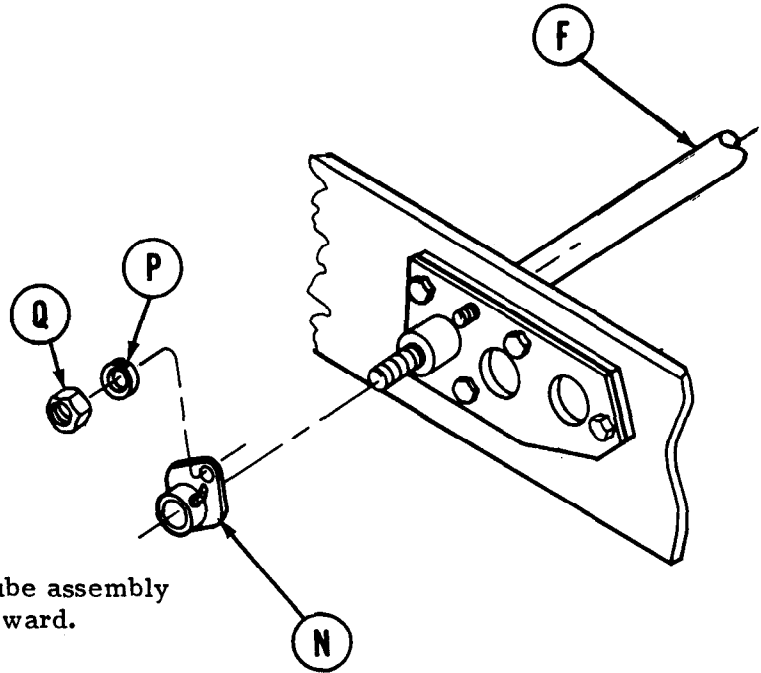

11. Aline flange (N) over studs of tube assembly (F) with grease fitting facing upward.
12. Using 9/16 inch socket, install two lockwashers (P) and nuts (Q) on studs.
13. Using 1/2 inch wrench, install jamnut (R) on tube (S).
14. Using 7/16 inch wrench, install rod end (T) on tube (S).
15. Continue to tighten rod end (T) on tube (S) until hole in clevis (U) alines with hole in rod end (T).
16. Using pliers, install straight pin (V).
17. Using pliers, install new cotter pin (W).
18. Using 1/2 inch wrench, tighten nut (R) against rod end (T).
19. Install powerplant (TM 5-5420-226-20).
20. Install torsion bars 5L and 5R (TM 5-5420-226-20).
21. Install floor access plate under operator's seat (TM 5-5420-226-20).

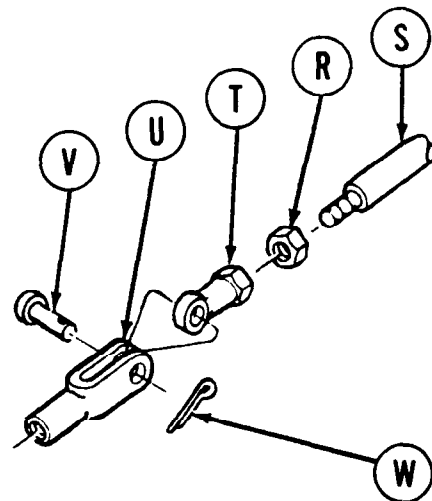

End of Task

TA108366

ACCELERATOR CONTROL LINKAGE ASSEMBLY REPAIR (Sheet 1 of 13)

PROCEDURE INDEX

PROCEDURE	PAGE
Disassembly	4-86
Cleaning	4-91
Inspection and Repair	4-91
Assembly	4-94

- TOOLS:**
- | | |
|--|-----------------------------------|
| 7/16 in. combination box and open end wrench | 1/2 in. socket with 1/2 in. drive |
| 9/16 in. combination box and open end wrench | Slip joint pliers |
| 1/2 in. combination box and open end wrench | Deburring stone |
| 3/16 in. socket head screw key | Vise |
| 5/32 in. drive pin punch | 3/8 in. drive pin punch |
| Hammer | Scribe |
| Flat-tip screwdriver | Pry bar |
| Ratchet with 1/2 in. drive | |

- SUPPLIES:**
- Rags
 - Seal (11610579)
 - Gasket (11610571)
 - Preformed packing (MS28775-115)
 - Dry cleaning solvent (Item 12, Appendix B)
 - Woodruff key (MS335756-5)
 - Channel brush (Item 2, Appendix B)

PRELIMINARY PROCEDURE: Remove accelerator control linkage assembly (page 4-80)

ACCELERATOR CONTROL LINKAGE ASSEMBLY REPAIR (Sheet 2 of 13)**DISASSEMBLY:**

- Using 1/2 inch wrench, remove four screws and lockwashers (A) holding cover (B) to riser housing (C).

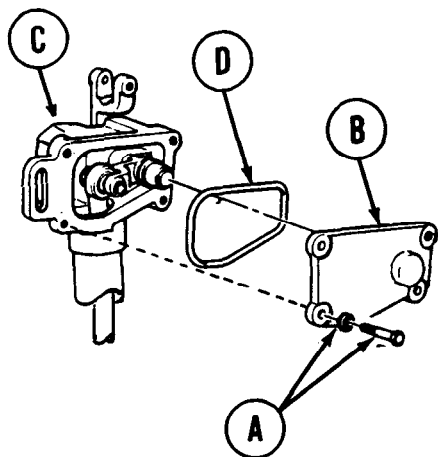

- Using pinch bar, pull cover (B) from riser housing (C).
- Pull away seal (D). Discard seal (D).

- Using 7/16 inch wrench, remove bolt (E) holding connecting link (F) to lever assembly (G).
- Move connecting link (F) away from lever assembly (G).

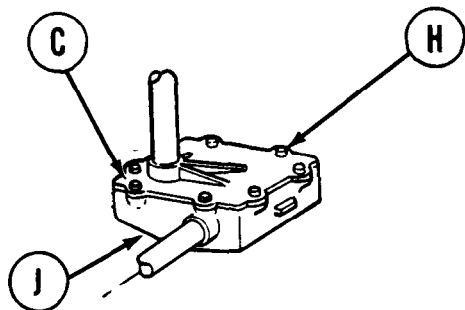
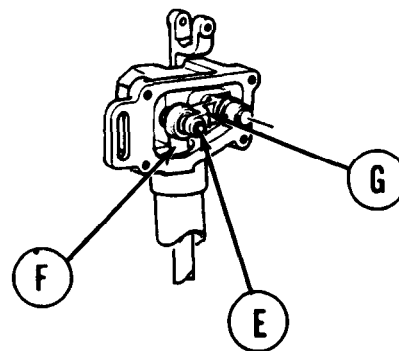

- Using 1/2 inch wrench, remove seven screws and lockwashers (H) holding riser housing (C) to control housing assembly (J).

Go on to Sheet 3

TA108368

ACCELERATOR CONTROL LINKAGE ASSEMBLY REPAIR (Sheet 3 of 13)

7. Using pry bar, pull riser housing (C) from control housing assembly (J).
8. Pull away gasket (K). Discard gasket (K).
9. Using hammer and drive pin punch, remove pin (L) from lever (M).

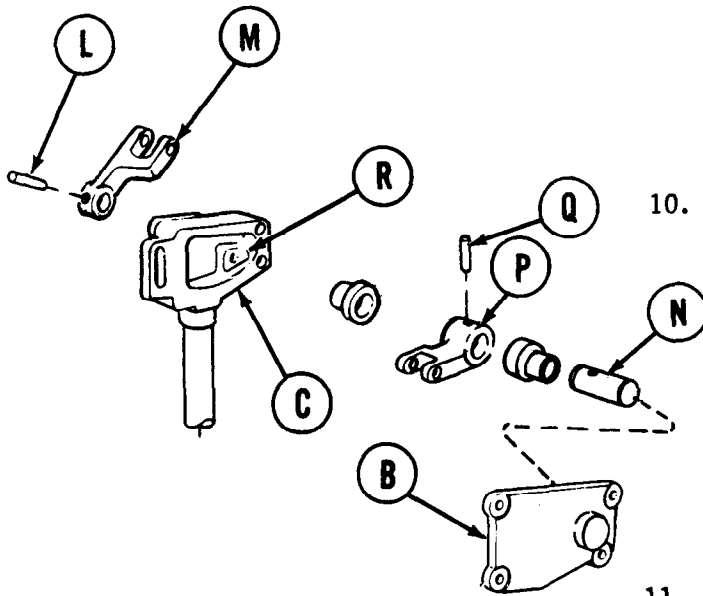
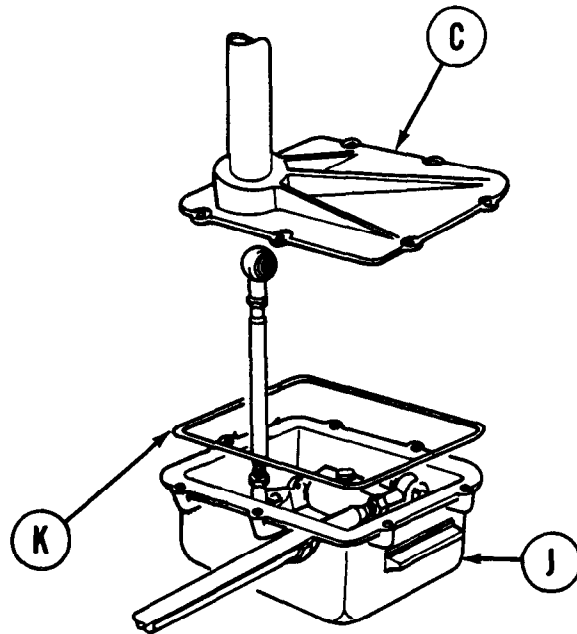

10. Using pry bar, pry lever (M) from shaft (N).

CAUTION

Do not remove bearings (R) from cover (B) or housing (C) unless ID (inside diameter) is beyond wear limits (page 4-92).

11. Pull shaft (N), lever (P), and pin (Q) from riser housing (C) as an assembly.

12. Using hammer and drive pin punch, remove pin (Q) from shaft (N).
13. Slide lever (P) off of shaft (N).

Go on to Sheet 4

TA108369

ACCELERATOR CONTROL LINKAGE ASSEMBLY REPAIR (Sheet 4 of 13)

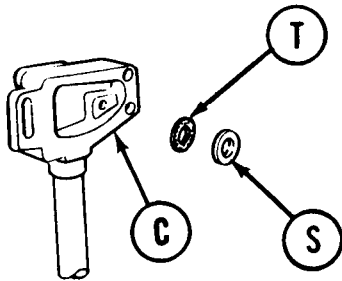

14. If bearing (R) has been removed from housing (C), remove washer (S) and preformed packing (T) from riser housing (C). Throw preformed packing (T) away.

15. Using scribe, mark clevis rod end (U) and housing (V) to provide a reference during assembly.
16. Using scribe, mark clevis with shaft (W) and housing (V) to provide a reference during assembly.
17. Using 7/16 inch wrench, remove bolt (X) holding tube assembly (Y) to clevis (U).

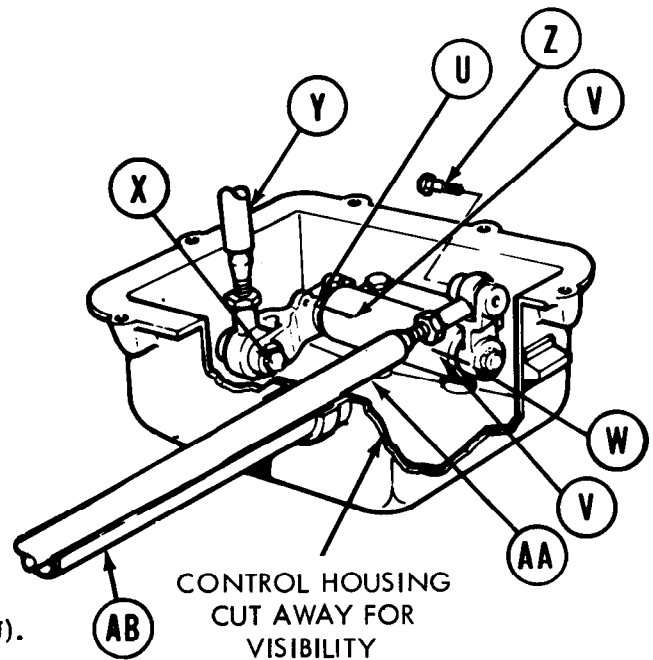

18. Move tube assembly (Y) away from clevis (U).
19. Using 7/16 inch wrench, remove bolt (Z) holding tube assembly (AA) to clevis with shaft (W).
20. Move tube assembly (AA) away from clevis with shaft (W).
21. Pull tube assembly (AA) out of control housing and through shaft (AB).

Go on to Sheet 5

TA108370

ACCELERATOR CONTROL LINKAGE ASSEMBLY REPAIR (Sheet 5 of 13)

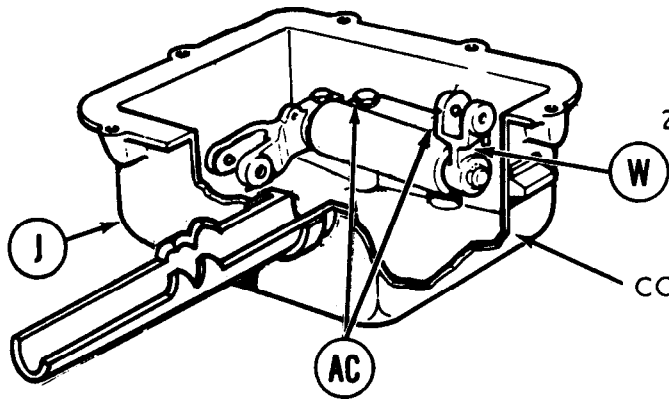

22. Using 1/2 inch socket and ratchet, remove two screws and two lockwashers (AC) holding clevis with shaft (W) to control housing (J).

CONTROL HOUSING
CUT AWAY FOR
VISIBILITY

23. Pull clevis with shaft (W), two bearings (AD), housing (V), and clevis rod end (U) from control housing (J) as an assembly.

24. Using 7/16 inch wrench, remove screw and lockwasher (AE) from clevis (U).

25. Using pry bar, pry clevis (U) from clevis with shaft (W).

26. Using screwdriver, remove woodruff key (AF) from clevis with shaft (W). Throw key away.

27. Pull housing (V) from clevis with shaft (W). Do not try to remove two bearings (AD) from housing (V) unless beyond wear limits (page 4-93).

28. Using socket head screw key, remove drain plug (AG) from control housing (J).

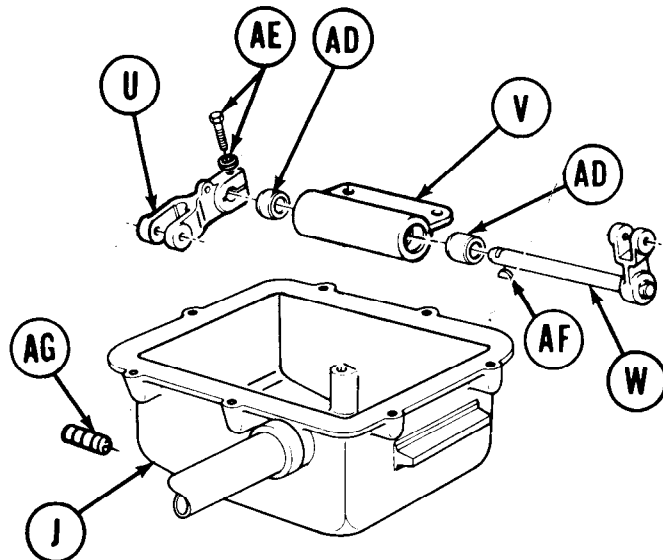

Go on to Sheet 6

TA108371

ACCELERATOR CONTROL LINKAGE ASSEMBLY REPAIR (Sheet 6 of 13)**CLEANING:****NOTE**

When cleaning linkage assembly components, make sure scribe marks made during disassembly are maintained for reference during assembly.

Wearing rubber gloves and using dry cleaning solvent (Item 12, Appendix B), brush, and rags, clean all linkage assembly components.

INSPECTION AND REPAIR:

1. Check all linkage assembly bushing-type bearings.
2. Check and repair all linkage assembly cast parts and mechanical surfaces.
3. Check and repair all linkage assembly threaded parts.
4. Visually check all linkage assembly tubes for distortion or bends. Replace any defective tube.
5. Visually check all linkage assembly shafts and levers for elongated or cracked pin holes. Replace any defective part.
6. Check all linkage assembly rod end bearings for free movement, nicks, and burrs. Replace any rod end with nicks or burrs which cannot be removed with a fine stone, or if free movement is impaired.

Go on to Sheet 7

ACCELERATOR CONTROL LINKAGE ASSEMBLY REPAIR (Sheet 7 of 13)

7. Check linkage assembly components for wear as specified in the following tables. Replace all components which do not meet wear limits. Bearings may be removed using hammer and drift pin or puller. Use vise to install new bearings.

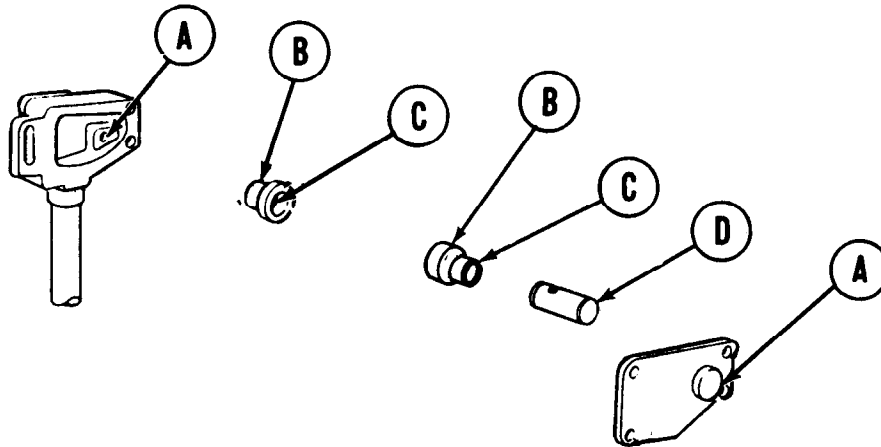

ACCELERATOR LINKAGE WEAR LIMITS

Reference Letter	Point of Measurement	Size and fit of New Parts in.	Wear Limits in.
A	ID of bore in cover & housing	0.875 to 0.876	N/A
B	OD of bearings	0.876 to 0.878	N/A
A-B	Fit of bearing in cover & housing	0.000 to 0.003T	*
C	ID of bearings	0.626 to 0.627	0.632
D	OD of shaft	0.618 to 0.620	*
C-D	Fit of shaft in bearings	0.006L to 0.009L	0.014L

An asterisk (*) in the wear limits column indicates part should be replaced when worn beyond limits given in size and fit of new parts column.

An L following a dimension indicates loose fit.

A T following a dimension indicates a tight fit.

Go on to Sheet 8

TA108372

ACCELERATOR CONTROL LINKAGE ASSEMBLY REPAIR (Sheet 8 of 13)

ACCELERATOR LINKAGE WEAR LIMITS - Continued

Reference Letter	Point of Measurement	Size and fit of New Parts in.	Wear Limits in.
E	ID of bore in housing	0.875 to 0.876	N/A
F	OD of bearings	0.877 to 0.878	N/A
E-F	Fit of bearing in bore	0.001T to 0.003T	*
G	ID of bearings	0.503 to 0.504	0.509
H	OD of shaft	0.4955 to 0.5005	*
G-H	Fit of shaft in bearings	0.003L to 0.009L	0.014L

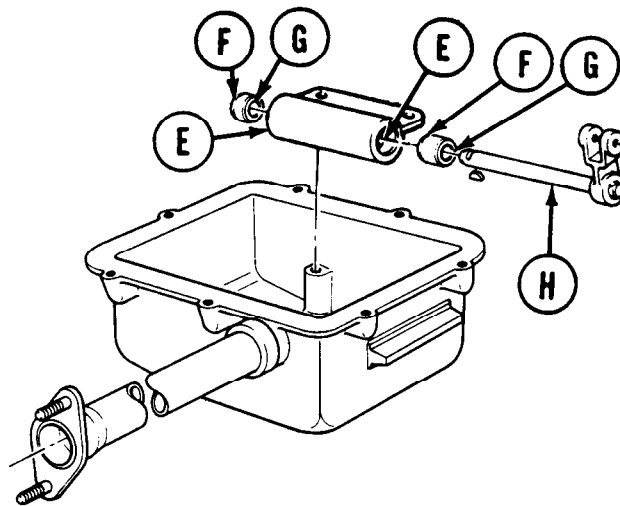

An asterisk (*) in the wear limits column indicates part should be replaced when worn beyond limits given in size and fit of new parts column.

An L following a dimension indicates loose fit.

A T following a dimension indicates a tight fit.

Go on to Sheet 9

TA108373

ACCELERATOR CONTROL LINKAGE ASSEMBLY REPAIR (Sheet 9 of 13)

ASSEMBLY:

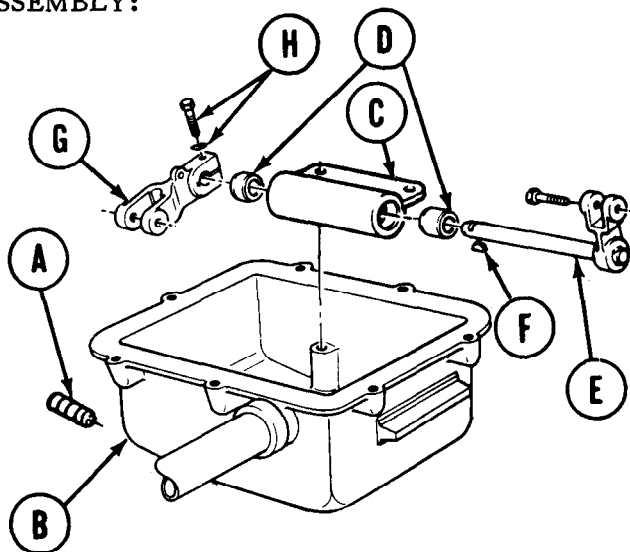

1. Using socket head screw key, install drain plug (A) into control housing (B).

2. Push housing (C) with two bearings (D) onto clevis with shaft (E). Line up scribe marks on housing (C) and clevis with shaft (E).

3. Using hammer, install new woodruff key (F) into clevis with shaft (E).

4. Push clevis rod end (G) onto clevis with shaft (E). Line up reference marks on housing (C) and clevis rod end (G).

5. Line up reference marks on housing (C) and clevis rod end (G) and clevis with shaft (E). Install clevis rod end (G) on clevis with shaft (E).

6. Using 7/16 inch wrench, install screw and lockwasher (H) into clevis rod end (G).

7. Install clevis with shaft (E), two bearings (D), housing (C), and clevis rod end (G) into control housing (B) as a complete lever assembly (J).

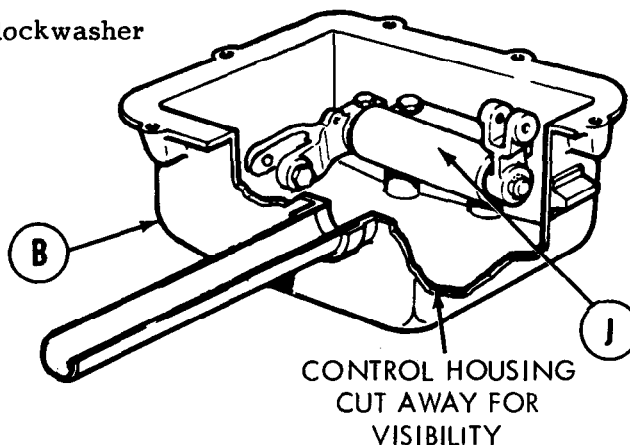

Go on to Sheet 10

TA108374

ACCELERATOR CONTROL LINKAGE ASSEMBLY REPAIR (Sheet 10 of 13)

8. Using 1/2 inch socket and ratchet, install two screws and two lockwashers (K) holding lever assembly (J) to control housing (B).
9. Install tube assembly (L) through shaft (M) into control housing (B).
10. Position tube assembly (L) into mating clevis of lever assembly (J).

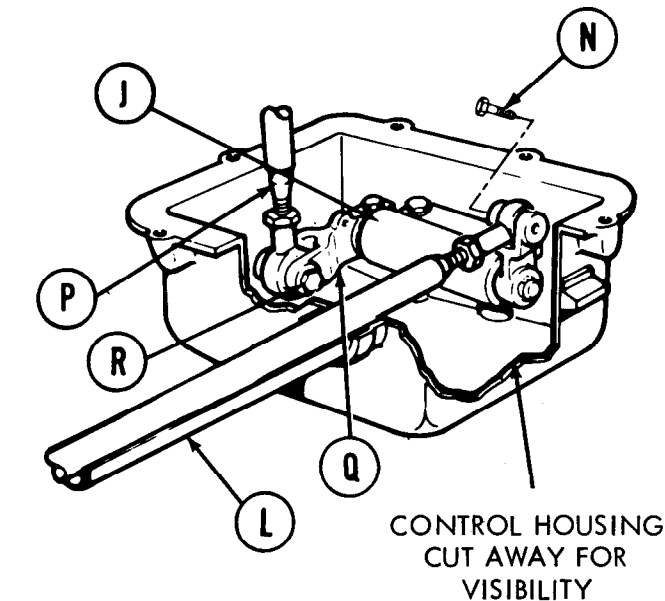
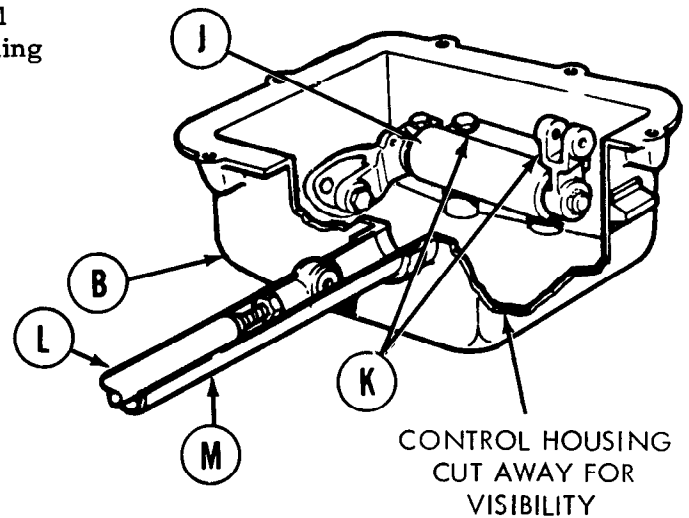

11. Using 7/16 inch wrench, install bolt (N) to hold tube assembly (L) to lever assembly (J).
12. Position connecting link (P) into remaining rod end clevis (Q) of lever assembly (J).

13. Using 7/16 inch wrench, install bolt (R) to hold connecting link (P) to rod end clevis of lever assembly (J).
14. If bearing (S) is being installed, insert new preformed packing (T) and new washer (U) into riser housing (V).

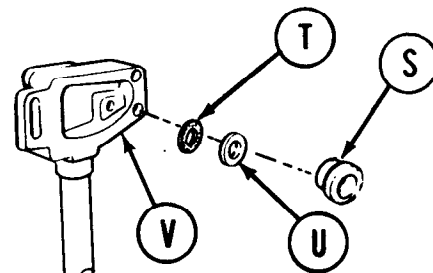

Go on to Sheet 11

TA108375

ACCELERATOR CONTROL LINKAGE ASSEMBLY REPAIR (Sheet 11 of 13)

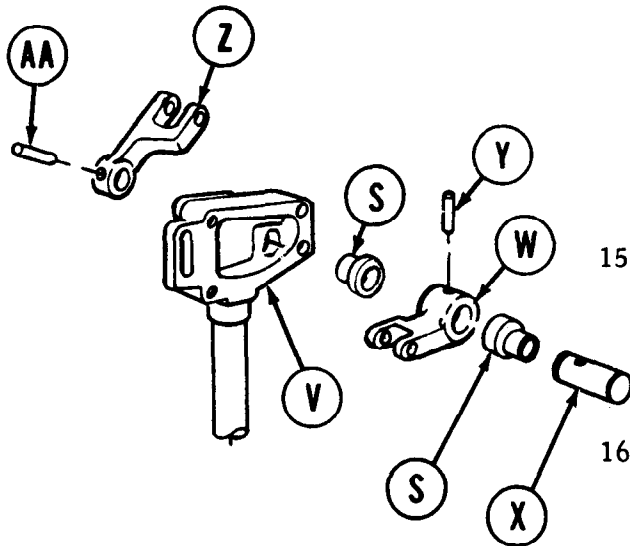

NOTE

If bearings (S) were removed, install in housing (V) with vise.

15. Slide short lever (W) onto shaft (X). Line up pin holes.

16. Insert pin (Y) into lever (W).

17. Using hammer and pin punch, install pin (Y) into lever (W) and shaft (X).

18. Install shaft (X), lever (W), and pin (Y) into riser housing (V) as an assembly.

19. Install long lever (Z) onto shaft (X) until lever and shaft pin holes line up.

20. Insert pin (AA) into long lever (Z).

21. Using hammer and pin punch, install pin (AA) into long lever (Z) and shaft (X).

ACCELERATOR CONTROL LINKAGE ASSEMBLY REPAIR (Sheet 12 of 13)

22. Install new gasket (AB) into groove on bottom of riser housing (U).
23. Slide tube assembly (P) through shaft (AC) and onto control housing (B).
24. Place riser housing (U) with gasket (AB) on control housing assembly (B).

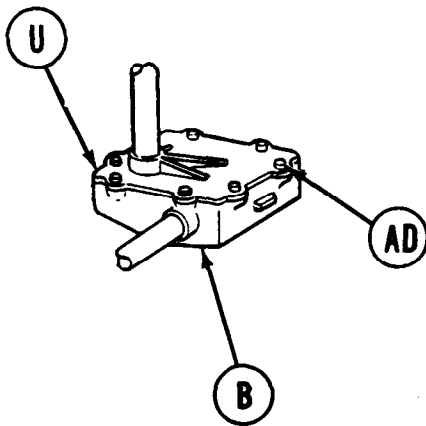
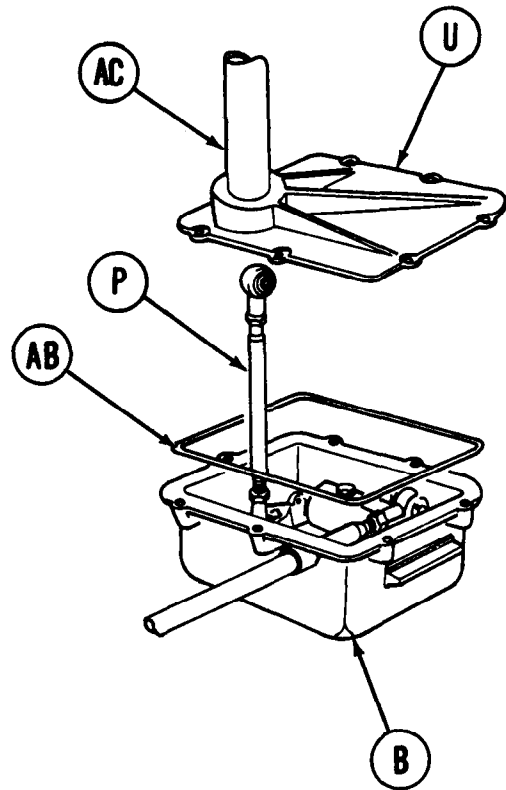

25. Using 1/2 inch wrench, install seven screws and lockwashers (AD) to hold riser housing (U) to control housing assembly (B).

26. Aline tube assembly bearing (AE) within lever (AF).
27. Using 7/16 inch wrench, install screw (AG) to hold tube assembly (P) to lever assembly (AH).

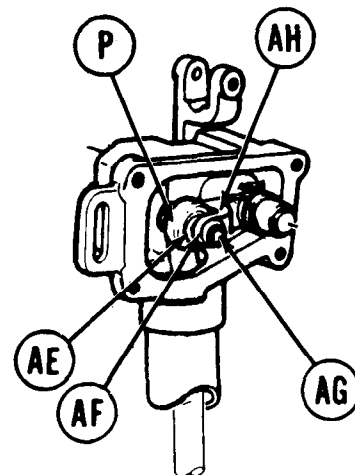

Go on to Sheet 13

TA108377

ACCELERATOR CONTROL LINKAGE ASSEMBLY REPAIR (Sheet 13 of 13)

27. Install new seal (AJ) into groove in cover (AK).

28. Position cover (AK) onto riser housing (U).

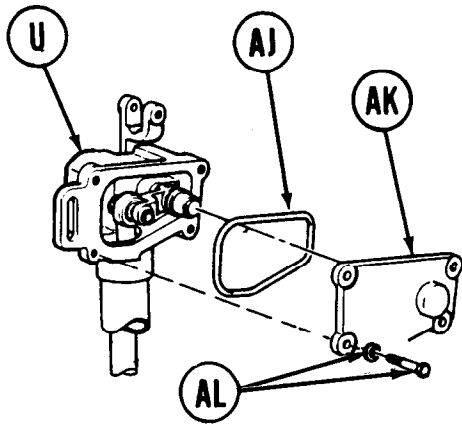

29. Using 1/2 inch wrench, install four screws and lockwashers (AL) to hold cover (AK) to riser housing (U).

30. Make sure tube assembly and accelerator lever operate smoothly when tube assembly is moved within its limits.

31. Install accelerator control linkage assembly into vehicle (page 4-83).

End of Task

TA108378

CHAPTER 5
ELECTRICAL SYSTEM MAINTENANCE

INDEX

Procedure	Page
Bulkhead Cable Disconnect	5-2
Power/Master Control Panel Harness Replacement	5-75
Front Accessory Harness Replacement	5-83

BULKHEAD CABLE DISCONNECT (Sheet 1 of 2)

TOOLS: Spanner wrench
Flat-tip screwdriver

9/16 in. socket with 1/2 in. drive
Ratchet with 1/2 in. drive

REFERENCE: TM 5-5420-226-20

PRELIMINARY PROCEDURES: Remove three ground straps from battery negative terminals (TM 5-5420-226-20)
Remove commander's seat (TM 5-5420-226-20)
Remove right bulkhead access cover (TM 5-5420-226-20)

REMOVAL:

1. Using 9/16 inch socket and ratchet, remove seven screws (A) and lockwashers (B) securing connector cover plate (C) to bulkhead.
2. Pull connector plate cover (C) and its gasket (D) away from bulkhead. Harness assemblies inside bulkhead will come with cover plate (C).

NOTE

To remove either of the two middle connectors on the cover plate, you must first remove either the top or bottom connector, as required, to get a spanner wrench on the desired connector.

3. Using spanner wrench, disconnect and remove connector (E) at back side of cover plate (C).
4. Using flat-tip screwdriver, remove four screws (F) and lockwashers (G) securing corresponding connector (H) and gasket (J) at front side of cover plate (C).

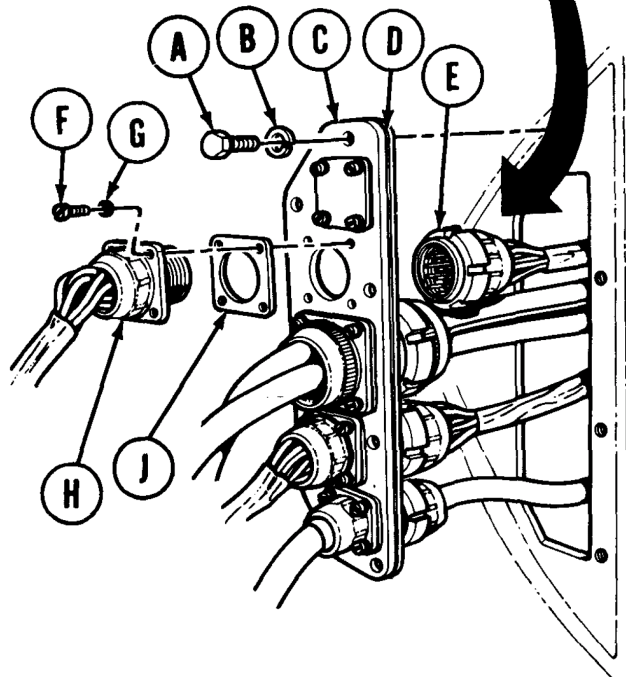
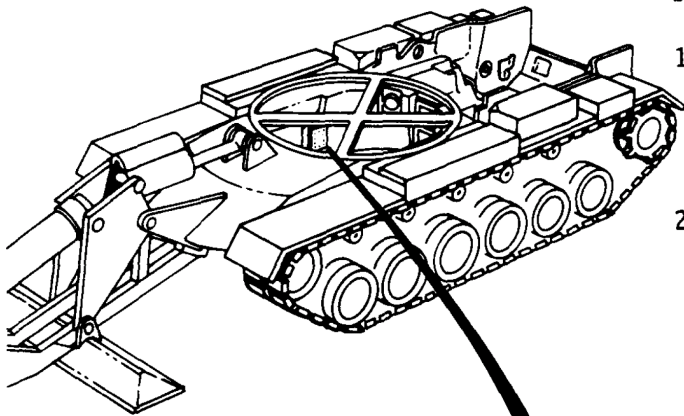

BULKHEAD CABLE DISCONNECT (Sheet 2 of 2)

NOTE

Bulkhead connectors can be installed in one of three ways; top to bottom, bottom to top or center to top or bottom. The instructions below are for installation of the bottom connector first. Installation procedures are the same for all the other connectors.

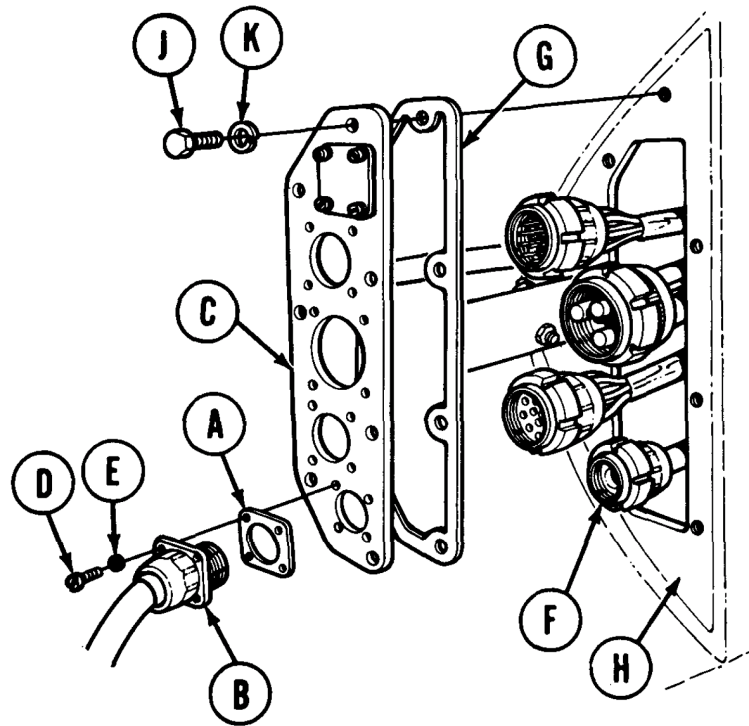

INSTALLATION:

1. Place gasket (A) on connector (B).
2. Make sure keyway inside connector (B) is at top. Place connector (B) and gasket (A) in position on cover plate (C).
3. Using flat-tip screwdriver, install four screws (D) and lockwashers (E) securing connector (B) and gasket (A) to cover plate (C).
4. Using fingers, install connector (F) on connector (B).
5. When connector (F) is finger tight, use spanner wrench to finish tightening.
6. Install succeeding connectors in consecutive order in same manner.
7. After all connectors are installed, place cover plate (C) and gasket (G) in position on bulkhead (H).
8. Using 9/16 inch socket, install seven screws (J) and lockwashers (K) to secure cover plate (C) to bulkhead (H).
9. Install right bulkhead access cover (TM 5-5420-226-20).
10. Install commander's seat (TM 5-5420-226-20).
11. Connect three ground straps at batteries (TM 5-5420-226-20).

End of Task

TA108380

All data on pages 5-4 thru 5-74 deleted.

POWER/MASTER CONTROL PANEL HARNESS REPLACEMENT (Sheet 1 of 8)

PROCEDURE INDEX

PROCEDURE	PAGE
Removal	5-75
Installation	5-79

TOOLS: Spanner wrench
 7/16 in. socket with 1/2 in. drive
 Ratchet with 1/2 in. drive
 15 in. adjustable wrench

SUPPLIES: Silicone compound (Item 10, Appendix B)

REFERENCE: TM 5-5420-226-10
 TM 5-5420-226-20

PRELIMINARY PROCEDURES: Remove three battery ground straps (TM 5-5420-226-20)
 Raise commander's seat (TM 5-5420-226-10)
 Remove commander's periscope stowage box (TM 5-5420-226-20)
 Remove subfloor access cover under commander's seat (TM 5-5420-226-20)
 Remove subfloor access cover under commander's periscope stowage box (TM 5-5420-226-20)
 Remove voltage regulator assembly (TM 5-5420-226-20)

Go on to Sheet 2

TA108452

POWER/MASTER CONTROL PANEL HARNESS REPLACEMENT (Sheet 2 of 8)

REMOVAL:

1. Using spanner wrench, disconnect connector (A) at master relay.
2. Follow branch of harness assembly (B) back along voltage regulator mounting bracket (C).

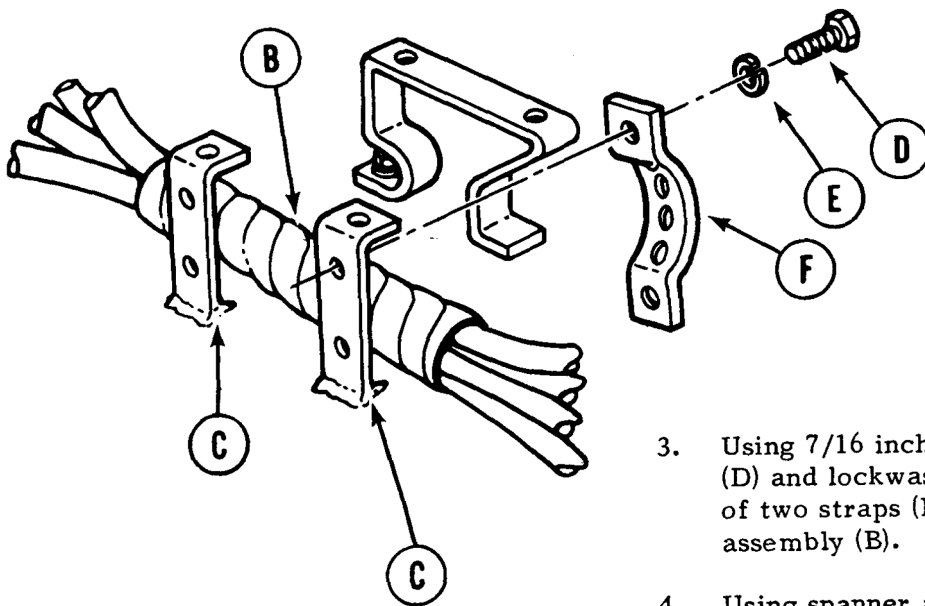
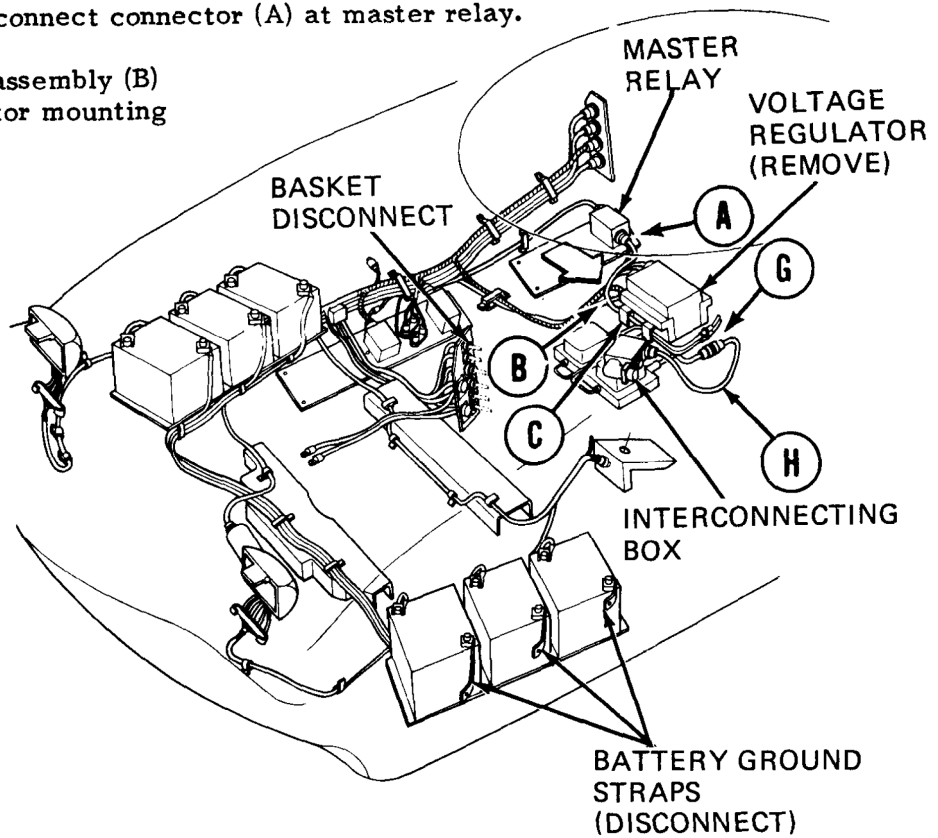

3. Using 7/16 inch socket, remove screws (D) and lockwashers (E) securing tops of two straps (F) that retain harness assembly (B).
4. Using spanner and adjustable wrenches, disconnect connector (G) from interconnecting box cable (H).

Go on to Sheet 3

TA108453

POWER/MASTER CONTROL PANEL HARNESS REPLACEMENT (Sheet 3 of 8)

5. Follow branch of harness assembly (B).
6. Using 7/16 inch socket, remove screw (J) and lockwasher (K) securing one end of strap (L) that retains harness assembly (B) in three places.

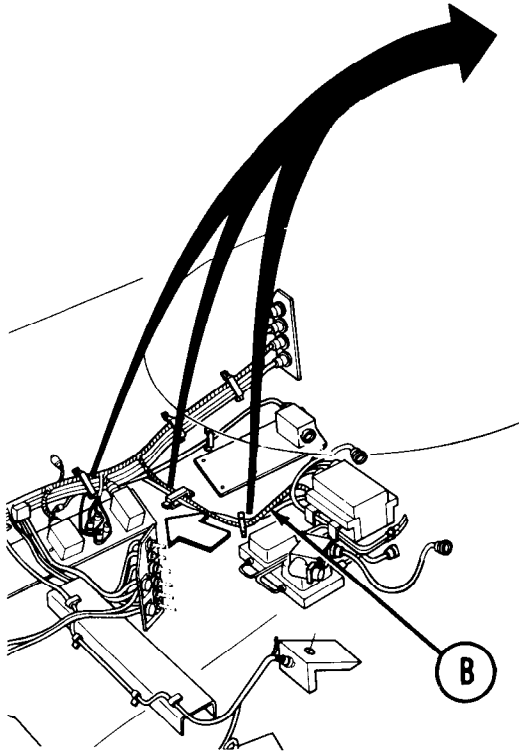
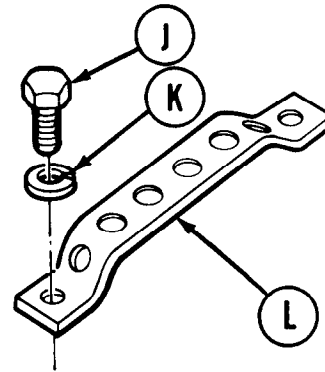

7. Follow branch of harness assembly (B) to find leads (M) and (N),
8. Disconnect lead (M) from lead (P) at blower relay (Q).

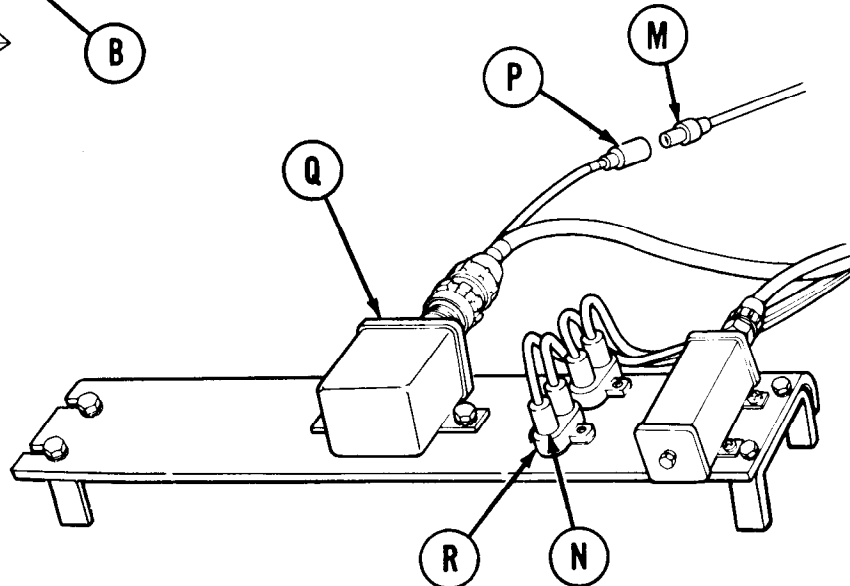

9. Disconnect lead (N) from heater feed circuit breaker (R).

Go on to Sheet 4

TA108454

POWER/MASTER CONTROL PANEL HARNESS REPLACEMENT (Sheet 4 of 8)

10. Follow branch of harness assembly (B) to back side of basket disconnect.

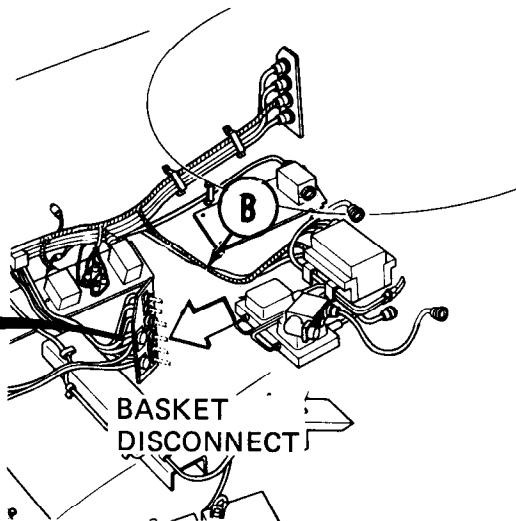
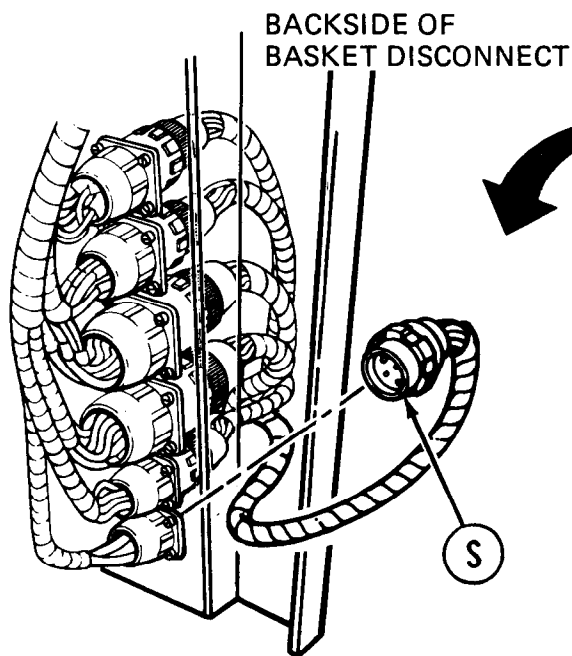

NOTE

The top five connectors must be disconnected before the bottom connector can be disconnected.

11. Using spanner wrench, disconnect bottom connector (S) at back side of basket disconnect.

12. Remove wiring harness assembly (B) from vehicle.

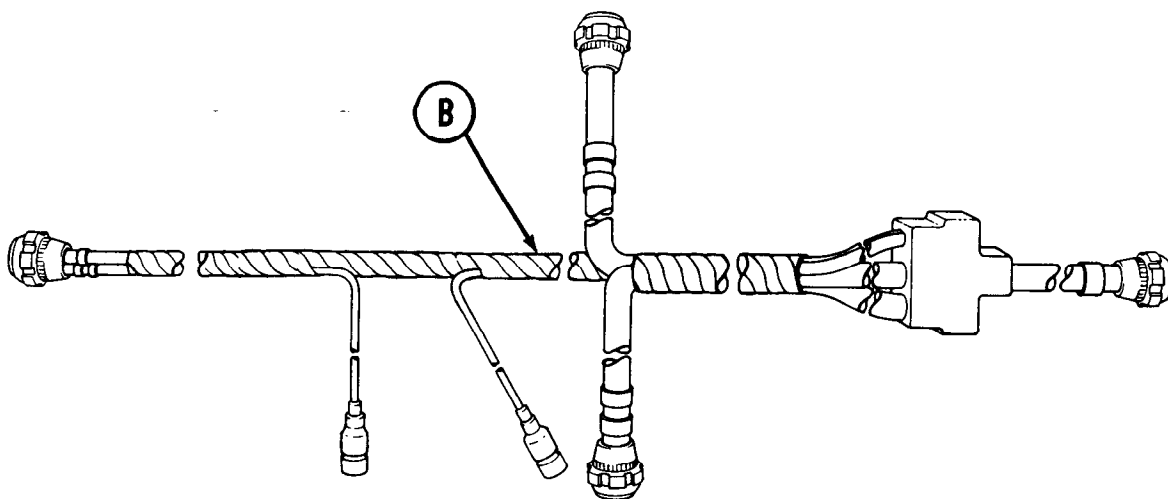

Go on to Sheet 5

TA108455

POWER/MASTER CONTROL PANEL HARNESS REPLACEMENT (Sheet 5 of 8)

INSTALLATION:

NOTE

All harness connectors have metal tags identifying the circuit(s) to which they belong.

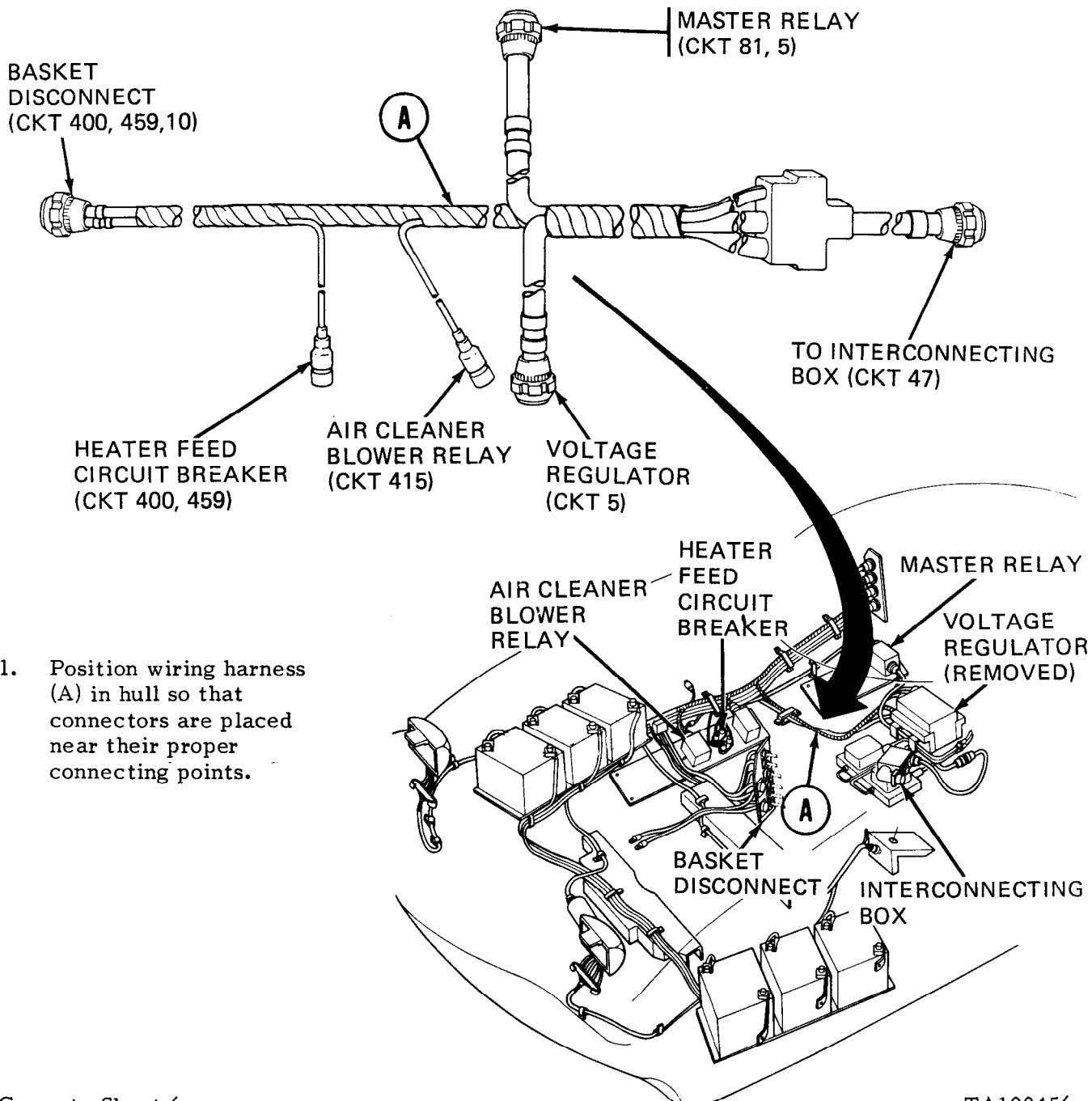

1. Position wiring harness (A) in hull so that connectors are placed near their proper connecting points.

Go on to Sheet 6

TA108456

POWER/MASTER CONTROL PANEL HARNESS REPLACEMENT (Sheet 6 of 8)

2. Using spanner wrench, install connector (B) (CKT 81,5) at master relay.
3. Follow branch of harness assembly (A) back along voltage regulator mounting brackets.

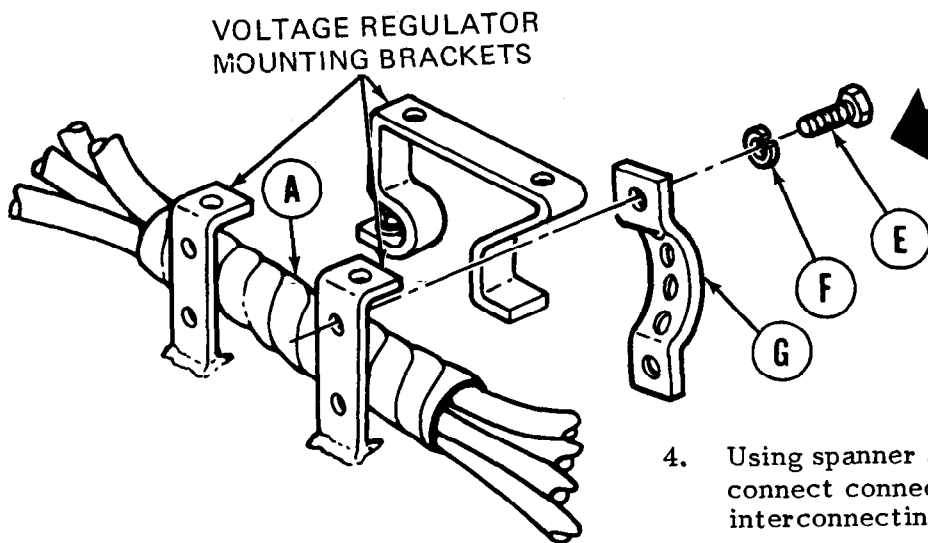
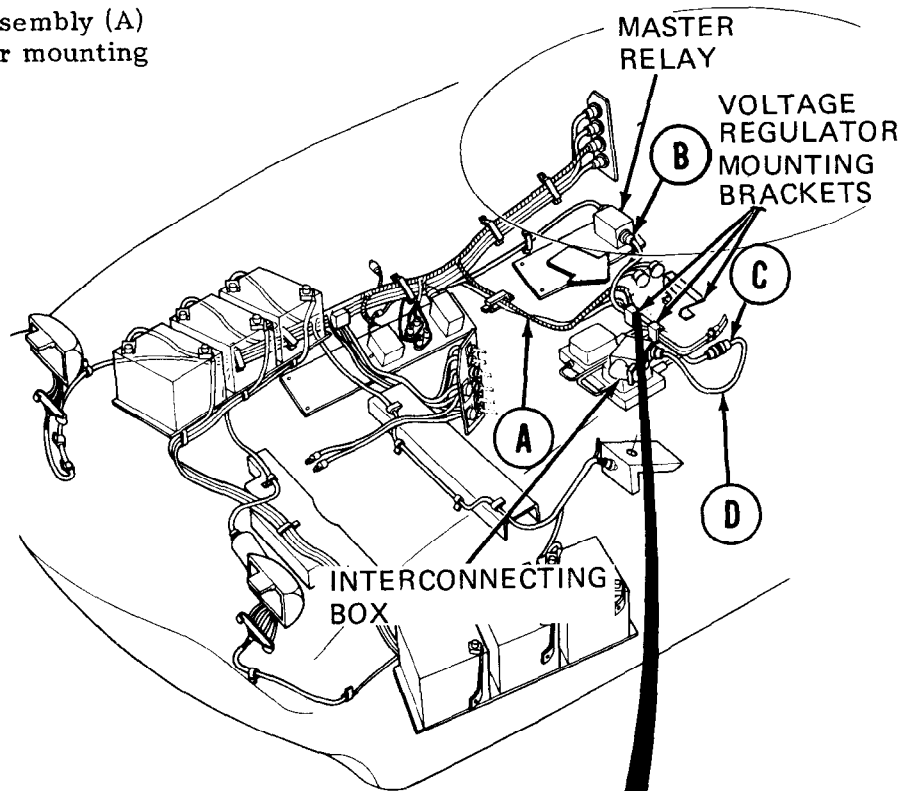

4. Using spanner and adjustable wrenches, connect connector (C) (CKT 47) to interconnecting box cable (D).
5. Using 7/16 inch socket, install two screws (E) and lockwashers (F) securing two straps (G) that retain harness assembly (A) to voltage regulator mounting bracket.

Go on to Sheet 7

TA108457

POWER/MASTER CONTROL PANEL HARNESS REPLACEMENT (Sheet 7 of 8)

6. Follow branch of harness assembly (A).

7. Using 7/16 inch socket, install screw (H) and lockwasher (J) securing strap (K) that retains harness assembly (A) in three places.

8. Follow branch of harness assembly (A) to find leads (L) and (M).

9. Connect lead (L) (CKT 415) to lead (N) at blower relay (P). Lubricate rubber-to-rubber contact surfaces with silicone compound.

10. Connect lead (M) (CKT 459) to heater feed circuit breaker (Q).

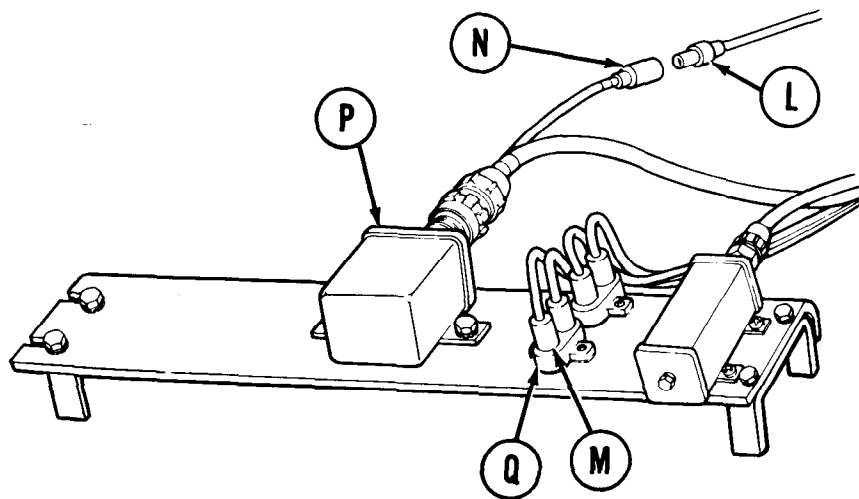
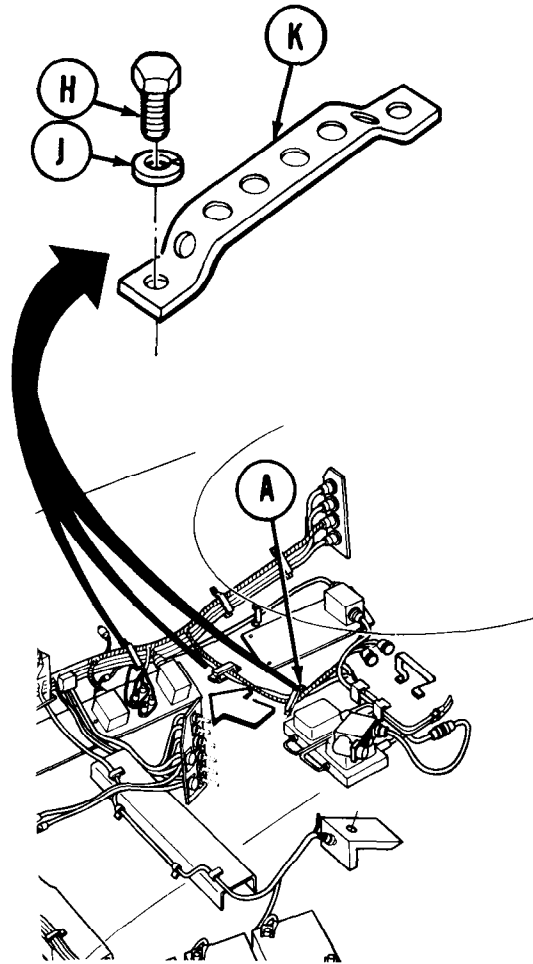

Go on to Sheet 8

TA108458

POWER/MASTER CONTROL PANEL HARNESS REPLACEMENT (Sheet 8 of 8)

11. Follow branch of harness assembly (A) to back side of basket disconnect.
12. Using spanner wrench, connect bottom connector (R) (CKT 400,459,10) at back side of basket disconnect.
13. Install voltage regulator assembly (TM 5-5420-226-20).
14. Install subfloor access cover under commander's periscope stowage box (TM 5-5420-226-20).

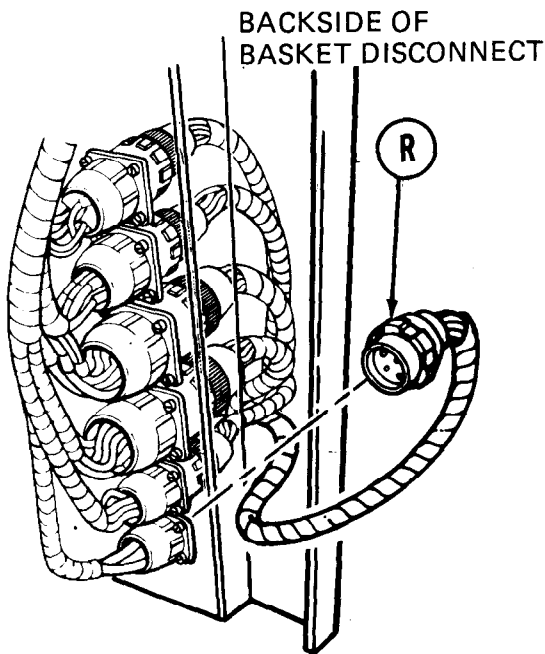
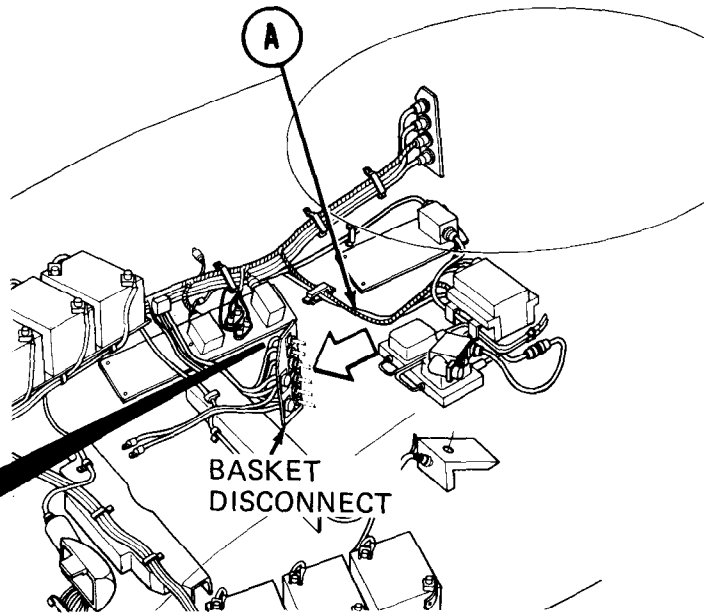

15. Install commander's periscope stowage box (TM 5-5420-226-20).
16. Install subfloor access cover under commander's seat (TM 5-5420-226-20).
17. Install three battery ground straps (TM 5-5420-226-20).

End of Task

TA108459

FRONT ACCESSORY HARNESS REPLACEMENT (Sheet 1 of 14)

PROCEDURE INDEX

PROCEDURE	PAGE
Removal	5-83
Installation	5-90

TOOLS: Spanner wrench
 7/16 in. socket with 1/2 in. drive
 Ratchet with 1/2 in. drive
 1-1/8 in. open end wrench
 7/8 in. open end wrench
 5/8 in. open end wrench
 7/16 in. combination box and open end wrench
 12 in. adjustable wrench
 9/16 in. socket with 1/2 in. drive

SUPPLIES: Silicone compound (Item 10, Appendix B)

REFERENCES: TM 5-5420-226-10
 TM 5-5420-226-20

PRELIMINARY PROCEDURES: Disconnect ground straps at batteries (TM 5-5420-226-20)
 Remove access cover under commander's seat (TM 5-5420-226-20)
 Remove commander's periscope stowage box (TM 5-5420-226-20)
 Remove access cover under commander's periscope stowage box (TM 5-5420-226-20)

REMOVAL:

1. Disconnect two electrical connectors (A) from fixed fire extinguisher release handle (B) located to right and forward of driver's steering control handles (C).

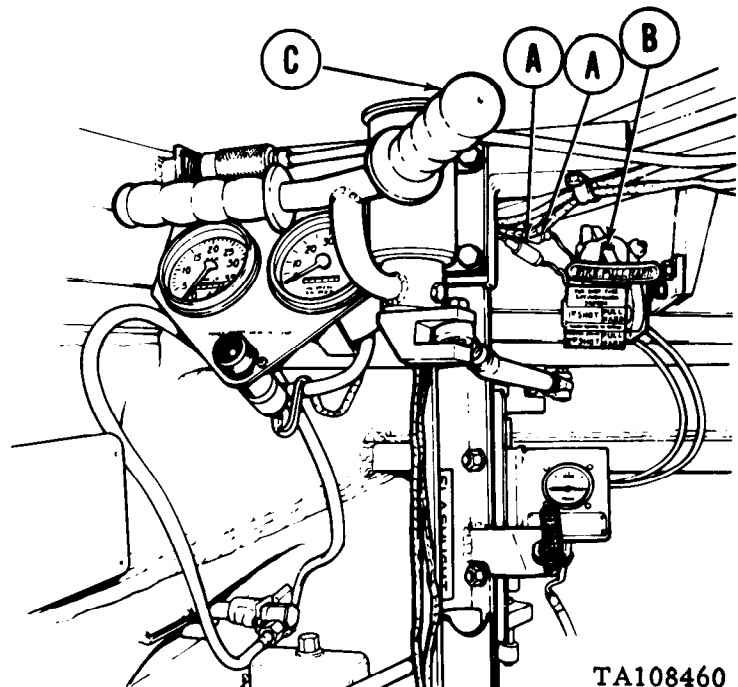

Go on to Sheet 2

TA108460

FRONT ACCESSORY HARNESS REPLACEMENT (Sheet 2 of 14)

2. Follow wire harness (D) to two cushion clamps (E) securing harness to vertical post (F) located to left and forward of driver's seat.
3. Using 7/16 inch socket and ratchet, remove screws (G), lockwashers (H) and clamps (E).
4. Using spanner wrench, loosen spanner nut (J) at dimmer switch connector (K). Disconnect connector (K).

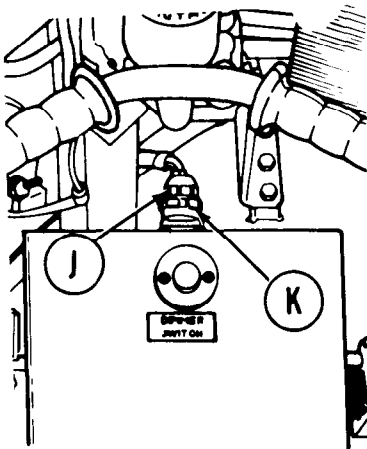
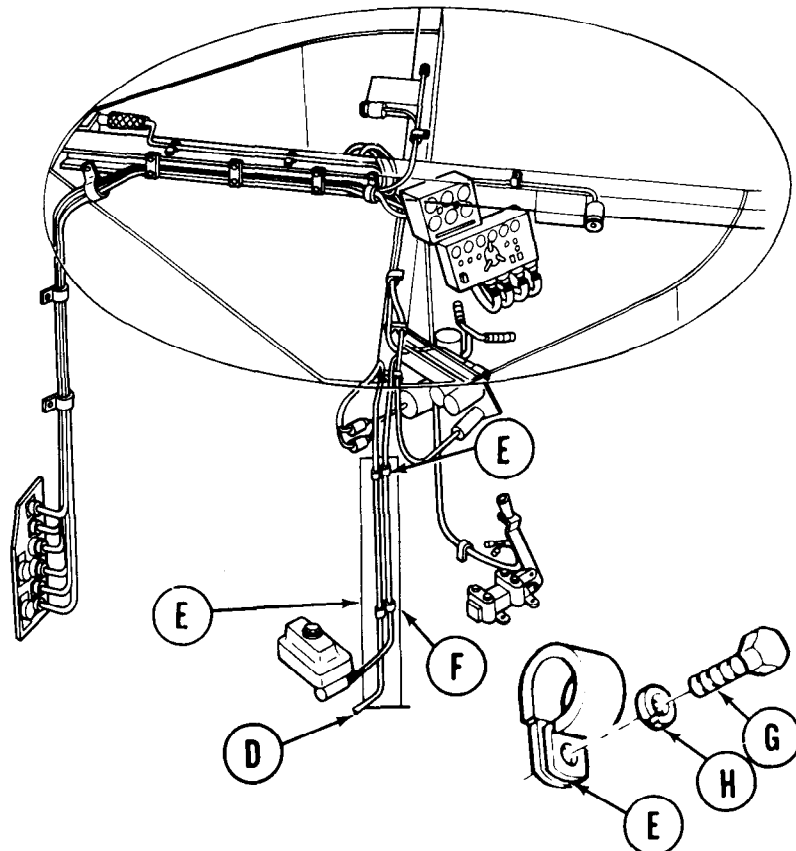

5. Follow harness assembly (D) to left front of vehicle to three clamps (L), located along bottom of battery holding bracket.
6. Using 7/16 inch socket, remove screws (M), lockwashers (N), and clamps (L).

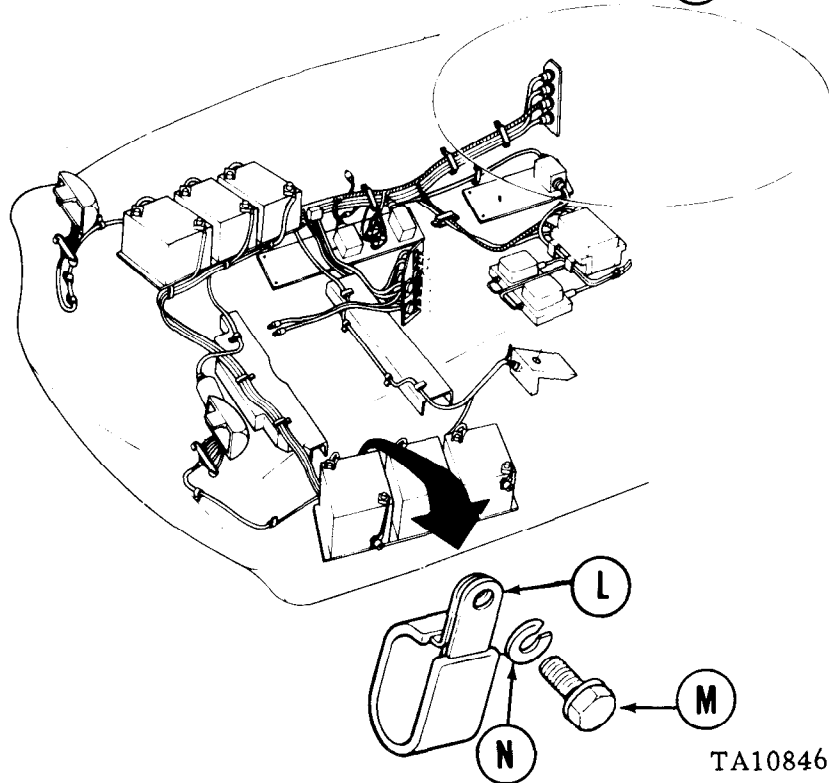

Go on to Sheet 3

TA108461

FRONT ACCESSORY HARNESS REPLACEMENT (Sheet 3 of 14)

7. Follow wiring harness assembly (D) to two cushion clamps (P), located between left battery holding bracket and left headlight (Q).

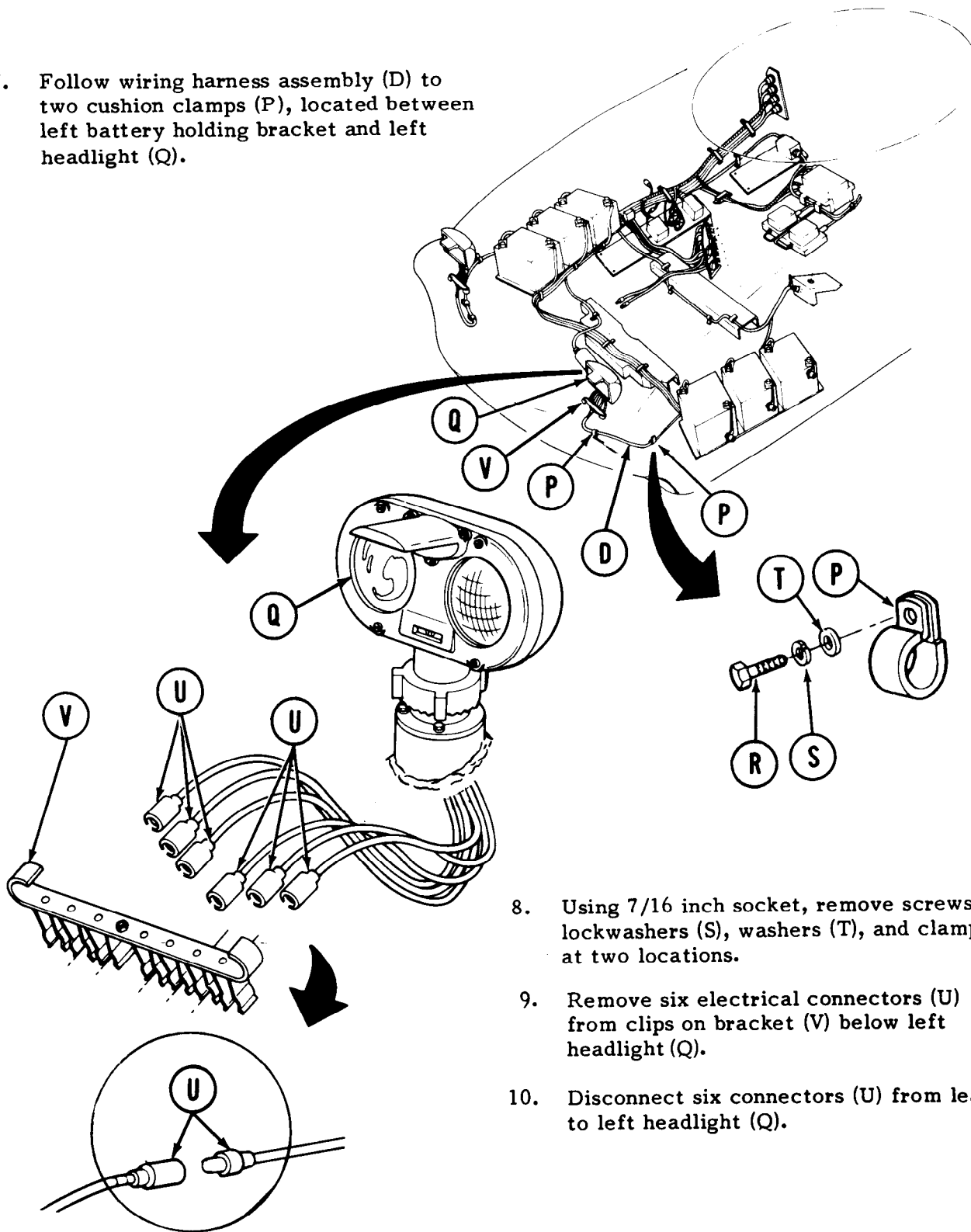

8. Using 7/16 inch socket, remove screws (R), lockwashers (S), washers (T), and clamps (P) at two locations.
9. Remove six electrical connectors (U) from clips on bracket (V) below left headlight (Q).
10. Disconnect six connectors (U) from leads to left headlight (Q).

Go on to Sheet 4

TA108462

FRONT ACCESSORY HARNESS REPLACEMENT (Sheet 4 of 14)

11. Follow wiring harness assembly (D) along front edge of subfloor (W).
12. Using 7/16 inch socket, remove two screws (X), lockwashers (Y), and cushion clamps (Z).
13. Using 9/16 inch socket, remove two screws (AA), lockwashers (AB), and cushion clamps (AC).
14. Follow wiring harness assembly (D) to right side of vehicle.

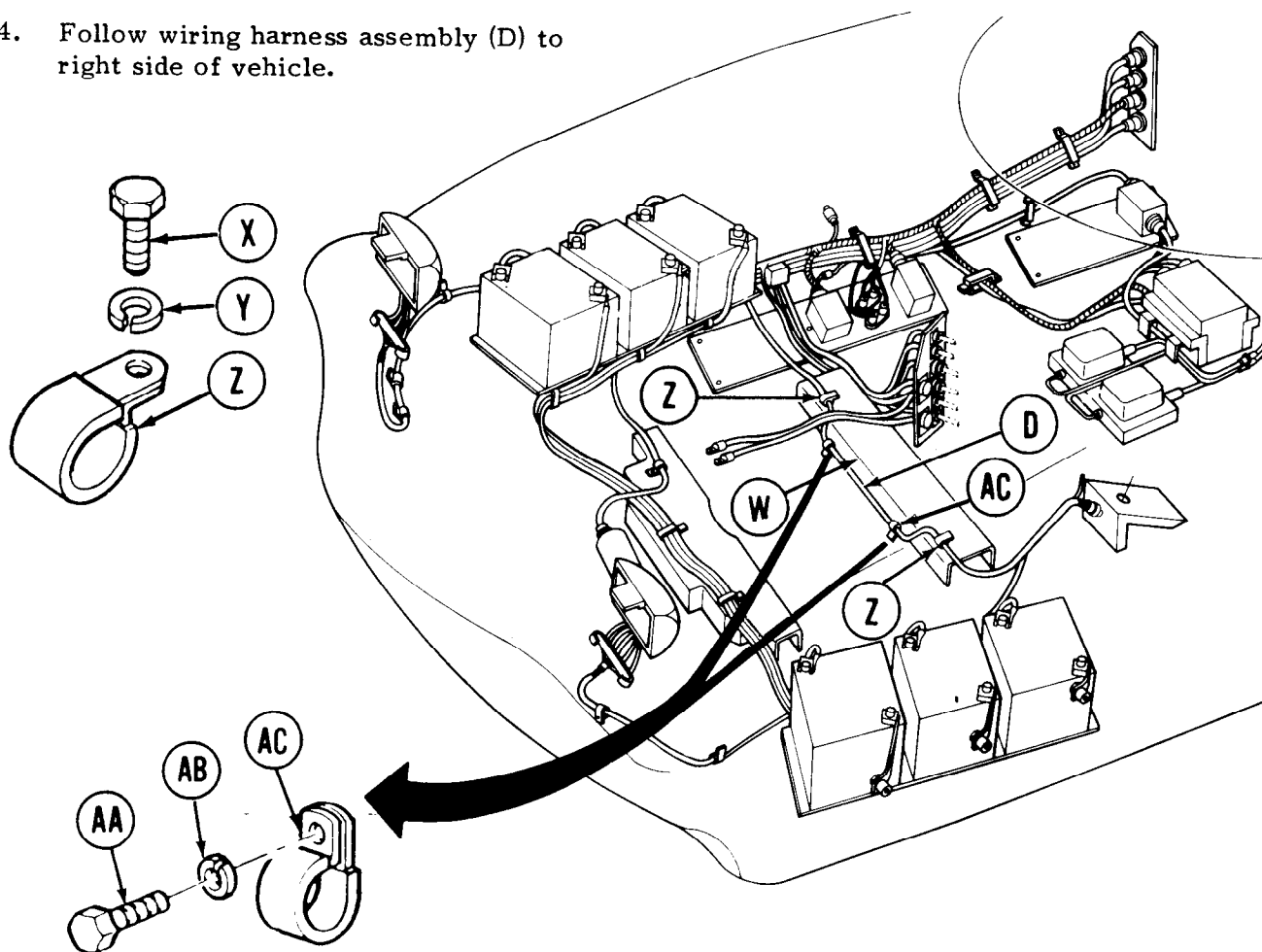

Go on to Sheet 5

TA108463

FRONT ACCESSORY HARNESS REPLACEMENT (Sheet 5 of 14)

15. Using 7/16 inch socket, remove screw (AD), lockwasher (AE), and flat washer (AF) from one end of two straps (AG).
16. Using 5/8 inch open end wrench, remove nut (AH) and disconnect lead (AJ) from center battery terminal.
17. Follow wiring harness assembly (D) to three straps (AK) between right battery holding bracket and right headlight (AL).

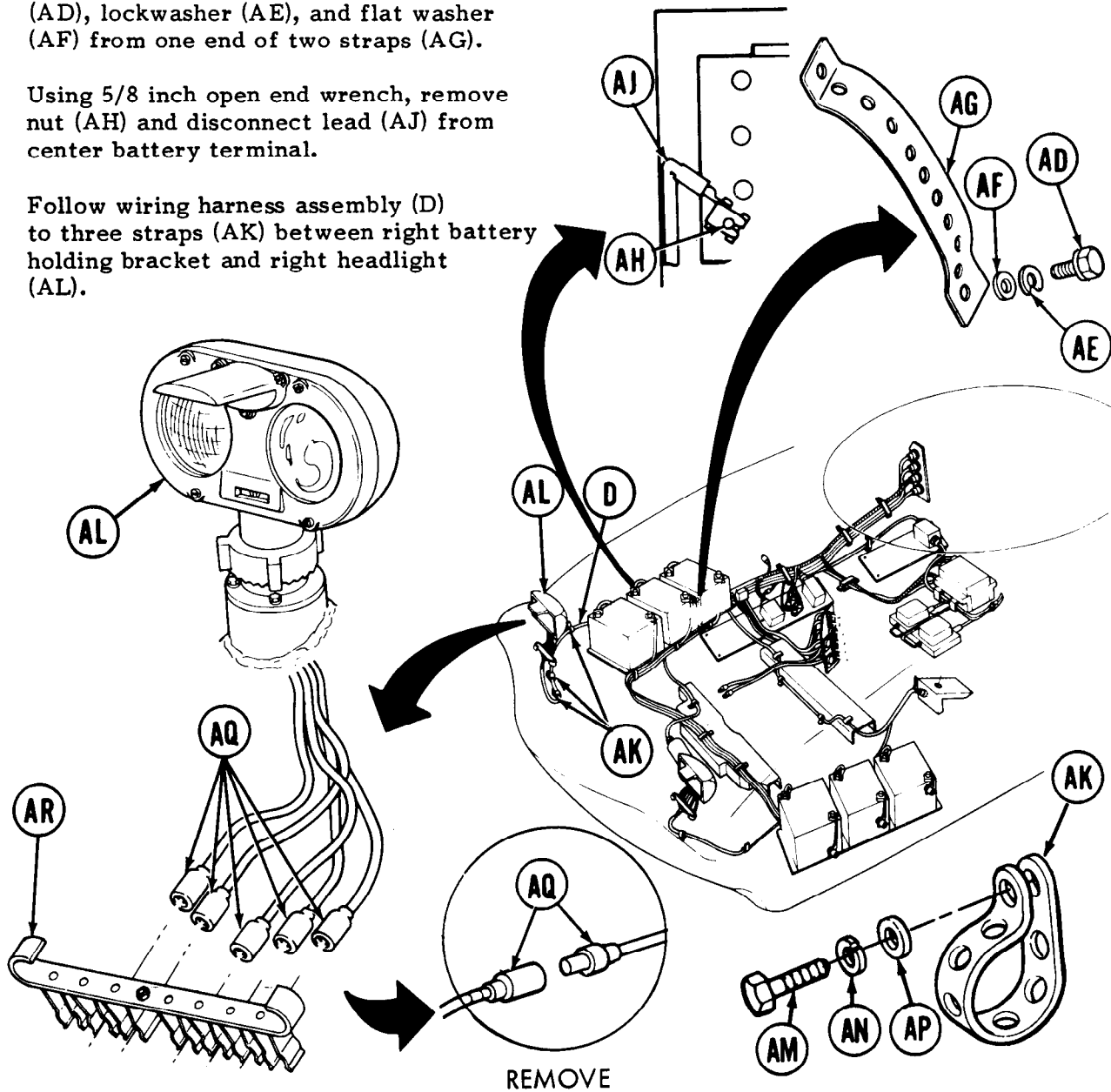

18. Using 7/16 inch socket, remove three screws (AM), lockwashers (AN), flat washers (AP), and straps (AK).
19. Remove five connectors (AQ) from clips on bracket (AR) below right headlight (AL).
20. Disconnect five connectors (AQ) from leads to right headlight (AL).
21. Disconnect one connector (AQ) from dummy load.

Go on to Sheet 6

TA108464

FRONT ACCESSORY HARNESS REPLACEMENT (Sheet 6 of 14)

22. Using spanner wrench, remove top five connectors (AS) at basket disconnect.
23. Follow wiring harness assembly (D) to straps (AT) located between bulkhead connector (AU) and air cleaner blower relay (AV) and voltage regulator (AW).

24. Using 7/16 inch socket, remove screw (AX), lockwasher (AY), and flat washer (AZ) from one end of five straps (AT).

25. Using 7/16 inch wrench, remove screw (BA), lockwasher (BB), and flat washer (BC) from one end of strap (BD).

26. Follow wiring harness assembly (D) to air cleaner blower relay (AV) and fixed fire extinguisher relay (BE).

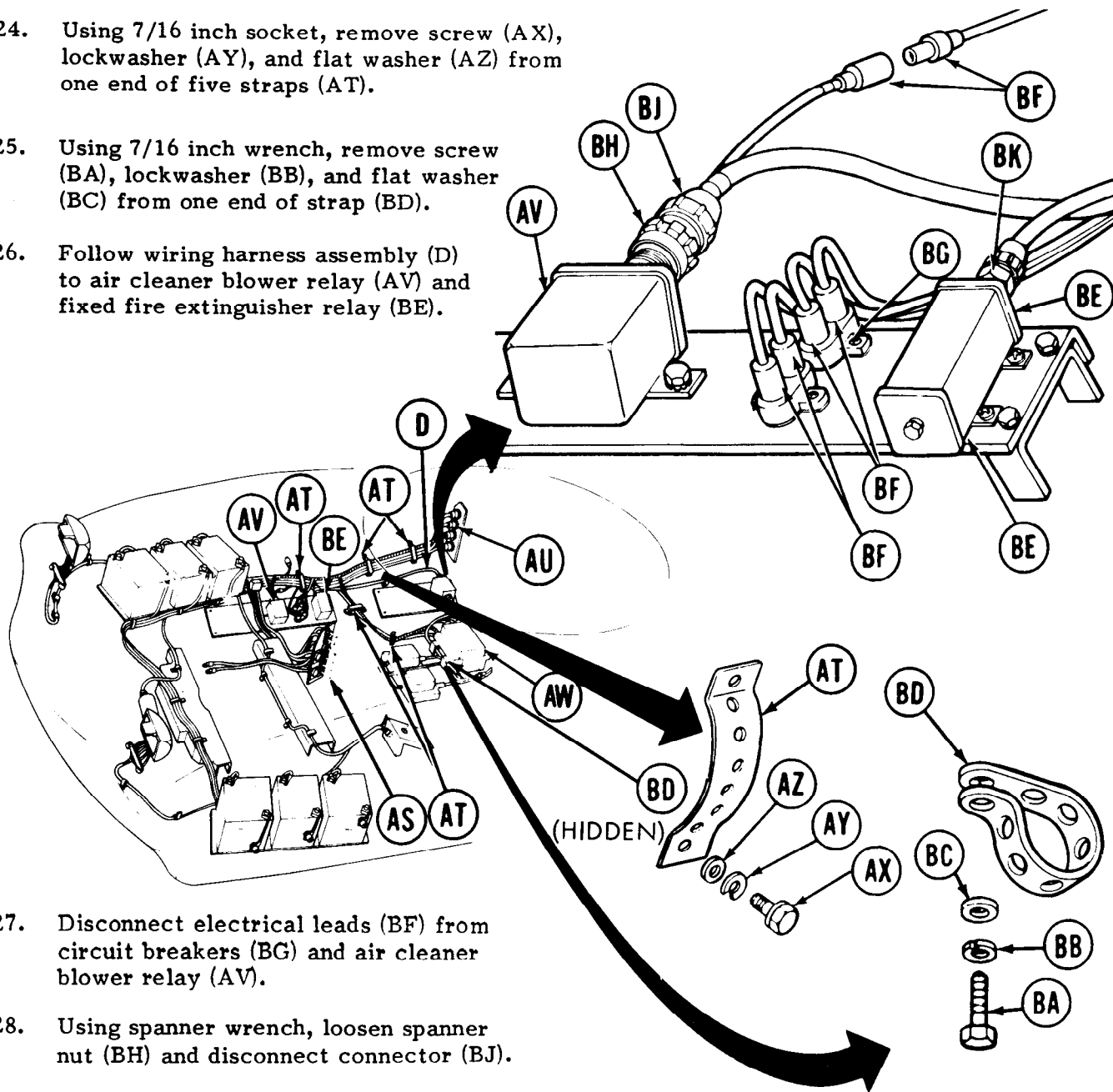

27. Disconnect electrical leads (BF) from circuit breakers (BG) and air cleaner blower relay (AV).
28. Using spanner wrench, loosen spanner nut (BH) and disconnect connector (BJ).
29. Using 1-1/8 inch open end wrench, loosen connector (BK) and disconnect from fixed fire extinguisher relay (BE).

Go on to Sheet 7

TA108465

FRONT ACCESSORY HARNESS REPLACEMENT (Sheet 7 of 14)

- 30. Using 7/16 inch socket, remove screw (BL), clamp (BM), and lockwasher (BN) from between IR power packs (BP) and (BQ).
- 31. Using 7/8 inch open end wrench, loosen and disconnect connectors (BR) and (BS) from IR power packs (BP) and (BQ).

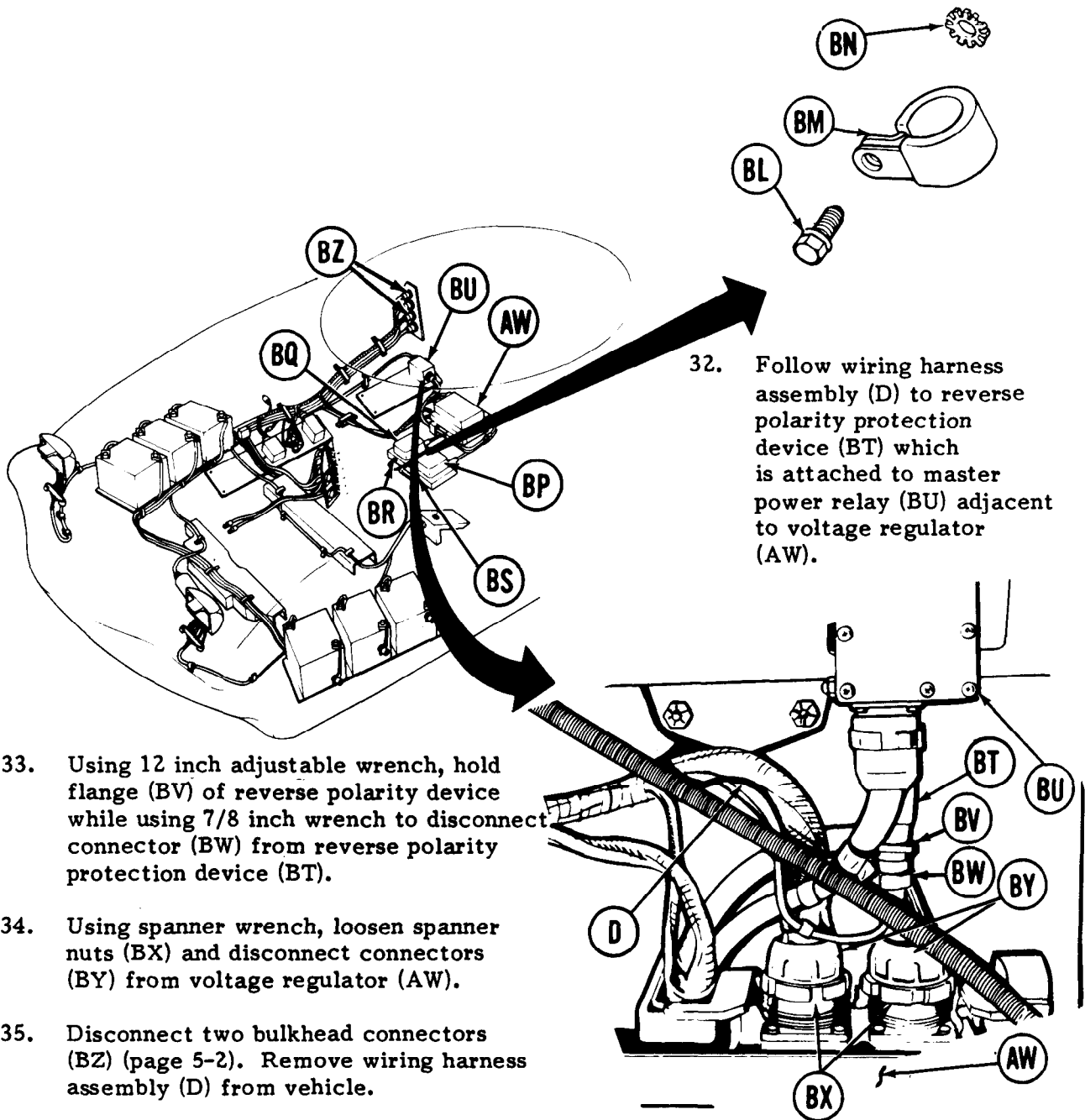

- 32. Follow wiring harness assembly (D) to reverse polarity protection device (BT) which is attached to master power relay (BU) adjacent to voltage regulator (AW).
- 33. Using 12 inch adjustable wrench, hold flange (BV) of reverse polarity device while using 7/8 inch wrench to disconnect connector (BW) from reverse polarity protection device (BT).
- 34. Using spanner wrench, loosen spanner nuts (BX) and disconnect connectors (BY) from voltage regulator (AW).
- 35. Disconnect two bulkhead connectors (BZ) (page 5-2). Remove wiring harness assembly (D) from vehicle.

Go on to Sheet 8

TA108466

FRONT ACCESSORY HARNESS REPLACEMENT (Sheet 8 of 14)

INSTALLATION:

NOTE

Lubricate rubber-to-rubber contact surfaces at assembly of waterproof connectors with silicone compound (Item 10, Appendix B).

NOTE

Note that each lead has a circuit number marker attached to it. Mate each connector to its mating connector, identified by the marker.

1. Position wiring harness (A) in vehicle.

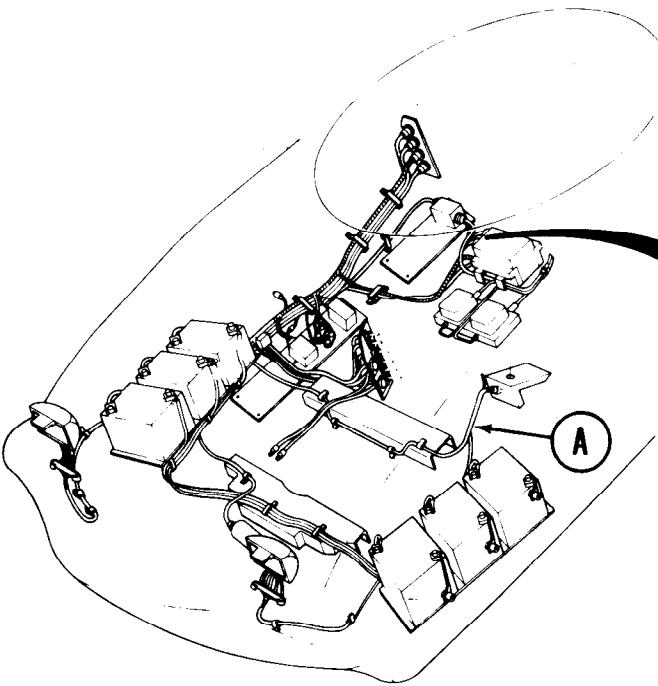

2. Using 12 inch adjustable wrench to hold flange (B) of reverse polarity protection device and 7/8 inch wrench on connector (C), connect connector (C) (CKT 459A) to reverse polarity protection device on master relay.

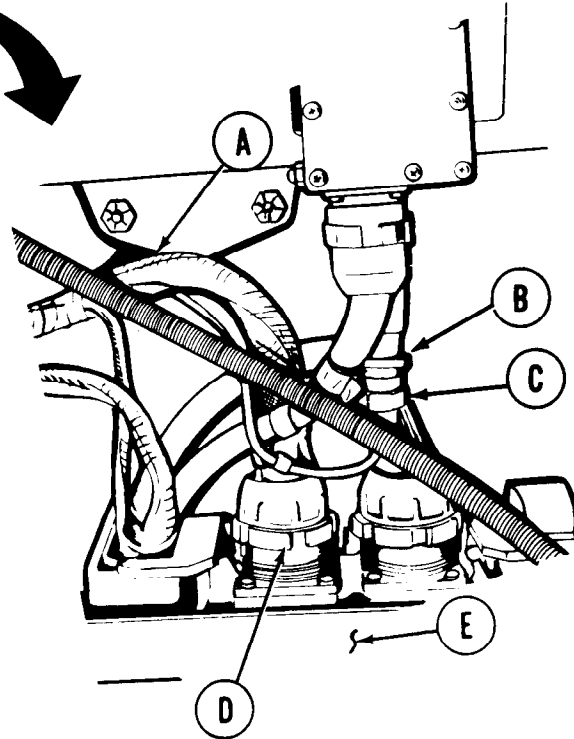

3. Connect connector (D), CKT 415A, 478 and 2, to voltage regulator (E). Using spanner wrench, tighten connector (D).

Go on to Sheet 9

TA108467

FRONT ACCESSORY HARNESS REPLACEMENT (Sheet 9 of 14)

4. Connect connectors (F), CKT 516, to IR power packs (G).
5. Using 7/8 inch open end wrench, tighten connectors (F).
6. Using 7/16 inch socket, install cushion clamp (H), lockwasher (J), and screw (K) to secure wiring harness assembly (A) between IR power packs (G).

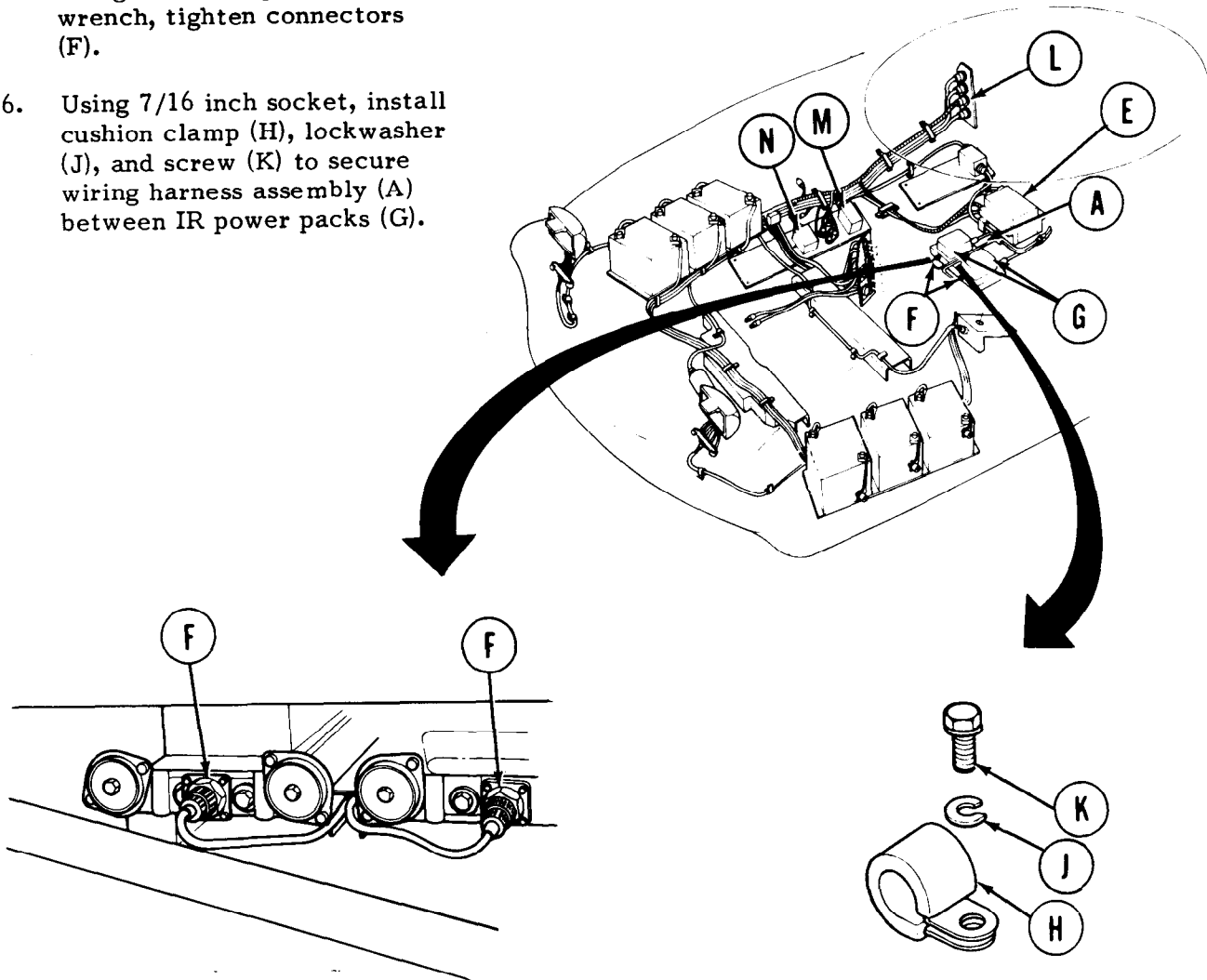

7. Route wiring harness assembly (A) to bulkhead connector (L), fixed fire extinguisher relay (M) and air cleaner blower relay (N).

Go on to Sheet 10

TA108468

FRONT ACCESSORY HARNESS REPLACEMENT (Sheet 10 of 14)

8. Connect two bulkhead connectors (P) (page 5-3).
9. Connect connector (Q), CKT 975, 975A, to fixed fire extinguisher relay (M).
10. Using 1-1/8 inch open end wrench, tighten connector (Q).
11. Connect connectors (R) CKT 975, to circuit breakers (S).
12. Connect connectors (T) CTK 400, 459, to circuit breakers (U).

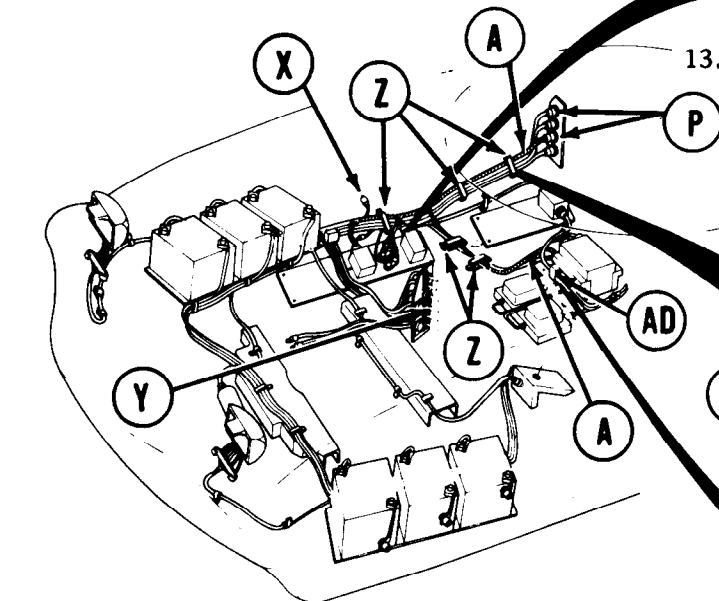
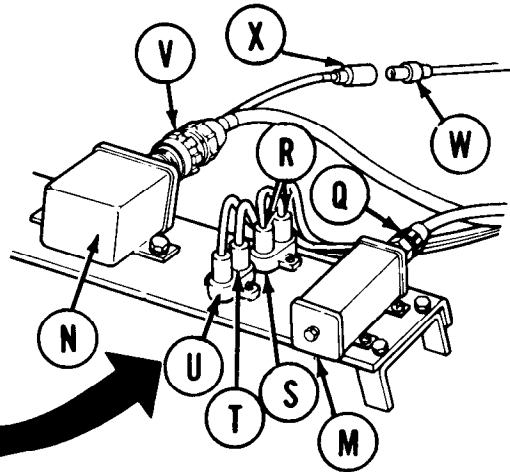

13. Connect connector (V), CKT 415, 415A and 415B, to air cleaner blower relay (N). Using spanner wrench, tighten connector (V).

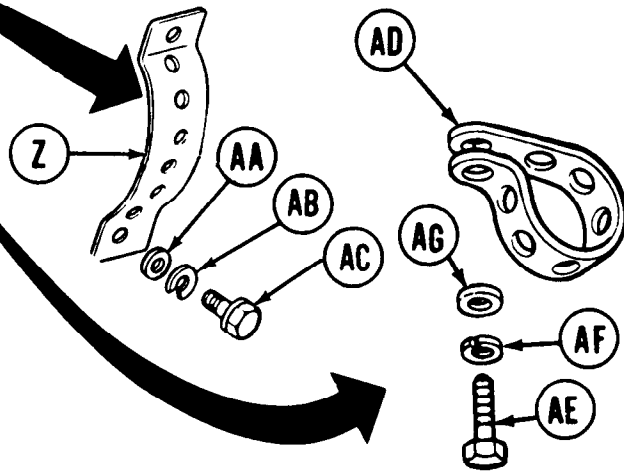

14. Connect electrical lead (W) to blower relay lead (X).
15. Using spanner wrench, install five connectors (Y).
16. Position five straps (Z) over wiring harness assembly (A).
17. Using 7/16 inch socket and ratchet, install flat washers (AA), lockwashers (AB), and screws (AC) securing five straps (Z).
18. Position strap (AD) over wiring harness assembly (A).
19. Using 7/16 inch wrench, install screw (AE), lockwashers (AF), and flat washer (AG) securing strap (AD).

Go on to Sheet 11

TA108469

FRONT ACCESSORY HARNESS REPLACEMENT (Sheet 11 of 14)

20. Route wiring harness assembly (A) along right side of hull to clip bracket assembly (AH) below right headlight.

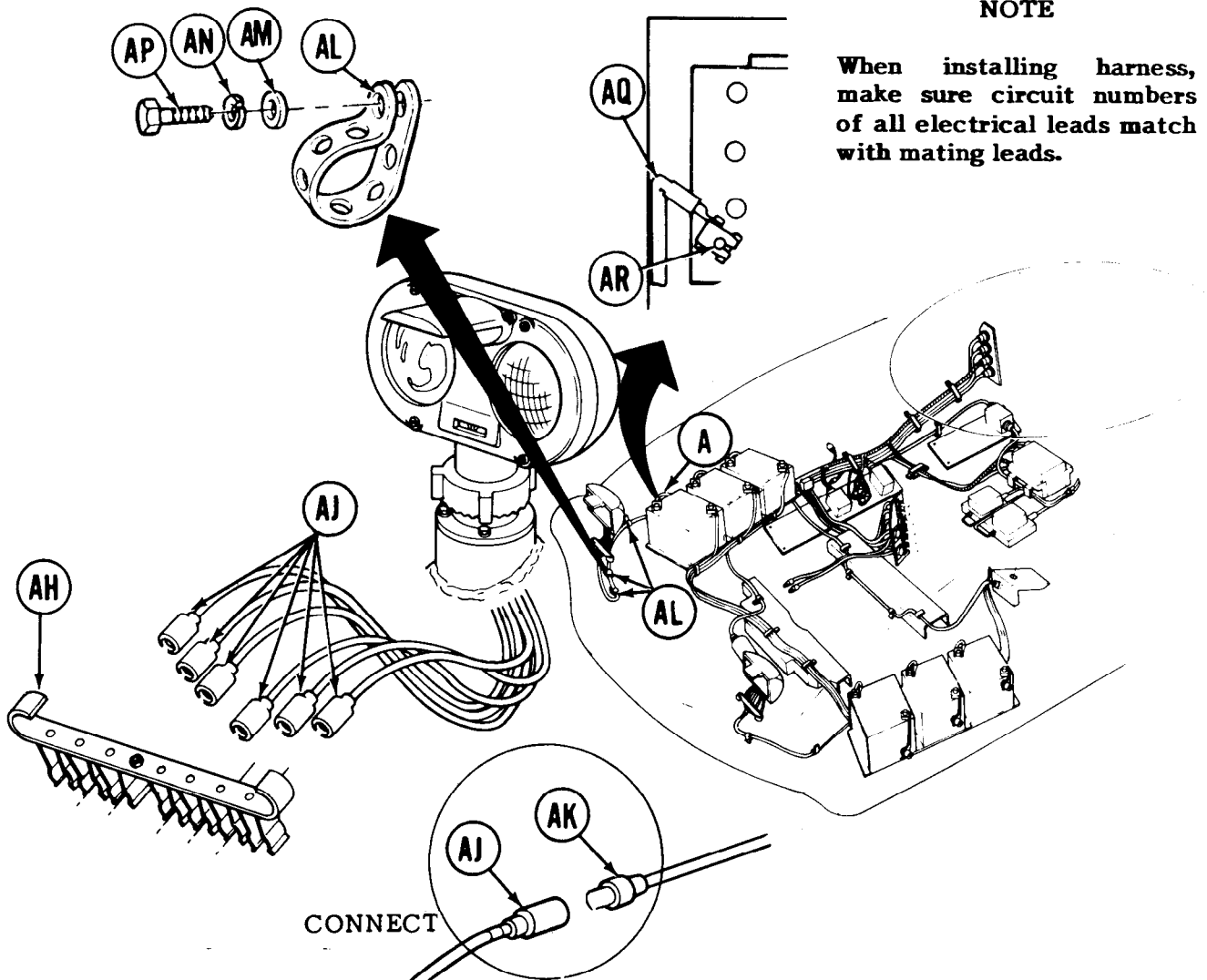

21. Connect five connectors (AJ), CKT 17, 18, 20, 514, and 515 to connectors (AK). Press connectors into clips of bracket (AH).
22. Connect connector (AJ) CKT 19 to dummy load in bracket (AH).
23. Using 7/16 inch socket, install three straps (AL), flat washers (AM), lockwashers (AN), and screws (AP) securing wiring harness assembly (A).
24. Using 5/8 inch open end wrench, install electrical lead (AQ) and nut (AR) to terminal of center battery.

Go on to Sheet 12

TA108470

FRONT ACCESSORY HARNESS REPLACEMENT (Sheet 12 of 14)

25. Route wiring harness assembly (A) along channel (AS) of hull floor.

26. Using 7/16 inch socket, install four cushion clamps (AT), screws (AU), and lockwashers (AV) to secure wiring harness assembly (A).

27. Using 9/16 inch socket, install two clamps (AW), screws (AX), and lockwashers (AY).

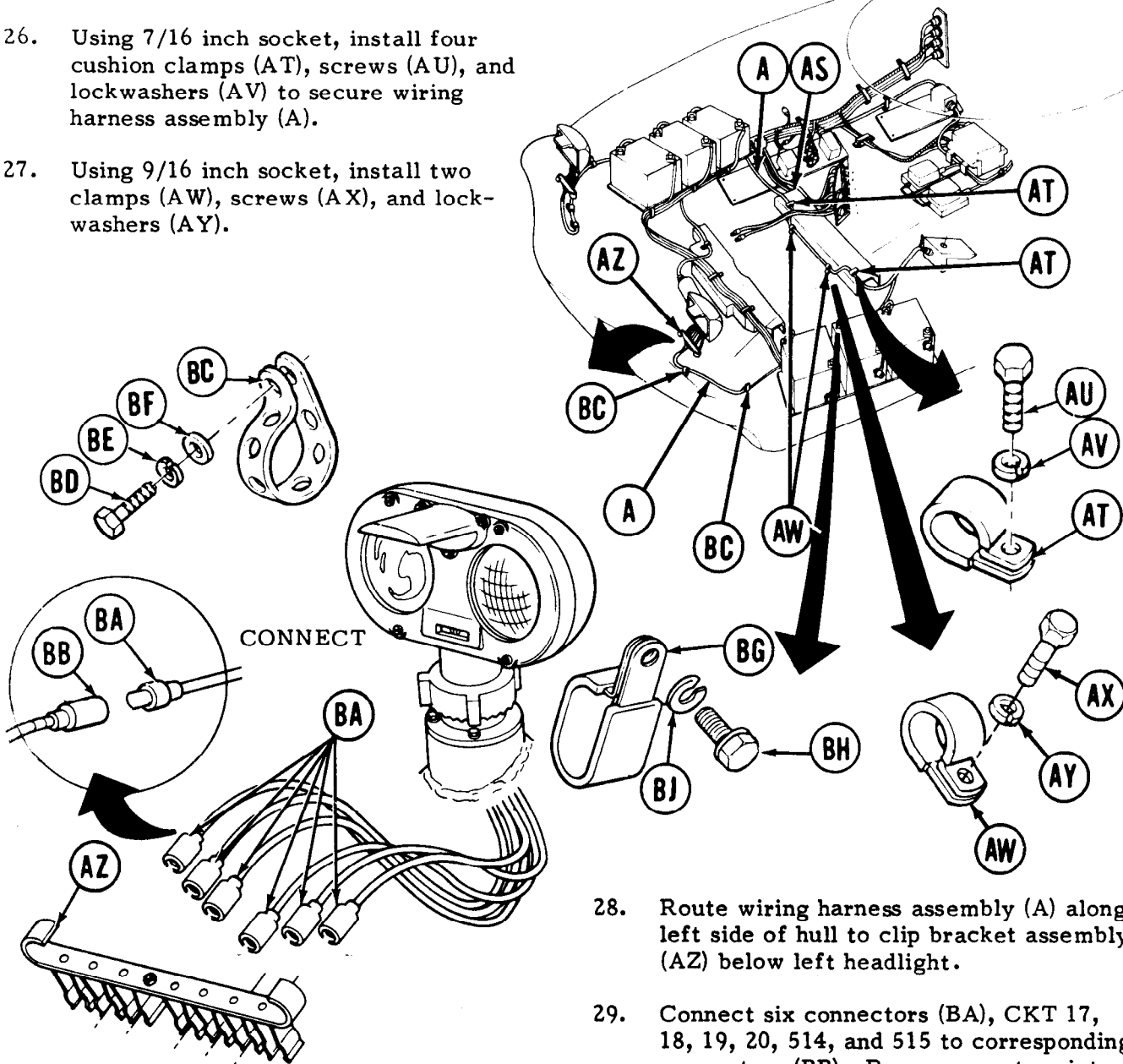

28. Route wiring harness assembly (A) along left side of hull to clip bracket assembly (AZ) below left headlight.

29. Connect six connectors (BA), CKT 17, 18, 19, 20, 514, and 515 to corresponding connectors (BB). Press connectors into bracket clips.

30. Using socket, install two straps (BC), screws (BD), lockwashers (BE), and flat washers (BF).

31. Using socket and ratchet, install three cushion clamps (BG), screws (BH), and lockwashers (BJ).

Go on to Sheet 13

TA108471

FRONT ACCESSORY HARNESS REPLACEMENT (Sheet 13 of 14)

32. Connect two electrical leads (BK), CKT 975, to leads (BL) from fixed fire extinguisher interior release handle.
33. Connect connector (BM) to dimmer switch. Using spanner wrench, tighten connector (BM).

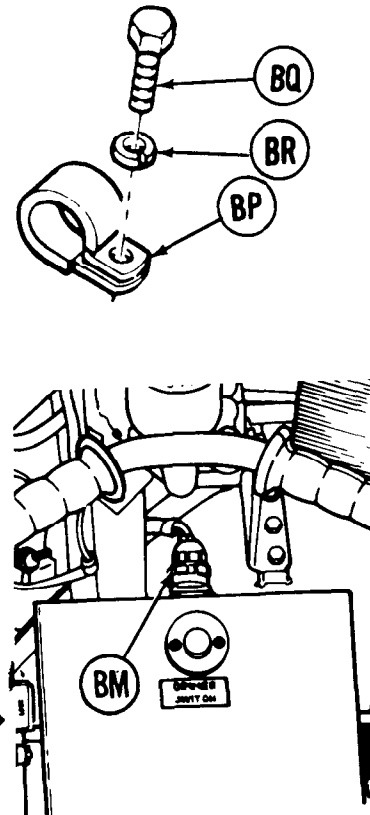
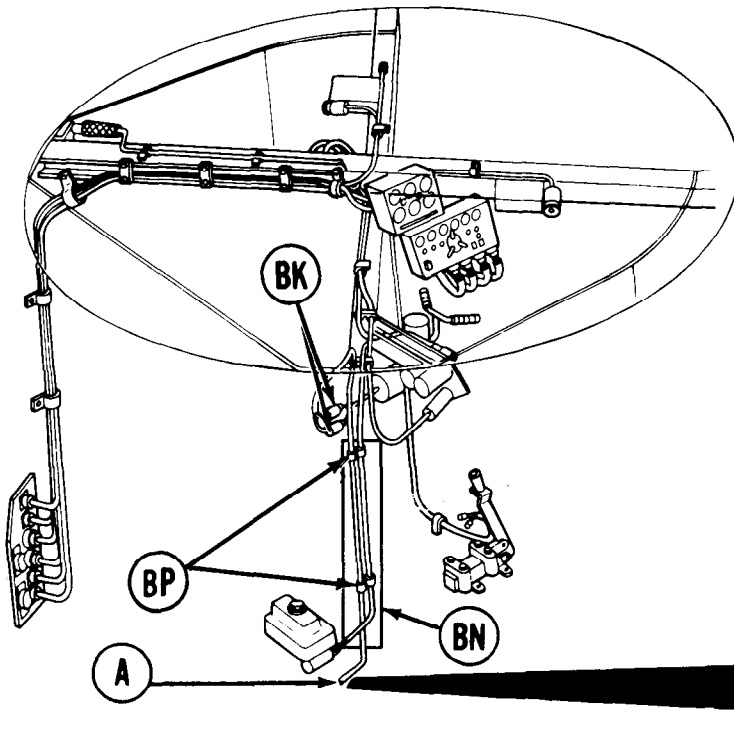
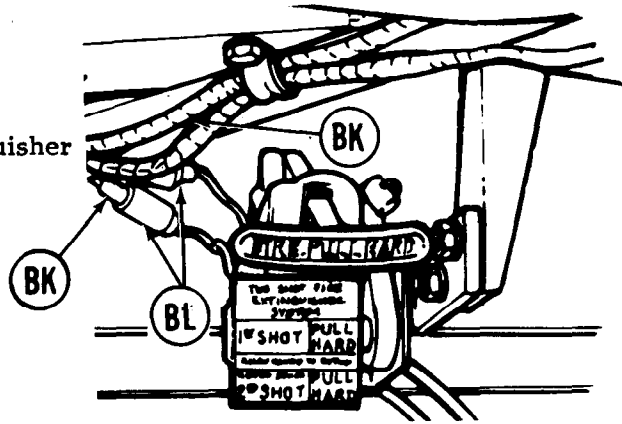

34. Using 7/16 inch socket, secure wiring harness assembly (A) to vertical post (BN), located to left and forward of driver's seat, with clamps (BP), screws (BQ), and lockwashers (BR).

Go on to Sheet 14

TA108472

FRONT ACCESSORY HARNESS REPLACEMENT (Sheet 14 of 14)

35. Install access cover under commander's periscope stowage box (TM 5-5420-226-20).
36. Install commander's periscope stowage box (TM 5-5420-226-20).
37. Install access cover under commander's seat (TM 5-5420-226-20).
38. Lower commander's seat (TM 5-5420-226-10).
39. Connect basket connectors (page 5-73).
40. Connect bulkhead connectors (page 5-3).
41. Install ground straps at batteries (TM 5-5420-226-20).

End of Task

CHAPTER 6
TRANSMISSION MAINTENANCE
INDEX

Procedure	Page
Shifting Control Connecting Link Replacement and Repair	6-2
Shifting Control Sleeve Assembly Replacement and Repair	6-5
Shifting Control Rod Assembly Replacement	6-9
Rear Shifting Linkage Shield Assembly Repair	6-11
Shifting Control Shield Support Replacement	6-14
Rear Shifting Control Rod Replacement	6-16
Shift Rod Locking Hasp Replacement	6-18
Transmission Replacement	6-19

SHIFTING CONTROL CONNECTING LINK REPLACEMENT AND REPAIR (Sheet 1 of 3)

TOOLS: Hammer
1/8 in. drive punch
5/8 in. combination box and open end wrench (2 required)
Vise

SUPPLIES: Pin (2 required)

REFERENCE: TM 5-5420-226-20

PRELIMINARY PROCEDURES: Remove shifting control sleeve (page 6-5)
Disconnect control rod at rear link assembly (TM 5-5420-226-20)

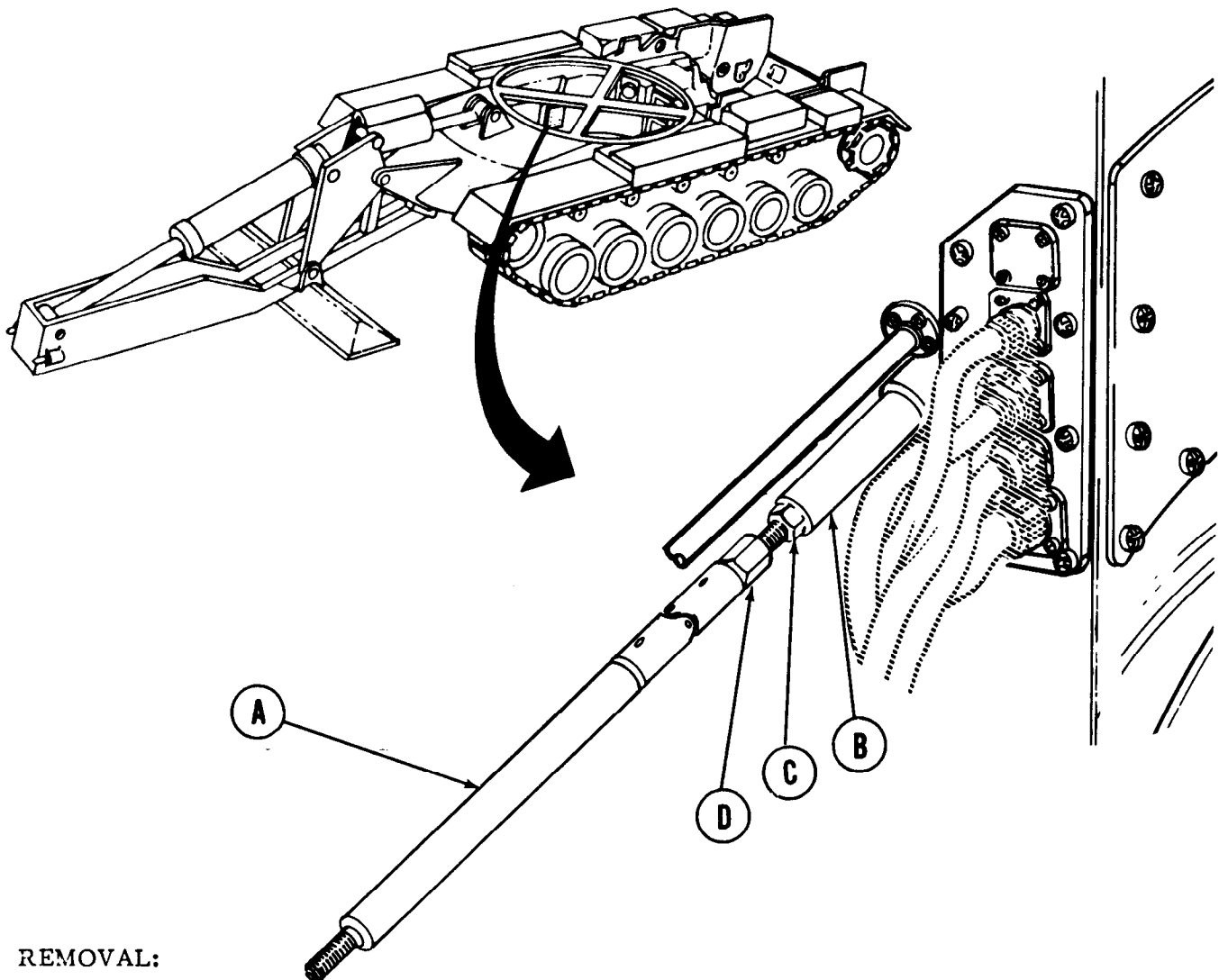

REMOVAL:

1. Using hands, pull shaft (A) forward until shaft (B) is exposed at bulkhead.
2. Using 5/8 inch wrench to hold jamnut (C), use another 5/8 inch wrench on plug (D) to remove shaft assembly (A).

Go on to Sheet 2

TA108473

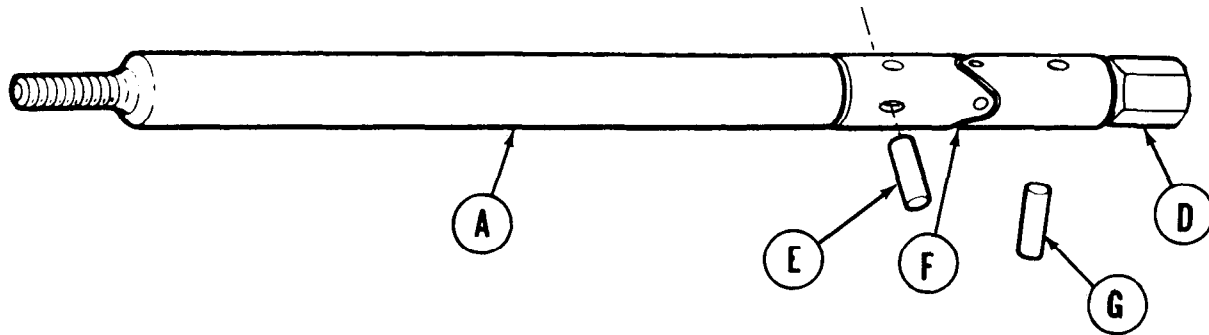
SHIFTING CONTROL CONNECTING LINK REPLACEMENT AND REPAIR (Sheet 2 of 3)

3. Position shaft (A) in vise and, using hammer and punch, remove pin (E) from universal joint (F). Throw pin (E) away.
4. Using hammer and punch, remove pin (G) from universal joint (F). Throw pin (G) away.
5. Remove plug (D) from universal joint (F).
6. Remove shaft (A) from universal joint (F).
7. Inspect shaft (A), universal joint (F), and plug (D) for looseness and wear. Replace defective parts.

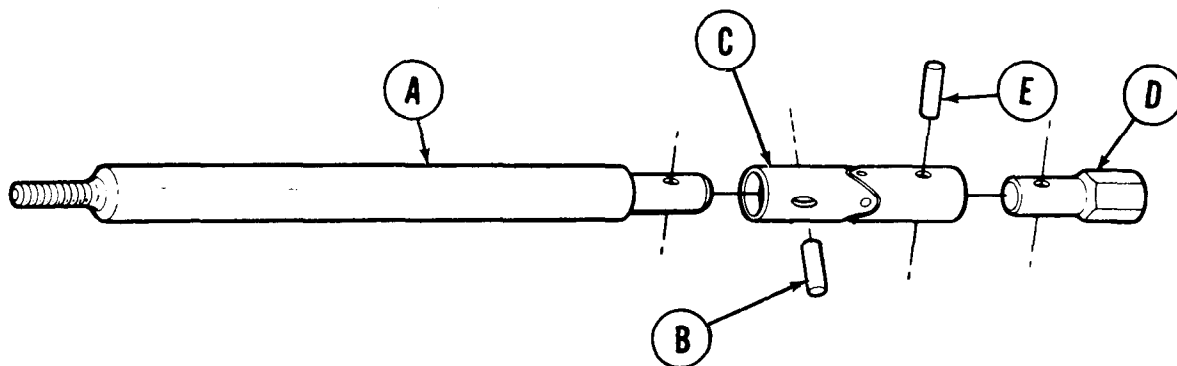
INSTALLATION:

1. Position shaft (A) in vise and, using hammer and punch, install new pin (B) into universal joint (C) and shaft (A).
2. Position plug (D) into universal joint (C) and, using hammer and punch, install pin (E) into universal joint (C) and plug (D).

Go on to Sheet 3

TA108474

SHIFTING CONTROL CONNECTING LINK REPLACEMENT AND REPAIR (Sheet 3 of 3)

3. Remove shaft assembly (A) from vise and take it to crew compartment.

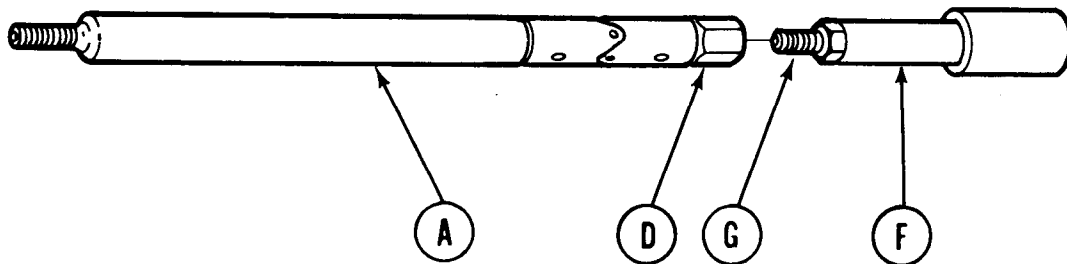

4. Position shaft assembly (A) onto shaft (F). Using 5/8 inch wrench to hold jamnut (G), use another 5/8 inch wrench on plug (D), tighten plug (D) against jamnut (G).
5. Install shifting control sleeve (page 6-8).
6. Install rod assembly, engine compartment rear rod (page 6-17).
7. Adjust shifting linkage (TM 5-5420-226-20).

End of Task

TA108475

SHIFTING CONTROL SLEEVE ASSEMBLY REPLACEMENT AND REPAIR (Sheet 1 of 4)

PROCEDURE INDEX

PROCEDURE	PAGE
Removal	6-5
Disassembly	6-6
Assembly	6-7
Installation	6-8

TOOLS: 6 in. rule
 5/16 in. combination box and open end wrench
 7/16 in. combination box and open end wrench
 9/16 in. combination box and open end wrench (2 required)
 Hammer
 Vise

Torque wrench with 1/2 in. drive (0-175 lb-ft) (0-237 N.m)
 9/16 in. crowfoot wrench with 1/2 in. drive
 9/16 in. socket with 1/2 in. drive
 7/16 in. crowfoot wrench with 1/2 in. drive

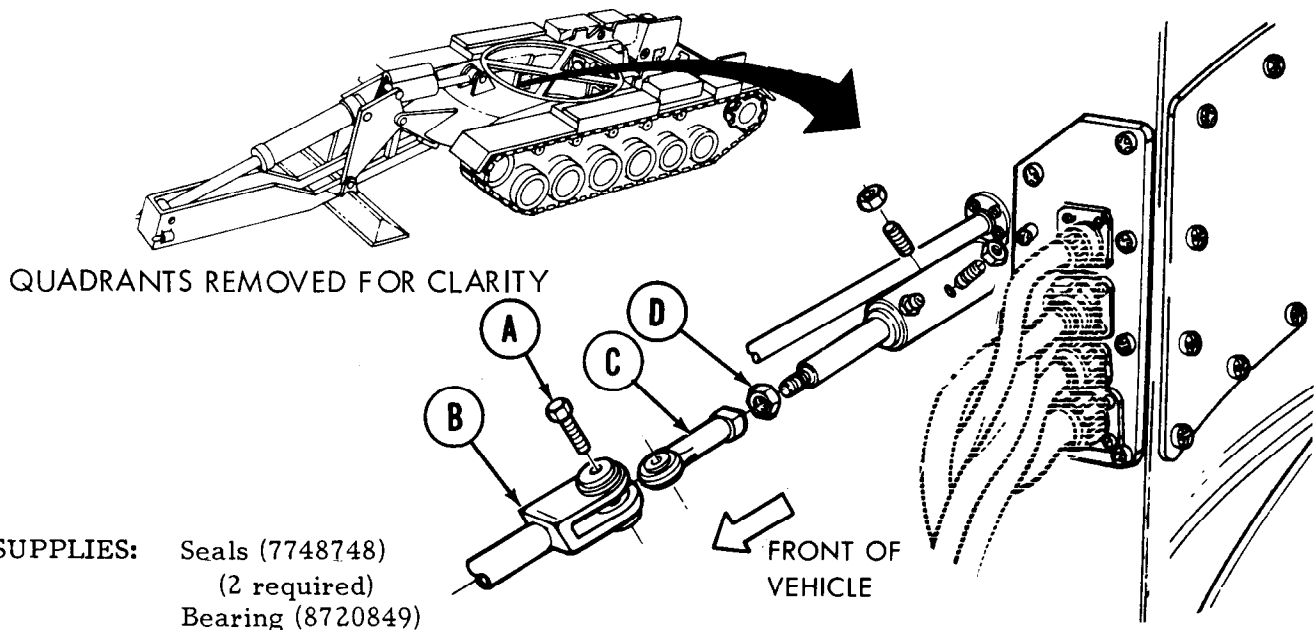

SUPPLIES: Seals (7748748)
 (2 required)
 Bearing (8720849)

FABRICATED TOOL: Bearing installation and removal tool (Figure D-2, Appendix D)

REMOVAL:

- Using 9/16 inch wrench, remove screw (A) securing front intermediate rod (B) to bulkhead shaft rod end (C).
- Using 9/16 inch wrench to hold nut (D), use 9/16 inch wrench and remove rod end (C).

Go on to Sheet 2

TA108476

SHIFTING CONTROL SLEEVE ASSEMBLY REPLACEMENT AND REPAIR (Sheet 2 of 4)

3. Using 9/16 inch wrench, remove nut (D) from bulkhead shaft (E).
4. Using 7/16 inch wrench on screw locking nuts (F), loosen and remove nuts (F) and screws (G).
5. Slide sleeve assembly (H) toward front of vehicle and off shaft (E).

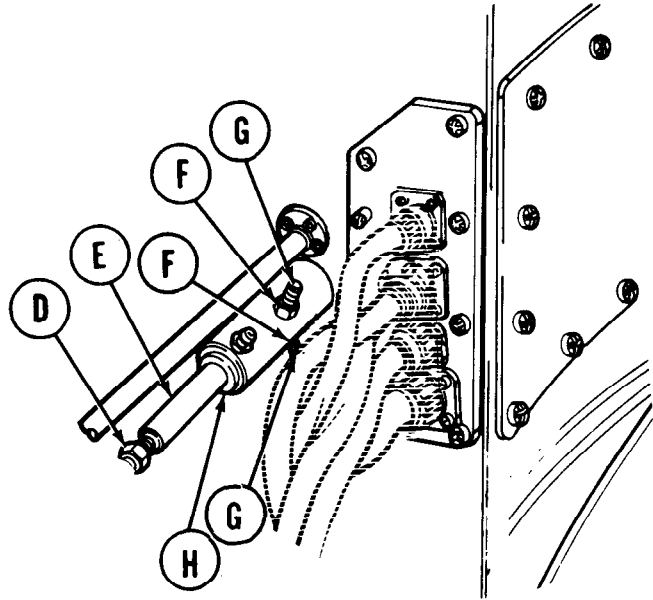

DISASSEMBLY:

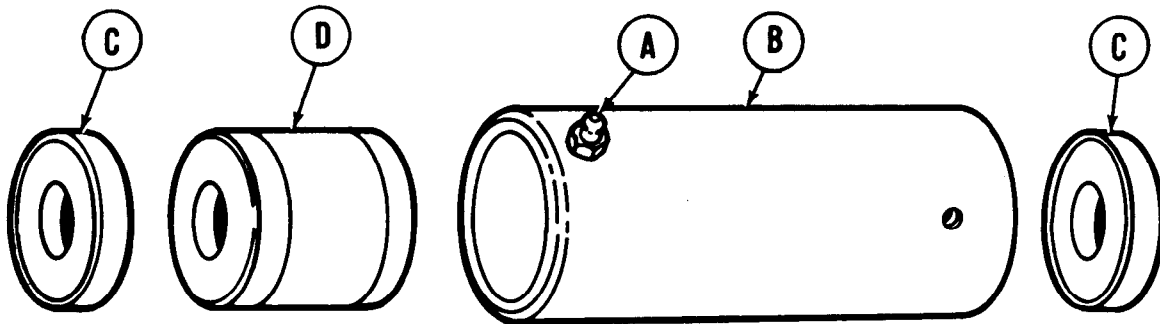

1. Using 5/16 inch wrench, remove grease fitting (A) from sleeve (B).
2. Position sleeve (B) in vise. Using hammer and bearing installation and removal tool, remove two seals (C) and bearing (D) from sleeve (B). Throw seals (C) and bearing (D) away.

Go on to Sheet 3

TA108477

SHIFTING CONTROL SLEEVE ASSEMBLY REPLACEMENT AND REPAIR (Sheet 3 of 4)

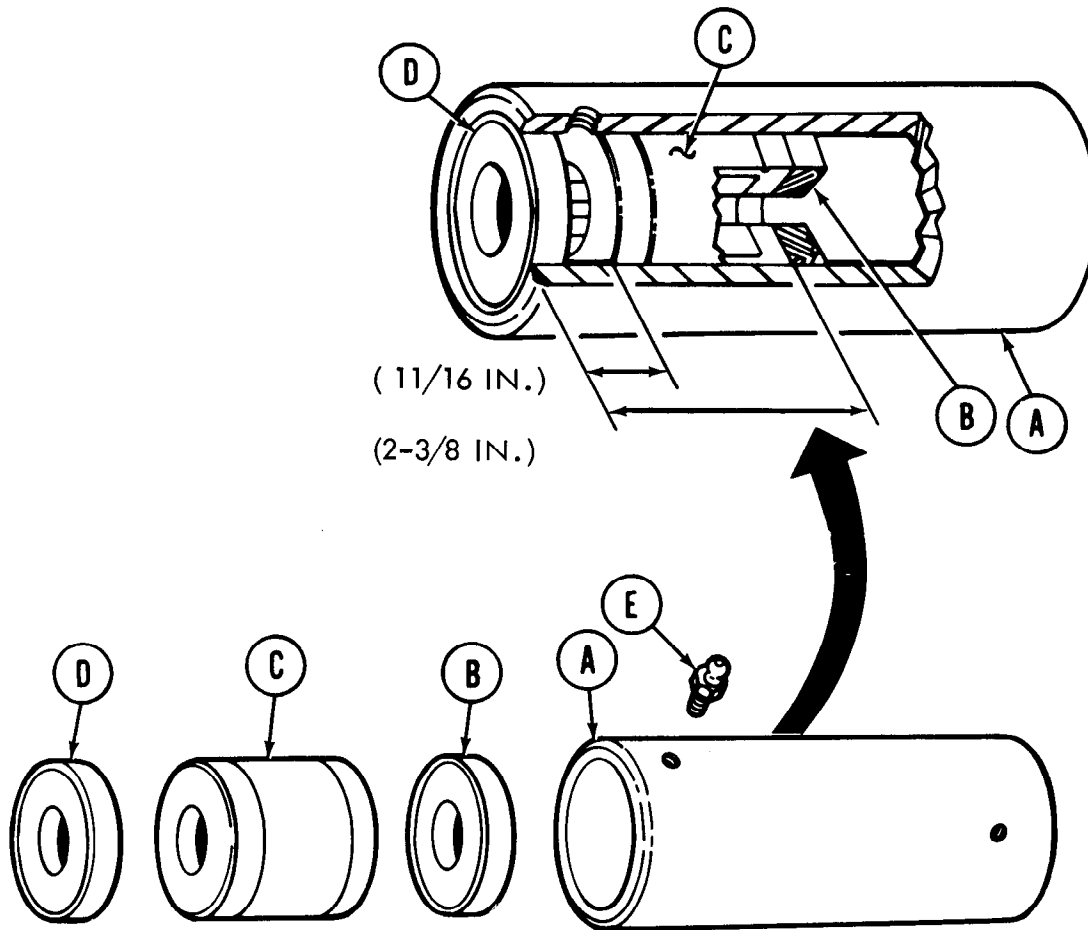

ASSEMBLY:

1. Position sleeve (A) in vise. Using hammer and bearing installation and removal tool, install new seal (B) into sleeve (A) with lip facing outward. Make sure the front part of seal (B) measures 2-3/8 inches from the front of sleeve (A).
2. Using hammer and bearing installation and removal tool, install new bearing (C) into sleeve (A). Make sure bearing fits snug against seal (B) and is 11/16 inch from the front of sleeve (A).
3. Using hammer and bearing installation and removal tool, install new seal (D) into sleeve (A) with lip facing outward.
4. Using 5/16 inch open end wrench, install new grease fitting (E) into sleeve (A).

Go on to Sheet 4

TA108478

SHIFTING CONTROL SLEEVE ASSEMBLY REPLACEMENT AND REPAIR (Sheet 4 of 4)

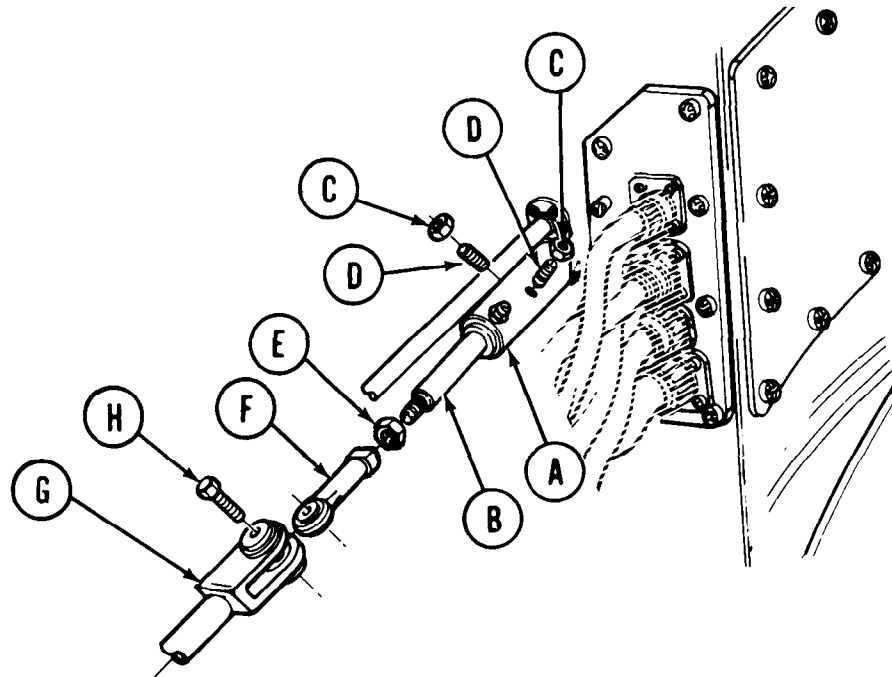

INSTALLATION:

1. Slide sleeve assembly (A) over shaft assembly (B) as far as it will go.
2. Using 7/16 inch wrench to hold nut (C), install two sleeve holding screws (D) through lock nuts (C) into sleeve (A) until screws bottom out on hull connector. Hold screw and, using torque wrench and 7/16 inch crowfoot, tighten nut (C) to 7.5 lb-ft (10 N·m).
3. Using 9/16 inch wrench, install nut (E) onto shaft (B).
4. Using 9/16 inch wrench to hold nut (E), use 9/16 inch wrench to install rod end (F) onto shaft (B). Using torque wrench and 9/16 inch crowfoot, tighten rod end (F) to 16 lb-ft (22 N·m).
5. Position rod end (F) into clevis end (G) and, using 9/16 inch open end wrench, install screw (H) through rod end (F) and clevis end (G). Using torque wrench and 9/16 inch socket, tighten screw to 16 lb-ft (22 N·m).
6. Lubricate linkage (LO 5-5420-226-12).
7. Perform shifting control adjustment as required (TM 5-5420-226-20).

End of Task

TA108479

SHIFTING CONTROL ROD ASSEMBLY REPLACEMENT (Sheet 1 of 2)

- TOOLS:** 1-1/2 lb. hammer
 1/4 in. drive punch
 9/16 in. combination box and open end wrench (2 required)
 9/16 in. crowfoot wrench with 1/2 in. drive
 9/16 in. socket with 1/2 in. drive
 Ratchet with 1/2 in. drive
 Torque wrench with 1/2 in. drive 0-200 lb-in) (0-23 N.m)

SUPPLIES: Pins (MS9390-44)

REFERENCE: TM 5-5420-226-20

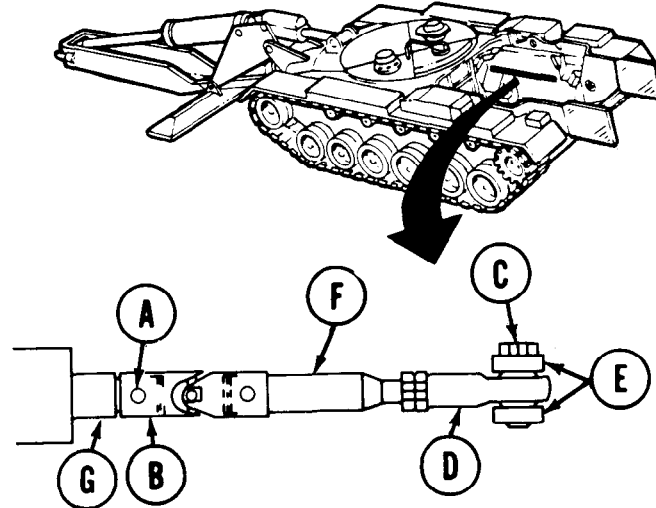

PRELIMINARY PROCEDURE: Remove right fuel tank (page 4-9)

REMOVAL:

1. Using hammer and punch, remove pin (A) from universal joint (B). Throw pin (A) away.
2. Using 9/16 inch wrench, remove screw (C) from rod end (D).
3. Pull rod end (D) from clevis (E).
4. Remove shaft (F) from rod (G).

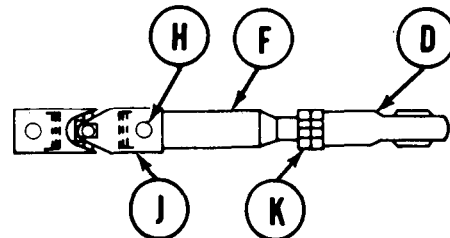

5. Hold shaft (F) in vise. Using hammer and punch, remove pin (H) from universal joint (J). Throw pin (H) away.
6. Remove shaft (F) from universal joint (J).
7. Using 9/16 inch wrench to hold nut (K), use 9/16 inch wrench to remove rod end (D) from shaft (F).
8. Using 9/16 inch wrench, remove nut (K) from shaft (F). Remove shaft (F) from vise.

Go on to Sheet 2

TA108480

SHIFTING CONTROL ROD ASSEMBLY REPLACEMENT (Sheet 2 of 2)

INSPECTION:

Inspect universal joint for ease of movement, rust, and out-of-round holes. Inspect threaded ends for burrs or damaged threads.

INSTALLATION:

1. Position shaft (A) in vise and, install universal joint (B) on shaft (A) with holes aligned. Using hammer and punch, install new pin (C) through universal joint (B) and shaft (A).
2. Using 9/16 inch wrench, install jamnut (D) onto shaft (A).

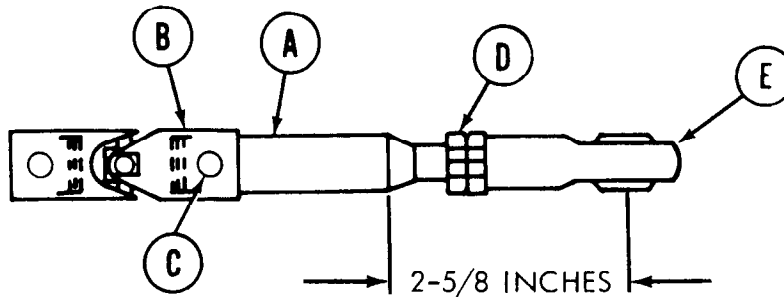

3. Install rod end (E) on shaft (A) until center of rod end is 2-5/8 inch from rod (A). Move jamnut (D) tight against rod end (E).
4. Using torque wrench and 9/16 inch crowfoot, tighten nut (D) against rod end (E) to 190-195 lb-in (21-22 N·m).

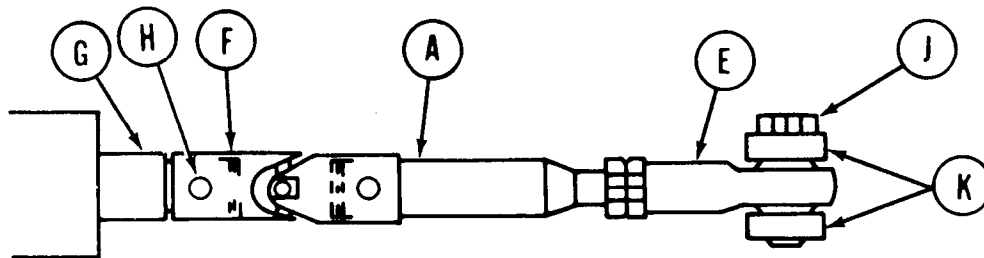

5. Take shaft (A) and universal joint (F) assembly out of vise. Position universal joint to rod (G) with holes aligned. Using hammer, install new pin (H).
6. Using 9/16 inch wrench, install screw (J) through bracket (K) and rod end (E). Using torque wrench and 9/16 inch crowfoot, tighten nut (J) to 190-195 lb-in (21-22 N·m).
7. Adjust shifting linkage (TM 5-5420-226-20).
8. Install right fuel tank (page 4-17).

End of Task

TA108481

REAR SHIFTING LINKAGE SHIELD ASSEMBLY REPAIR (Sheet 1 of 3)

TOOLS: Hammer
Vise

SUPPLIES: Knockout rod (1-1/8 to 1-3/16 in. diameter needed - 51 in. long)
Knockout rod (7/8 in. diameter - 12 in. long)

PRELIMINARY PROCEDURES: Remove right fuel tank (page 4-9)
Remove support straps (center and rear) (page 6-14)

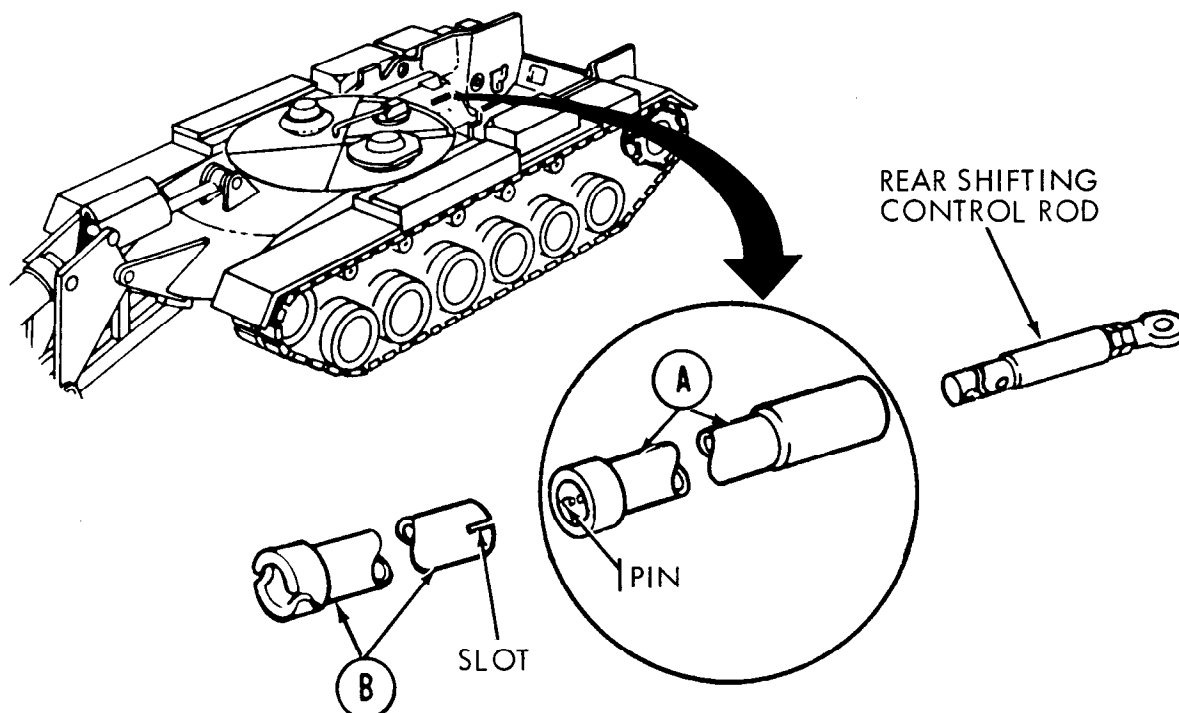
**NOTE**

If linkage shield (A) is stuck and hard to move, shake it with hands or tap it lightly with hammer.

REMOVAL:

1. Using both hands pull shield assembly (A) to rear of vehicle.
2. Remove shield assembly (A) from rear shield (B).

Go on to Sheet 2

TA108482

REAR SHIFTING LINKAGE SHIELD ASSEMBLY REPAIR (Sheet 2 of 3)

DISASSEMBLY:

1. Put shield (A) in vise (or hold shield) with smaller end up.
2. Insert 51 inch long knockout rod through opening at smaller end of shield (A).
3. Using hammer, tap knockout rod to drive out seal (B), bearing (C), and inner seal (D).

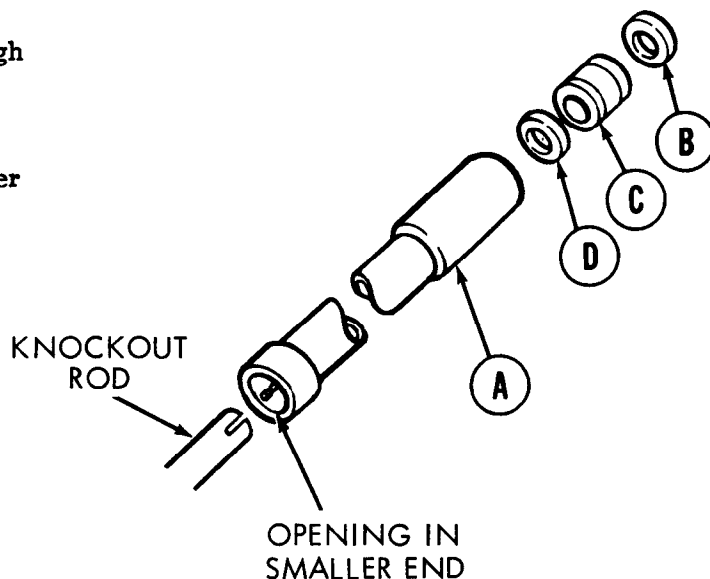

INSPECTION:

Inspect shield for cracks, bends, or other damage.

ASSEMBLY:

1. Position shield (A) in vise (or on ground) with larger end up.
2. Place inner seal (B) in larger end of shield (A).
3. Insert 12 inch long knockout rod into larger end of shield (A). Using hammer, tap rod to drive seal (B) in as far as it will go.

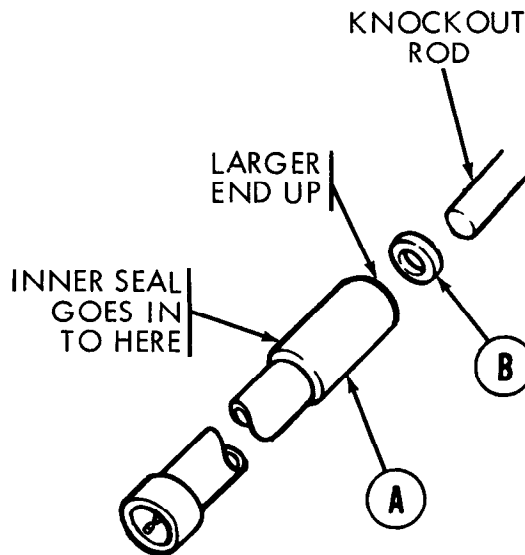

Go on to Sheet 3

TA108483

REAR SHIFTING LINKAGE SHIELD ASSEMBLY REPAIR (Sheet 3 of 3)

4. Position bearing (C) in shield (A).
5. Insert 12 inch long knockout rod to larger end of shield (A).
6. Using hammer, tap rod to drive bearing (C) in as far as it will go.
7. Place outer seal (D) in shield (A).
8. Insert 12 inch long knockout rod, and using hammer, tap rod to drive seal (D) in as far as it will go.

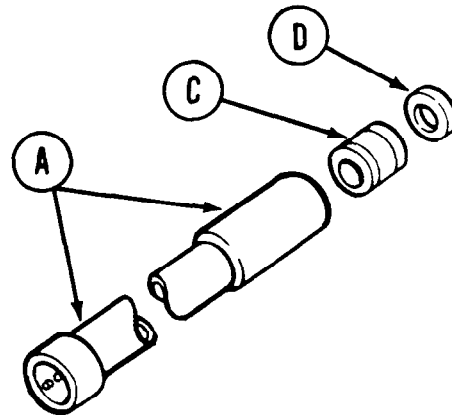
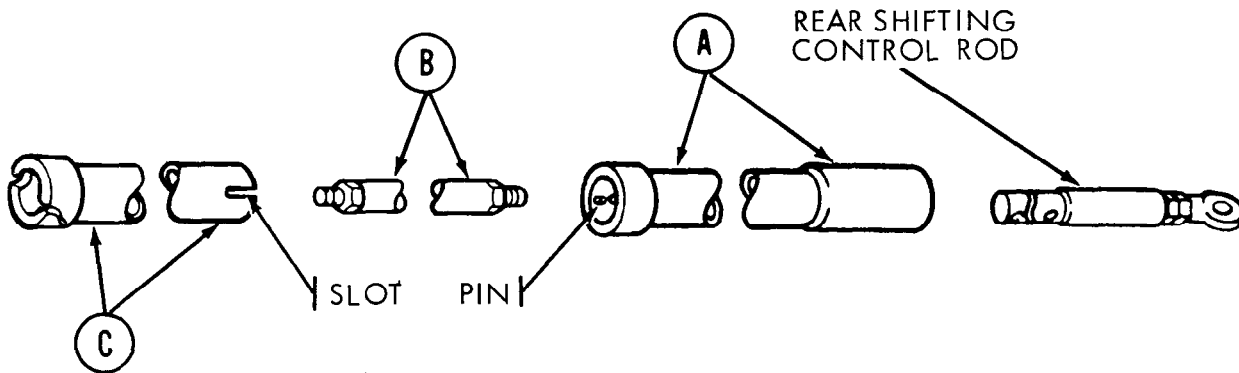
**INSTALLATION:**

1. Slide shield (A) over shifting control rod (B).
2. Aline pins of front shield (A) to slot of rear shield (C).
3. Push shield (A) all the way forward.
4. Install support straps (page 6-15).
5. Install right fuel tank (page 4-17).

End of Task

TA108484

SHIFTING CONTROL SHIELD SUPPORT REPLACEMENT (Sheet 1 of 2)

TOOLS: 0-175 lb-in torque wrench with
1/2 in. drive
1/2 in. socket with 1/2 in. drive
1/2 in. open end wrench

Ratchet with 1/2 in. drive
5/8 in. combination box and
and open end wrench (2 required)

REFERENCE: TM 5-5420-226-20

PRELIMINARY PROCEDURES: Remove right fuel tank (page 4-9)
Disconnect control rod at rear link assembly (TM 5-5420-226-20)

REMOVAL:

1. Using 1/2 inch socket and ratchet, remove four screws (A) and lockwashers (B). Remove straps (C).
2. Slide rear shield (D) back approximately 2 inches toward rear of vehicle.
3. Using two 5/8 inch wrenches, disconnect rear control rod (E).
4. Remove shield (D) and control rod (E).
5. Remove front shield (F) from vehicle.
6. Using 1/2 inch open end wrench to hold screw (G), use 1/2 inch socket and ratchet to remove four nuts (H), lockwashers (J), and washers (M) from screws (G).
7. Remove four screws (G) and two supports (K) from plates (L).

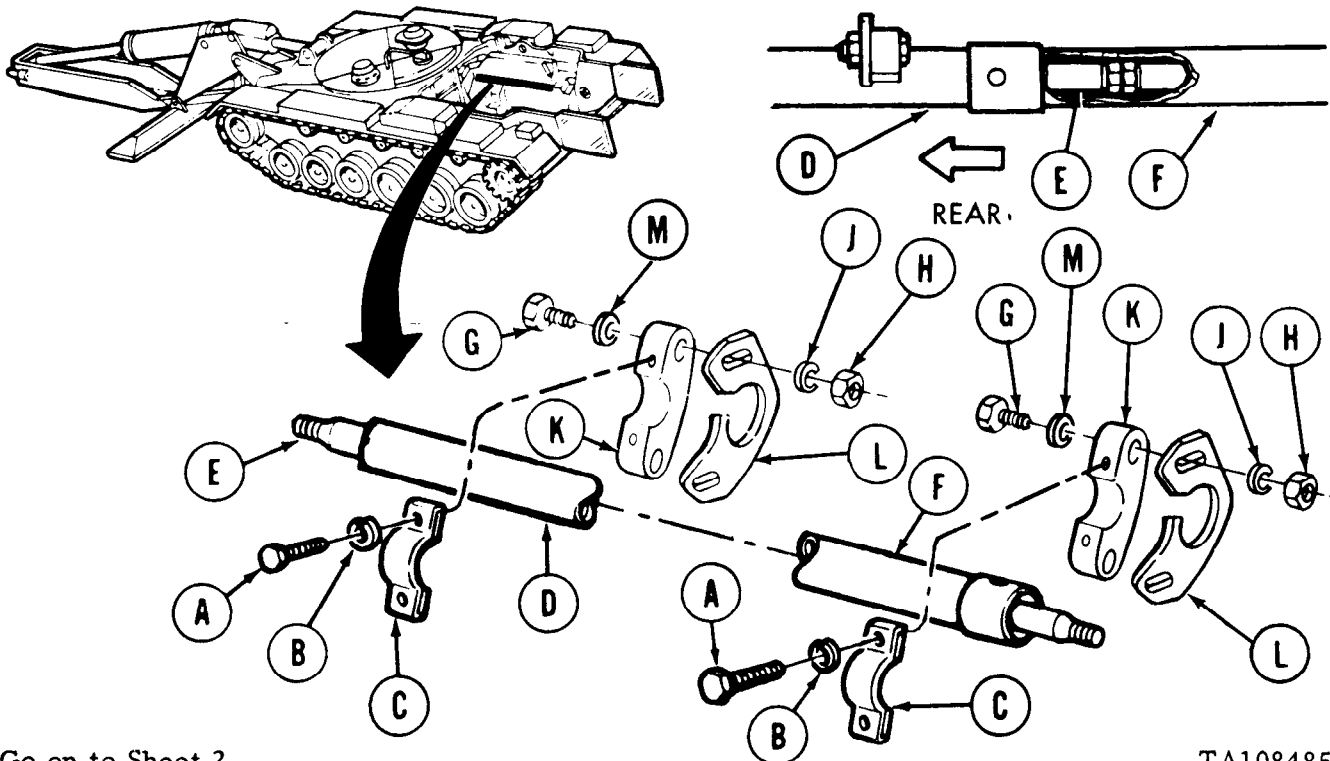

Go on to Sheet 2

TA108485

SHIFTING CONTROL SHIELD SUPPORT REPLACEMENT (Sheet 2 of 2)**INSTALLATION:**

1. Position support (A) onto plate (B) and install four screws (C) through support (A) and plate (B).

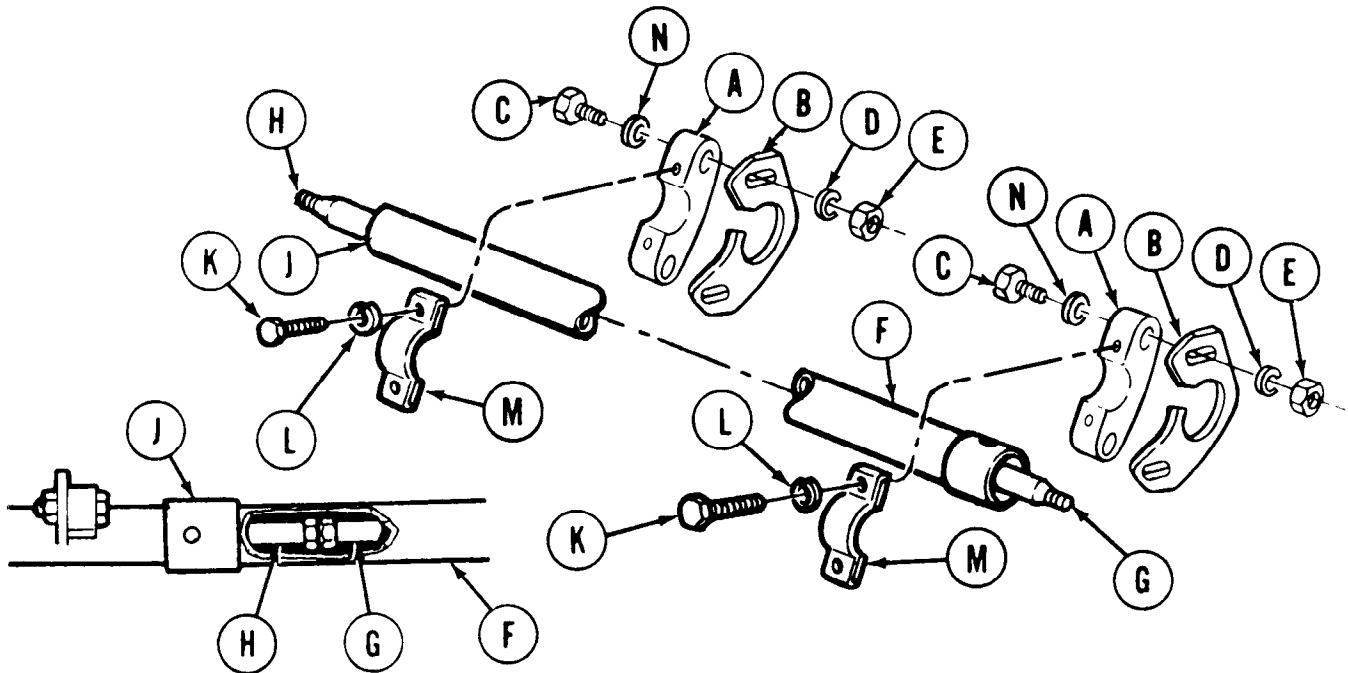

2. Position four washers (N), lockwashers (D), and nuts (E) onto four screws (C).
3. Using 1/2 inch open end wrench to hold screws (C), use torque wrench and 1/2 inch socket to tighten four nuts (E) to 10-12 lb-ft (13.6-16.3 N·m).
4. Place front shield (F) over rod (G).
5. Place rear rod (H) and shield (J) in position. Using two 5/8 inch wrenches, connect front rod (G) and rear rod (H).
6. Move front shield (F) and rear shield (J) toward front of vehicle until secure.
7. Position four screws (K) and four lockwashers (L) through straps (M) into supports (A). Use torque wrench and 1/2 inch socket to tighten four screws (K) to 10-12 lb-ft (13.6-16.3 N·m).
8. Connect rear control rod to clevis (TM 5-5420-226-20).
9. Install right tank (page 4-17).

End of Task

TA108486

REAR SHIFTING CONTROL ROD REPLACEMENT (Sheet 1 of 2)

TOOLS: 5/8 in. open end wrench (2 required)

PRELIMINARY PROCEDURES: Remove right fuel tank (page 4-9)
Remove shifting control rod (page 6-9)
Remove rear shifting linkage shield (page 6-11)

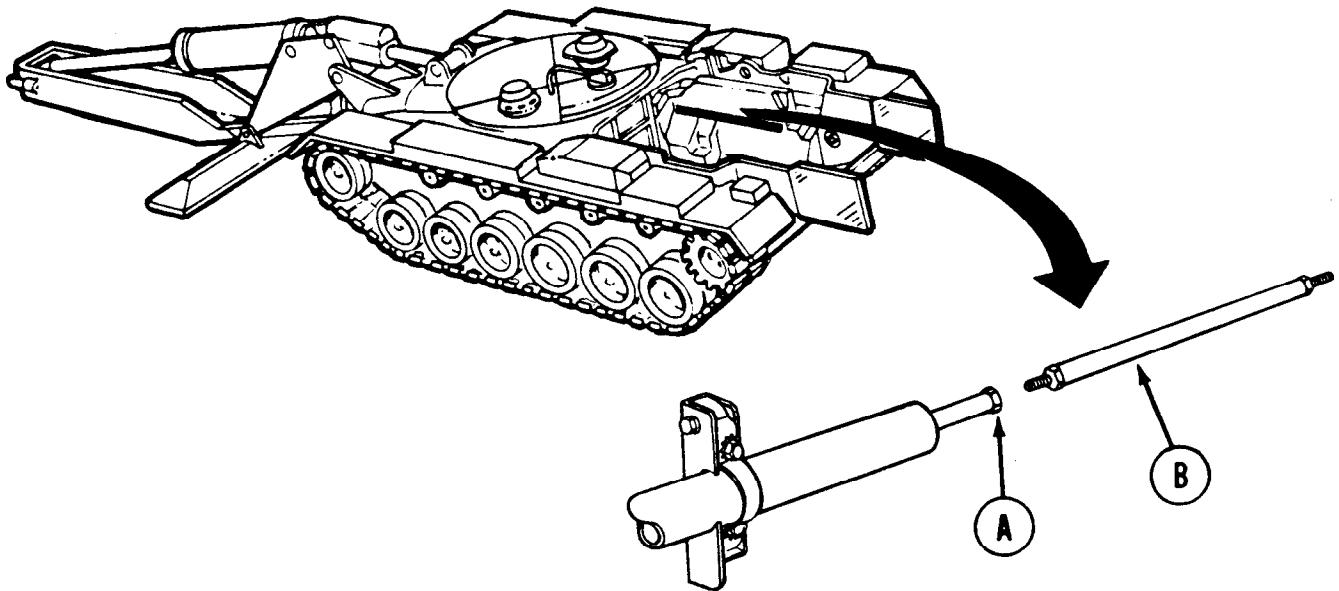

REMOVAL:

1. Using one 5/8 inch wrench to hold front control rod (A), use another 5/8 inch wrench and loosen shifting control rod (B).
2. Remove rod (B) from vehicle.

Go on to Sheet 2

TA108487

REAR SHIFTING CONTROL ROD REPLACEMENT (Sheet 2 of 2)**INSPECTION:**

1. Check rod for cracks, bends, or warpage.
2. Inspect rod for stripped threads. Replace damaged rod.

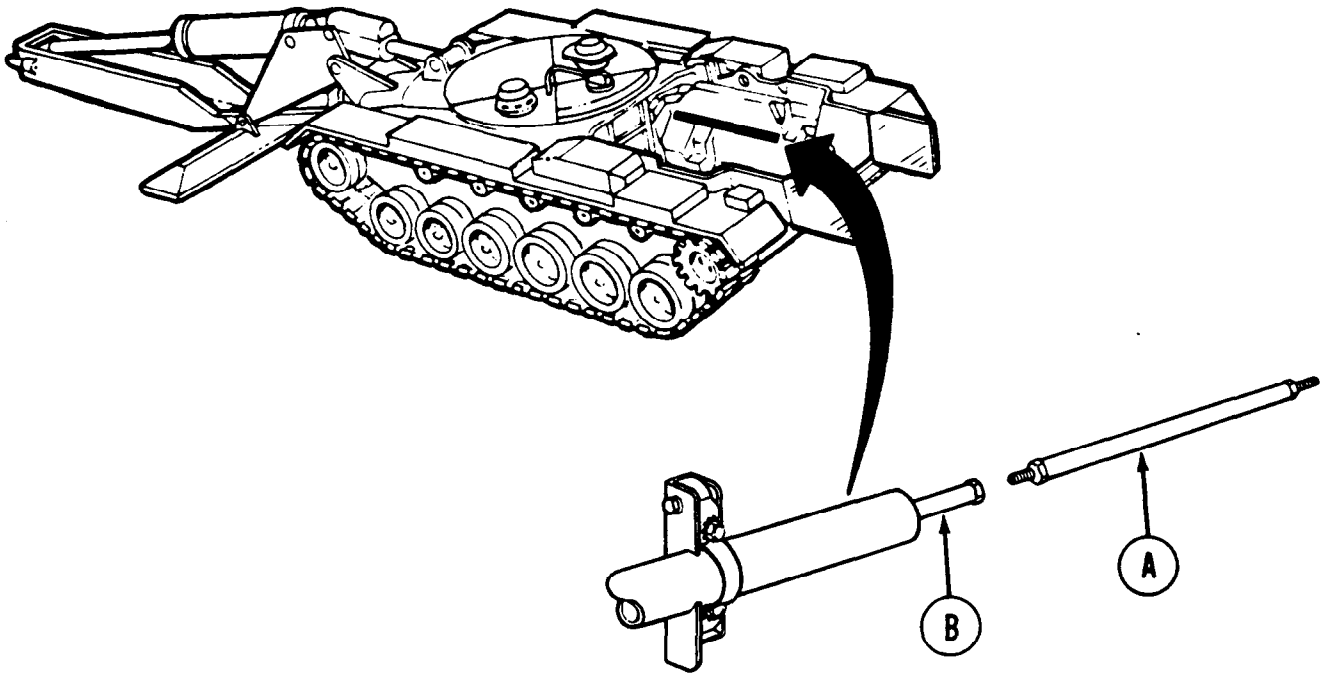
**INSTALLATION:**

1. Install rod (A) into vehicle.
2. Using 5/8 inch wrench to hold rod (B), use another 5/8 inch wrench to tighten rod (A).
3. Install rear shifting linkage shield (page 6-13).
4. Install shifting control rod (page 6-10).
5. Install right fuel tank (page 4-17).

End of Task

TA108488

SHIFT ROD LOCKING HASP REPLACEMENT (Sheet 1 of 1)

TOOLS: Slip joint pliers

SUPPLIES: Cotter pin

REMOVAL:

1. Remove cotter pin (A) from straight pin (B) with pliers. Throw cotter pin (A) away.
2. Remove straight pin (B), spring (C), and hasp (D) from transmission shift base assembly (E).

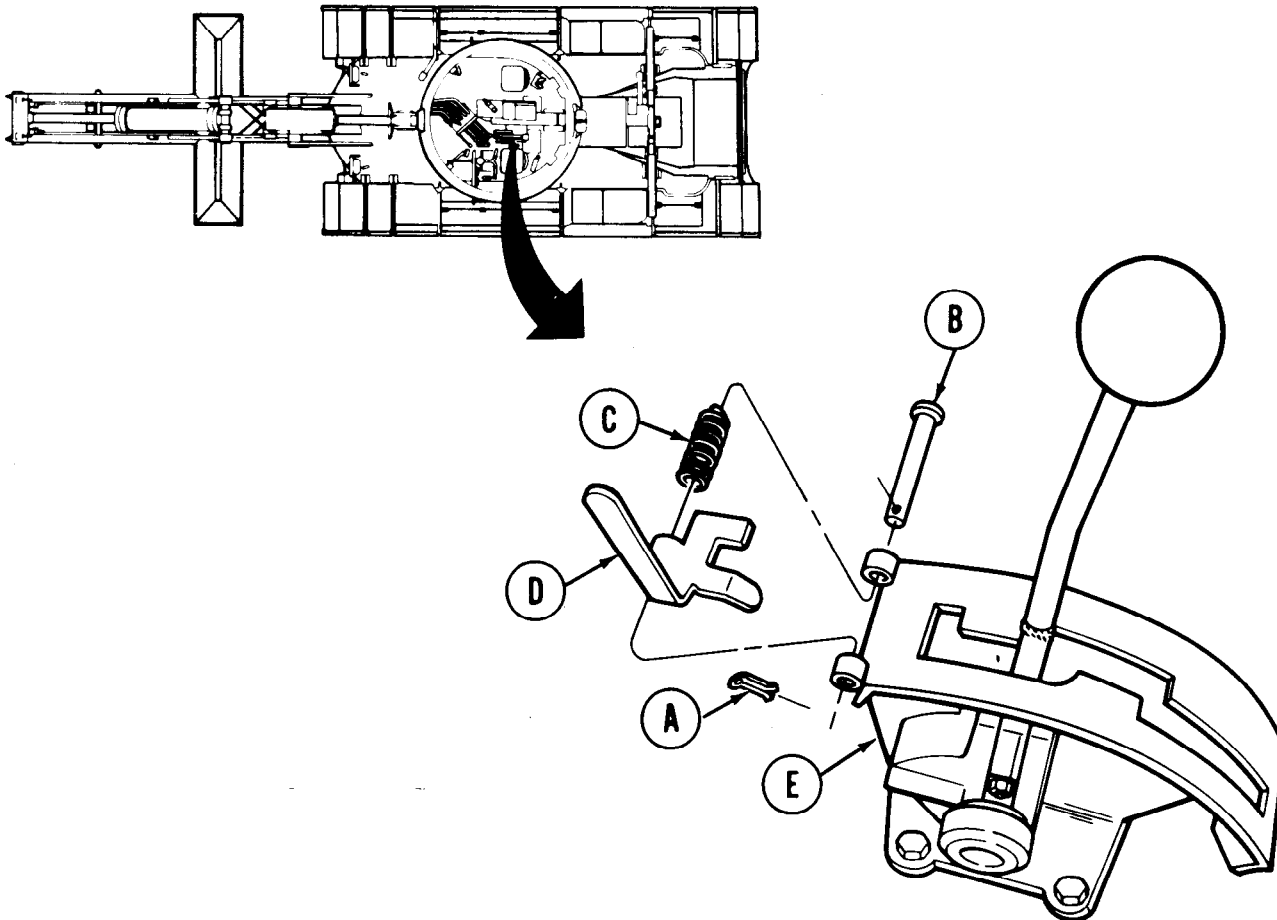

INSTALLATION:

1. Position hasp (D) on base assembly (E).
2. Insert straight pin (B) through base assembly (E), spring (C), and hasp (D).
3. Install cotter pin (A) through straight pin (B). Bend cotter pin (A) with pliers.

End of Task

TA108489

TRANSMISSION REPLACEMENT (Sheet 1 of 23)

PROCEDURE INDEX

PROCEDURE	PAGE
Removal	6-19
Cleaning	6-29
Installation	6-29

<p>TOOLS: 1/2 in. combination box and open end wrench (2 required) 9/16 in. combination box and open end wrench 3/4 in. combination box and open end wrench 7/8 in. combination box and open end wrench 15/16 in. combination box and open end wrench 1-1/2 in. open end wrench 1-5/8 in. open end wrench 1/2 in. socket with 1/2 in. drive 9/16 in. socket with 1/2 in. drive 5/8 in. socket with 1/2 in. drive Hoist (5,000 pounds)</p>	<p>3/4 in. socket with 1/2 in. drive Universal joint with 1/2 in. drive 5 in. extension with 1/2 in. drive 1-1/16 in. socket with 3/4 in. drive Ratchet with 3/4 in. drive 8 in. adjustable wrench Flat-tip screwdriver Slip joint pliers Hose clamp pliers Snap ring pliers Ratchet with 1/2 in. drive Putty knife Pry bar 1-1/8 in. socket with 1/2 in. drive Torque wrench with 3/4 in drive (0-600 lb-ft) (0-813 N·m)</p>
--	---

SPECIAL TOOLS: Puller adapter (Item 2, Chapter 2, Section I)
 Slide hammer puller (Item 3, Chapter 2, Section I)
 Pinion turning wrench (Item 5, Chapter 2, Section I)
 Lifting sling (Item 4, Chapter 2, Section I)

FABRICATED TOOLS: Fabricated wrench (Fig. 1, Appendix D)

<p>SUPPLIES: Gasket (2 required) Cotter pins (2 required) Preformed packing Dry cleaning solvent (Item 12, Appendix B) Lockwashers (11 required) Gloves (Item 31, Appendix B)</p>	<p>Drain pan (suitable container) Rags (Item 35, Appendix B) Wooden blocks, 10 x 10 x 12 in. (2 required) Metallic gasket (4 required) I.D. tags (Item 30, Appendix B) Goggles (Item 32, Appendix B)</p>
---	---

PERSONNEL: Two

REFERENCES: TM 5-5420-226-10
 TM 5-5420-226-20
 LO 5-5420-226-12

PRELIMINARY PROCEDURE: Remove powerplant (TM 5-5420-226-20)

Go on to Sheet 2

TRANSMISSION REPLACEMENT (Sheet 2 of 23)

NOTE

Position powerplant on two 10 x 10 x 12 inch wooden blocks. Position blocks under each end of engine oil pan.

REMOVAL:

1. Using 9/16 inch wrench, remove screw (A) from bracket (B). Remove rod (C) from bracket (B).

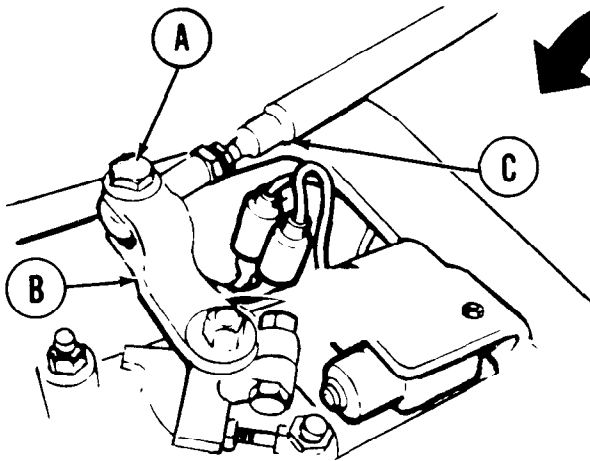

2. Using 3/4 inch socket and ratchet, remove two screws (D) and washers (E) securing bracket (F).

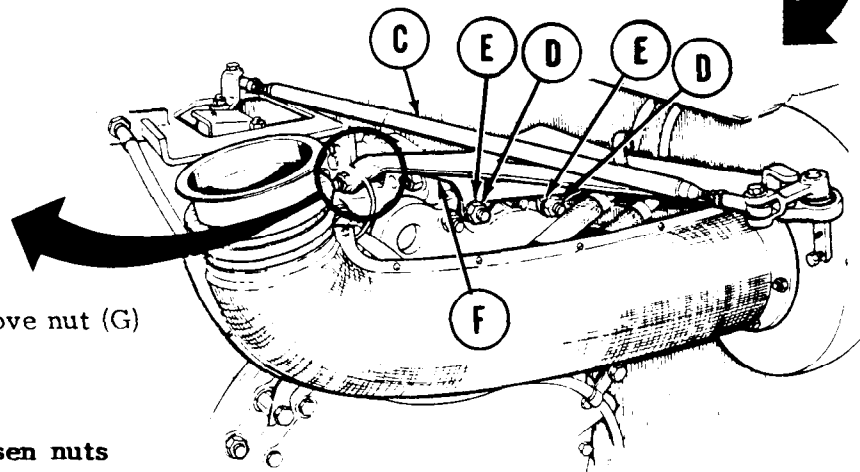

3. Using 3/4 inch wrench, remove nut (G) and washer (H).

NOTE

It may be necessary to loosen nuts and move stud back to remove bracket (F).

4. Remove bracket (F) and rod (C) as a unit.
5. Using 3/4 inch wrench, remove two lockwashers, nuts (J) and stud (K).

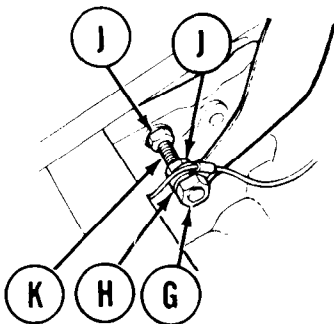

Go on to Sheet 3

TA108491

TRANSMISSION REPLACEMENT (Sheet 3 of 23)

6. Using two 9/16 inch wrenches, loosen nut (L).
7. Using pliers, remove cotter pin (M). Throw cotter pin away.
8. Using 9/16 inch wrench, remove nut (N) and washer (P) from stud.
9. Using pry bar, lift bracket (B) from stud.

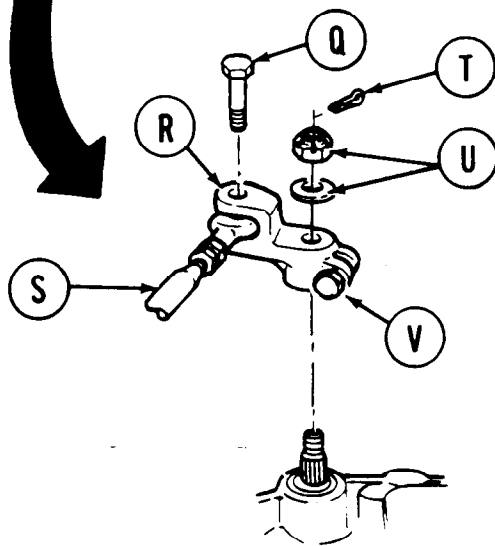
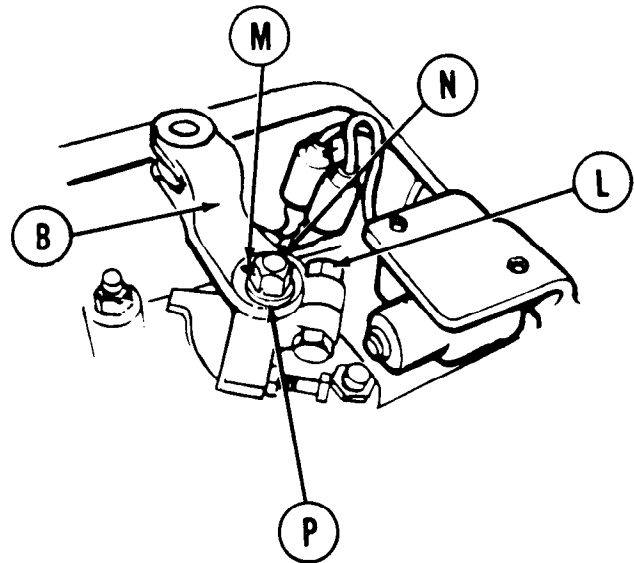
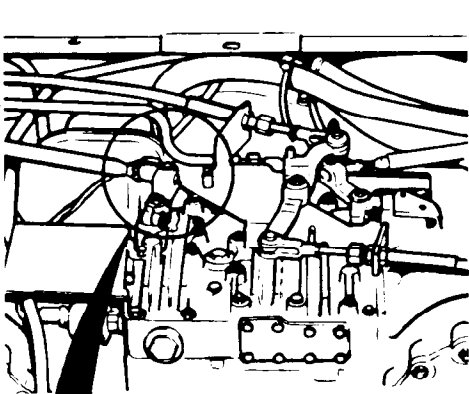

10. Using 9/16 inch socket, remove screw (Q) from lever (R). Remove rod (S) from lever (R).
11. Using pliers, remove cotter pin (T). Throw cotter pin away.
12. Using 9/16 inch socket, remove nut and washer (U).

13. Using two 9/16 inch wrenches, remove nut (V).
14. Using pry bar, lift lever (R) from shaft.

Go on to Sheet 4

TA108492

TRANSMISSION REPLACEMENT (Sheet 4 of 23)

15. Using 3/4 inch socket, remove two nuts and washers (W).
16. Using 3/4 inch wrench, remove screw and washer (X).
17. Remove bracket (Y) and rod (Z) from transmission as a unit.
18. Using 3/4 inch wrench, remove nut (AA).

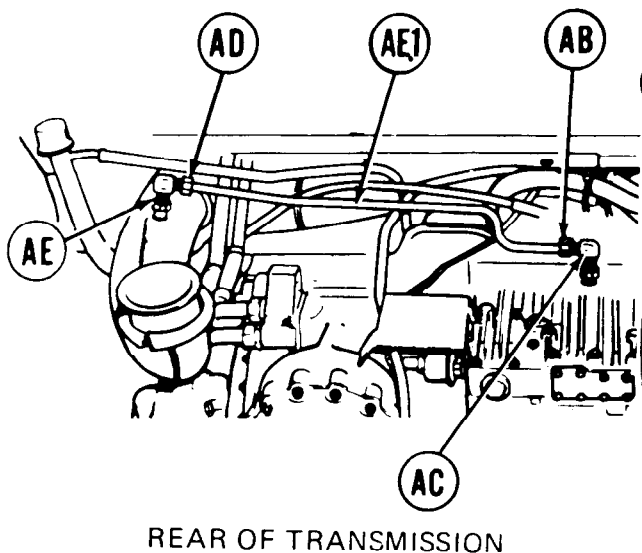
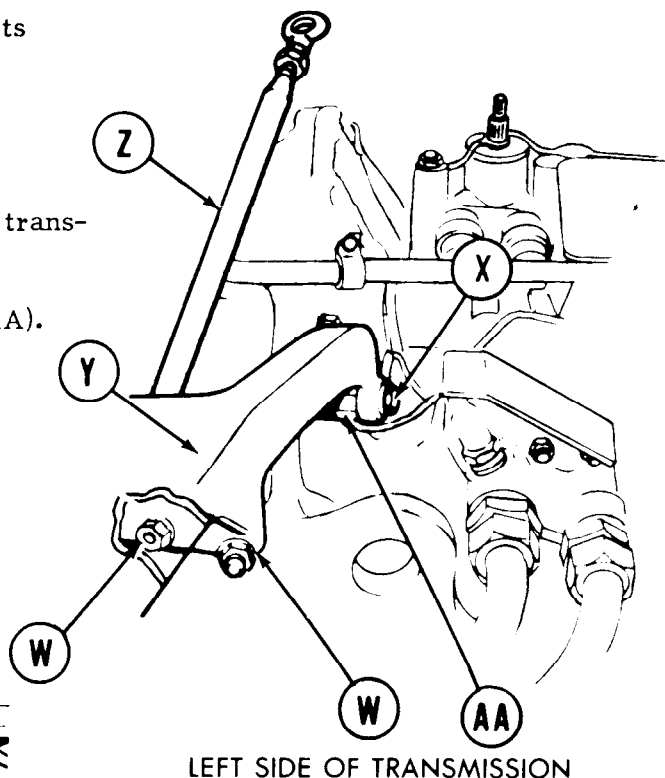

- 18.1. Using 7/8 inch wrench, disconnect nut (AB) from elbow (AC).
- 18.2. Using adjustable wrench, remove elbow (AC).

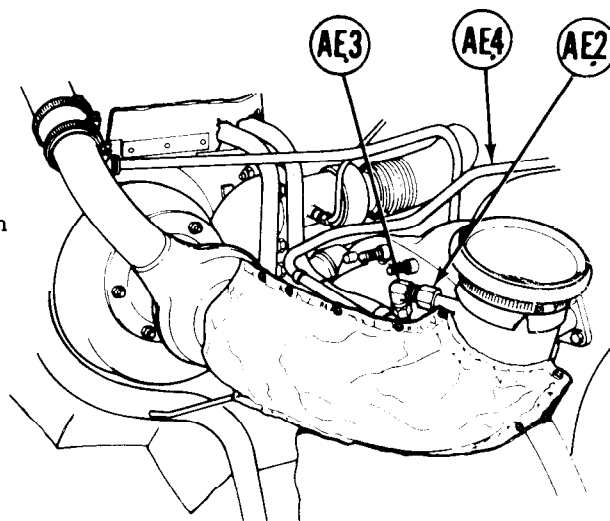

19. If transmission is mated to a 2D engine, use a 7/8 inch wrench and disconnect nut (AD) from elbow (AE). Remove transmission vent line (AE.1) from transmission.
20. If transmission is mated to a 2DA engine, use a 3/4 inch wrench and disconnect nut (AE.2) from elbow (AE.3). Remove transmission vent line (AE.4) from transmission.

Go on to Sheet 5

TRANSMISSION REPLACEMENT (Sheet 5 of 23)

21. Using screwdriver, loosen clamp (AF) and clamp (AG). Remove engine breather tube (AH).

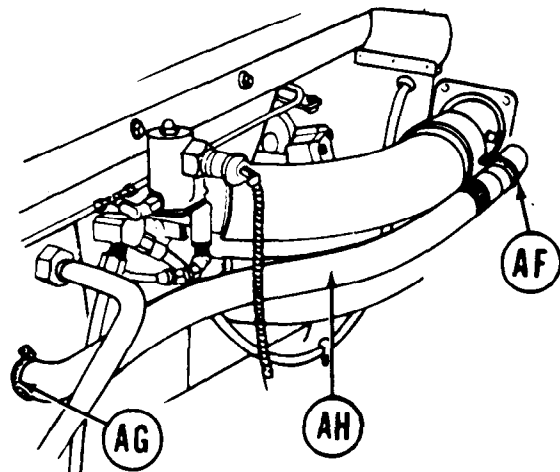

CENTER FRONT OF
TRANSMISSION

22. Using 9/16 inch socket and extension, remove six nuts (AJ) from left exhaust pipe flange (AK). Remove exhaust pipe (AL) and gasket (AM) from powerplant. Throw gasket away.
23. Using procedure described in step 22, remove right exhaust pipe.

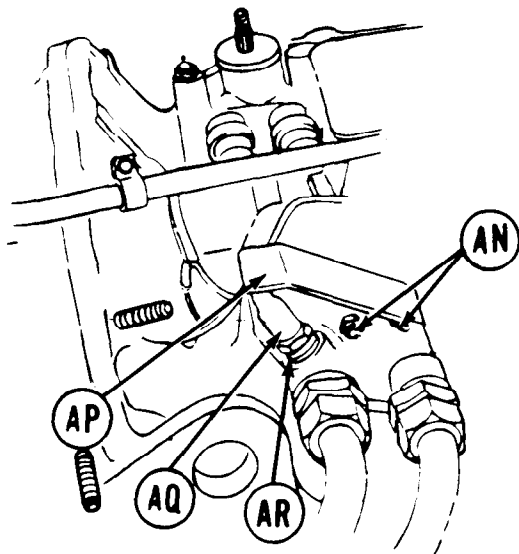
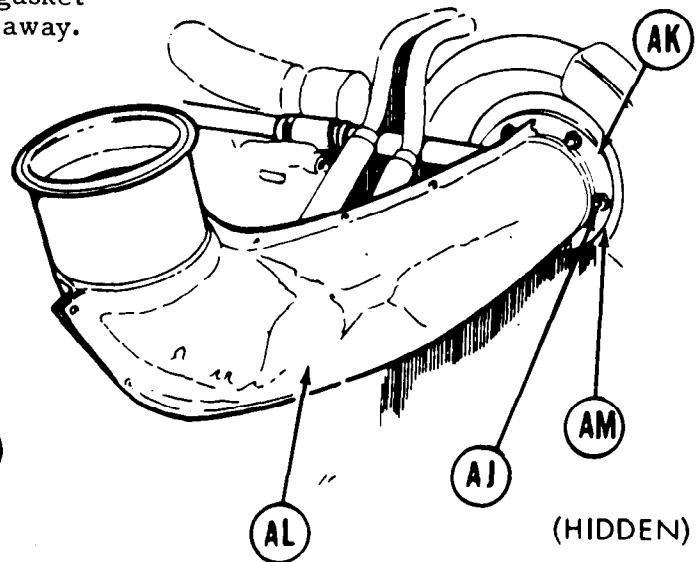

24. Using 9/16 inch socket and extension, remove two nuts (AN).
25. Remove protector (AP) from studs.

26. Unplug lead (AQ) from oil temperature transmitter (AR). Using 15/16 inch wrench, remove oil temperature transmitter (AR) from transmission and tag for proper installation.

Go on to Sheet 6

TRANSMISSION REPLACEMENT (Sheet 6 of 23)

27. Unplug lead (AS) from thermostatic switch (AT) on left side of transmission.
28. Using 15/16 inch wrench, remove switch (AT) from transmission and tag for proper installation.
29. Using 1-5/8 inch wrench to hold adapter (AU), use 1-1/2 inch wrench and remove two tubes (AV) from adapters (AU) on left side of transmission.
30. Using 1-5/8 inch wrench, remove two adapters (AU) and washers (AW) from adapter (AX).

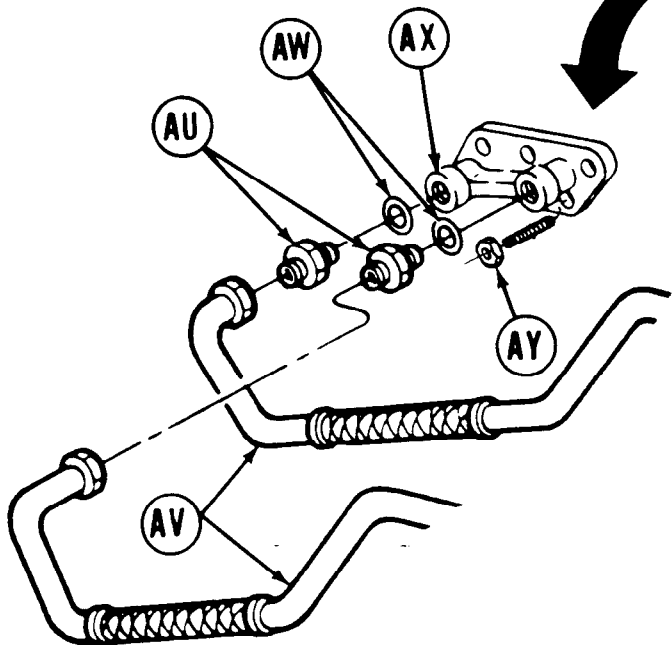
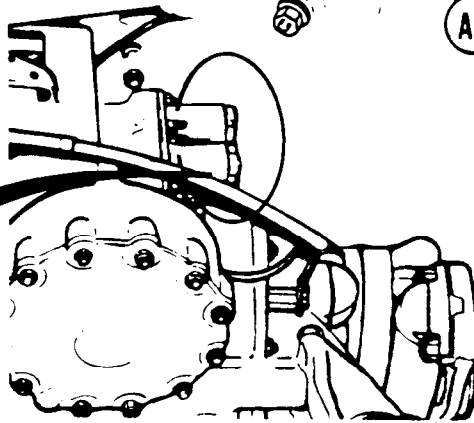
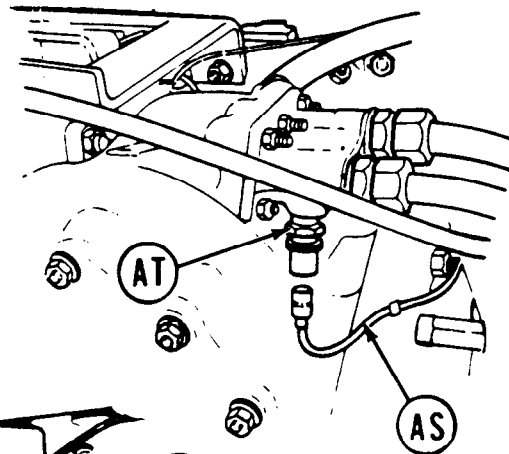

NOTE

It may be necessary to tap adapter (AX) with a hammer to loosen.

31. Using procedures described in steps 29 and 30, remove two tubes (AV), adapters (AU), and washers (AW) from adapter (AX) on the right side of transmission.
32. On right side of transmission, using 9/16 inch socket, remove six nuts (AY). Remove adapter (AX) from transmission.
33. On left side of transmission, using 9/16 inch socket, remove four nuts (AY). Remove adapter (AX) from transmission.

Go on to Sheet 7

TA108495

TRANSMISSION REPLACEMENT (Sheet 7 of 23)

34. Using 9/16 inch socket, remove two nuts (AZ) that secure plate (BA) to transmission.
35. Remove plate (BA) from transmission.
36. Unplug lead (BB) from oil pressure transmitter (BC).
37. Using 3/4 inch wrench to hold adapter (BD), use 7/8 inch wrench and remove oil pressure transmitter (BC) from adapter (BD).
38. Using 3/4 inch wrench, remove adapter (BD) from transmission.

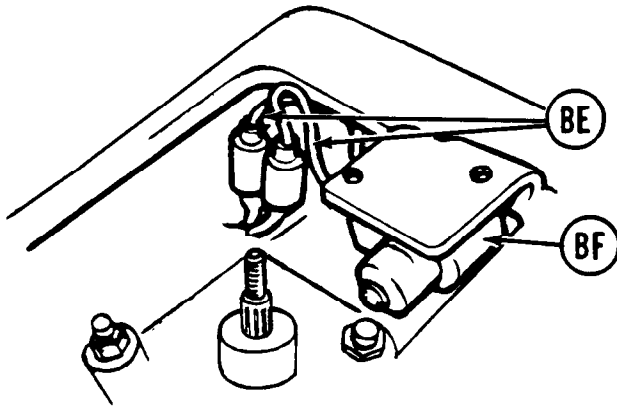
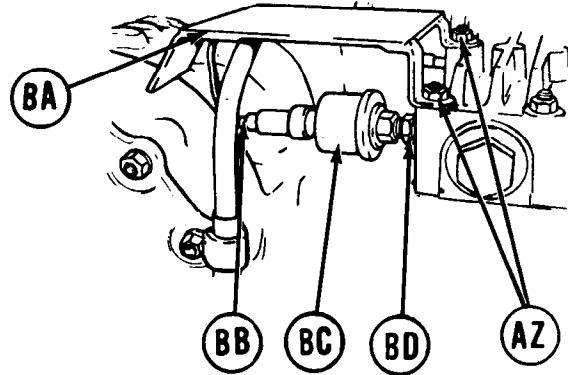

39. Unplug two leads (BE) from neutral shift switch (BF).

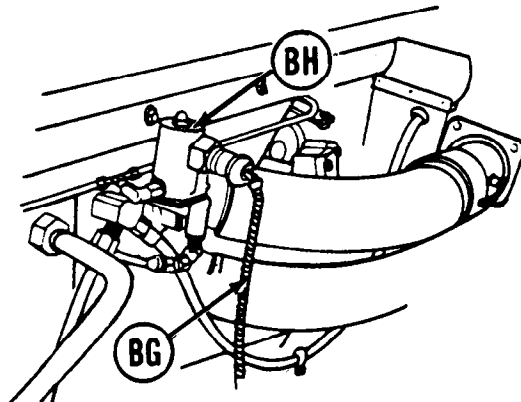

40. Using hand, unscrew lead (BG) from engine fuel solenoid (BH).
41. Remove transmission wiring harness (TM 5-5420-226-20).
42. Remove brake control assembly (TM 5-5420-226-20).
43. Remove brake bellcrank assembly (TM 5-5420-226-20).
44. Remove left brake lever assembly (TM 5-5420-226-20).
45. Remove right brake lever assembly (TM 5-5420-226-20).
46. Remove brake tube quick-disconnect (TM 5-5420-226-20).

Go on to Sheet 8

TA108496

TRANSMISSION REPLACEMENT (Sheet 8 of 23)

47. Remove left brake housing assembly (TM 5-5420-226-20).
48. Remove right brake housing assembly (TM 5-5420-226-20).
49. Remove left and right brake slave cylinder assemblies and tubes (TM 5-5420-226-20).
50. Remove left and right universal joint assemblies (TM 5-5420-226-20).
51. Remove left and right transmission mount assemblies (TM 5-5420-226-20).
52. Remove fuel return line (TM 5-5420-226-20).
53. Drain oil from transmission (TM 5-5420-226-20).
54. Using hose clamp pliers, remove two hose clamps (BJ) and hose (BK) from tube (BL).
55. Using 3/4 inch socket, remove two nuts (BM) that secure tube and bracket assembly (BN) to transmission.
56. Using 1/2 inch socket, remove six nuts (BP) and washers (BQ).
57. Remove gasket (BR), strainer (BS), gasket (BT), and tube (BN) from transmission. Throw gaskets (BR and BT) away.

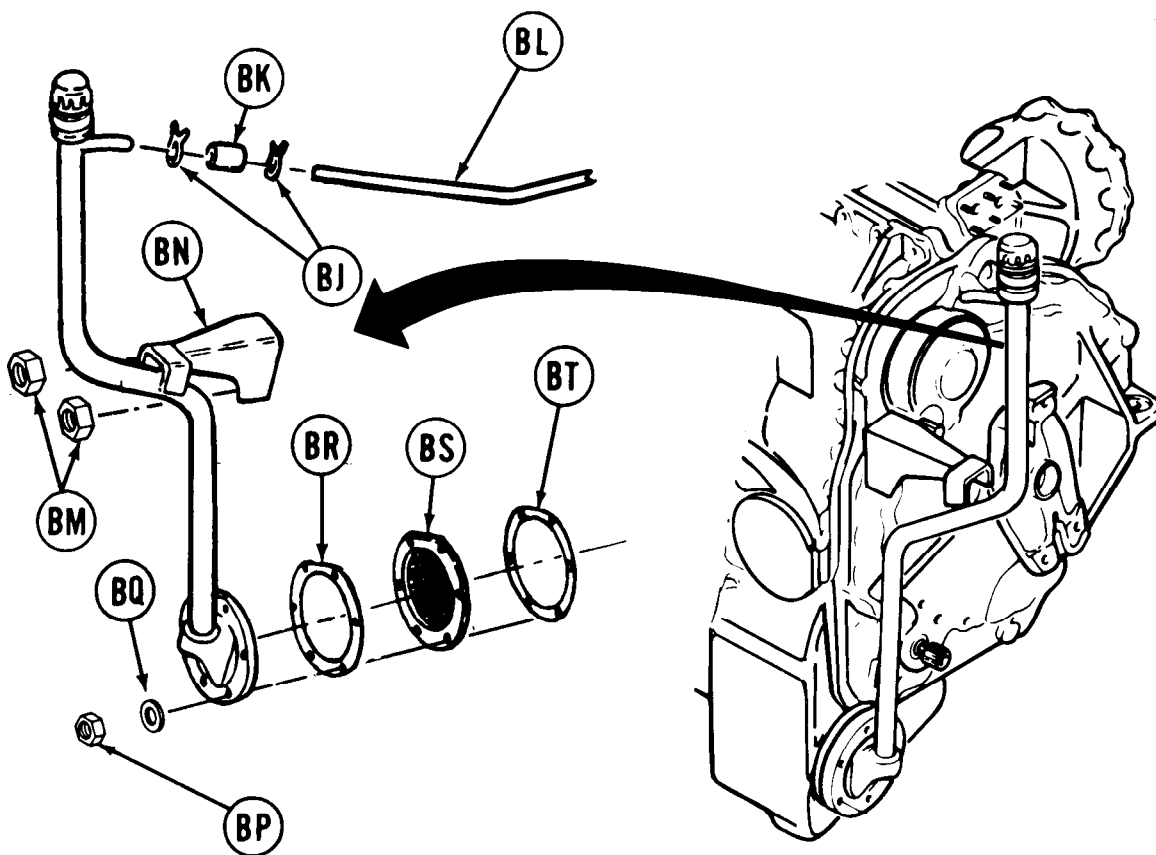

Go on to Sheet 9

TA108497

TRANSMISSION REPLACEMENT (Sheet 9 of 23)

58. Using 1-1/8 inch socket, remove input shaft plug (BU) and gasket (BV) from transmission.

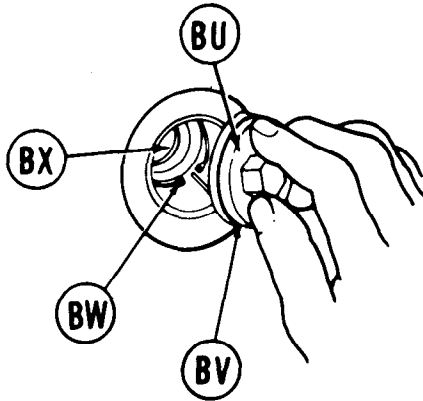
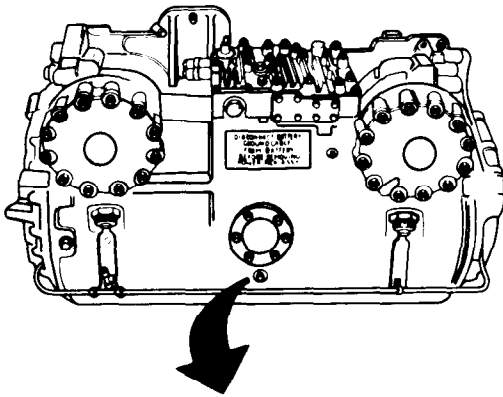

59. Using snap ring pliers, remove retaining ring (BW) at rear of input shaft (BX).

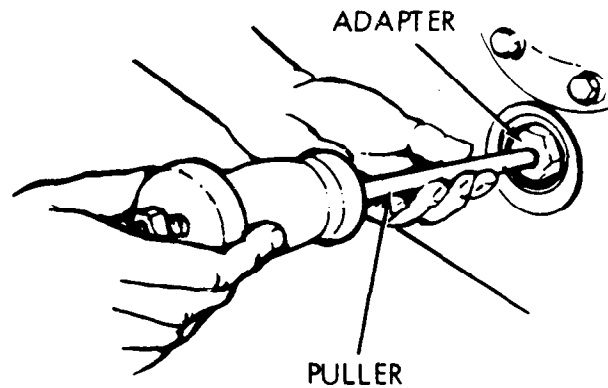

60. Using puller (Item 3, Chapter 2, Section I) and adapter (Item 2, Chapter 2, Section I), draw the input shaft (BZ) rearward until it is disengaged from the engine drive connection.

61. Attach transmission sling (Item 4, Chapter 2, Section I) to transmission. Take up slack but do not lift transmission.

62. Place a pan under engine and transmission at separation point to catch oil.

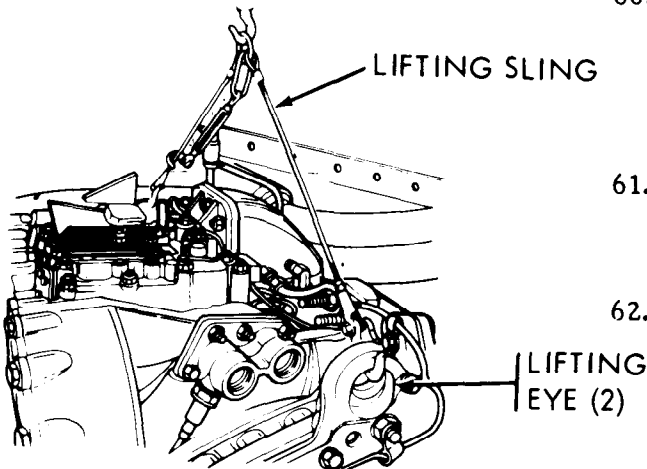

Go on to Sheet 10

TA108498

TRANSMISSION REPLACEMENT (Sheet 10 of 23)

- 63. Using fabricated wrench (Fig. D-1, Appendix D) and 5/8 inch socket, remove screw (BY), nut (BZ), and washer (CA) from left and right side of transmission.
- 64. Using fabricated wrench, remove 17 screws (CB), lockwashers (CC), and washers (CD) that secure transmission to engine.
- 65. Carefully move transmission rearward to separate from engine.

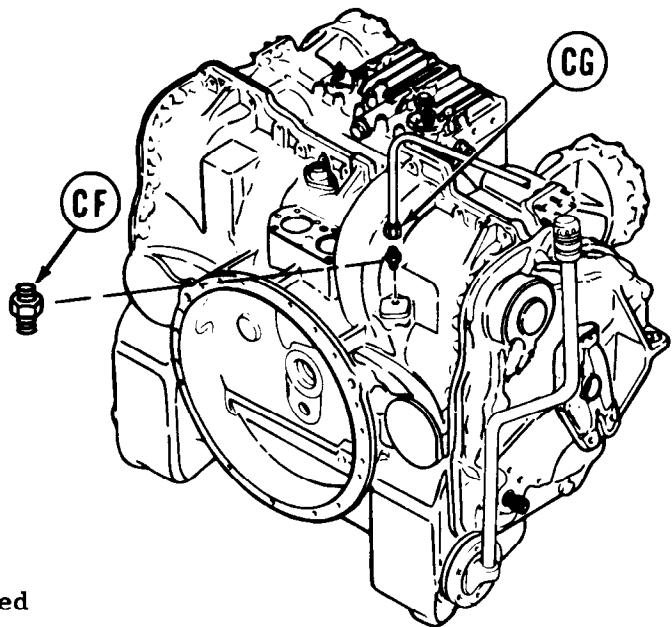
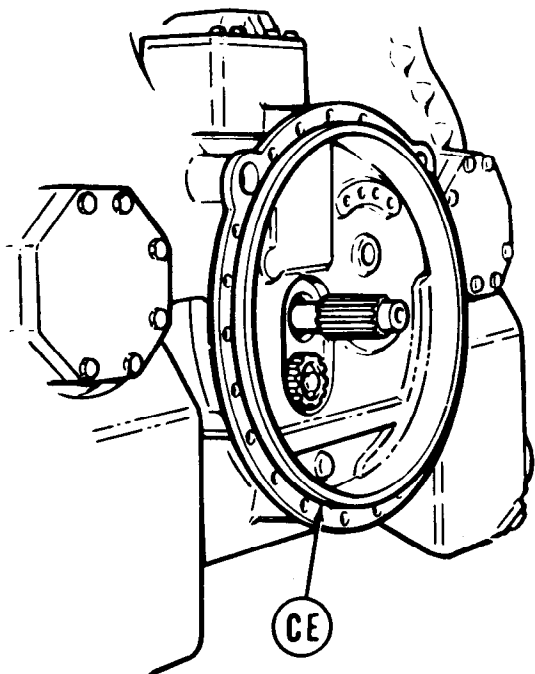
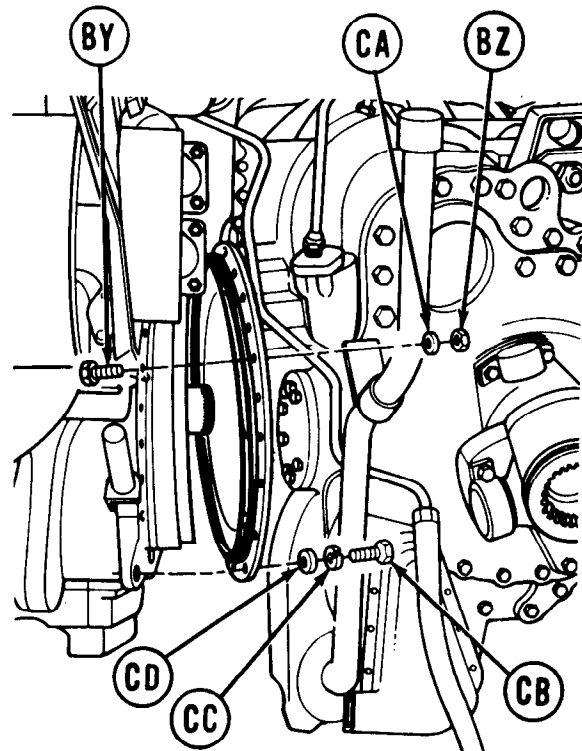

- 66. Remove transmission-to-engine preformed packing (CE) and throw it away.
- 67. Using 3/4 inch wrench to hold adapter (CF), use 7/8 inch wrench to remove nut (CG).
- 68. Using 3/4 inch wrench, remove adapter (CF) from transmission.

Go on to Sheet 11

TA108499

TRANSMISSION REPLACEMENT (Sheet 11 of 23)**CLEANING:**

1. Wearing rubber gloves, clean all parts that have been removed from transmission with dry cleaning solvent (Item 12, Appendix B). Wipe dry with clean lint-free rags.
2. Using putty knife, clean all gasket material from area where gaskets were removed.

INSTALLATION:

1. Using transmission sling (Item 4, Chapter 2, Section I) and a suitable hoist, remove replacement transmission from container.
2. Remove shipping caps, plugs, covers, and mounts from replacement transmission as components are installed and install them on unserviceable transmission.
3. Using 3/4 inch wrench, install adapter (A) on transmission.
4. Using 3/4 inch wrench to hold adapter (A), use 7/8 inch wrench on nut (B) to secure tube (C) to adapter (A).
5. Position new preformed packing (D), to transmission mounting flange.

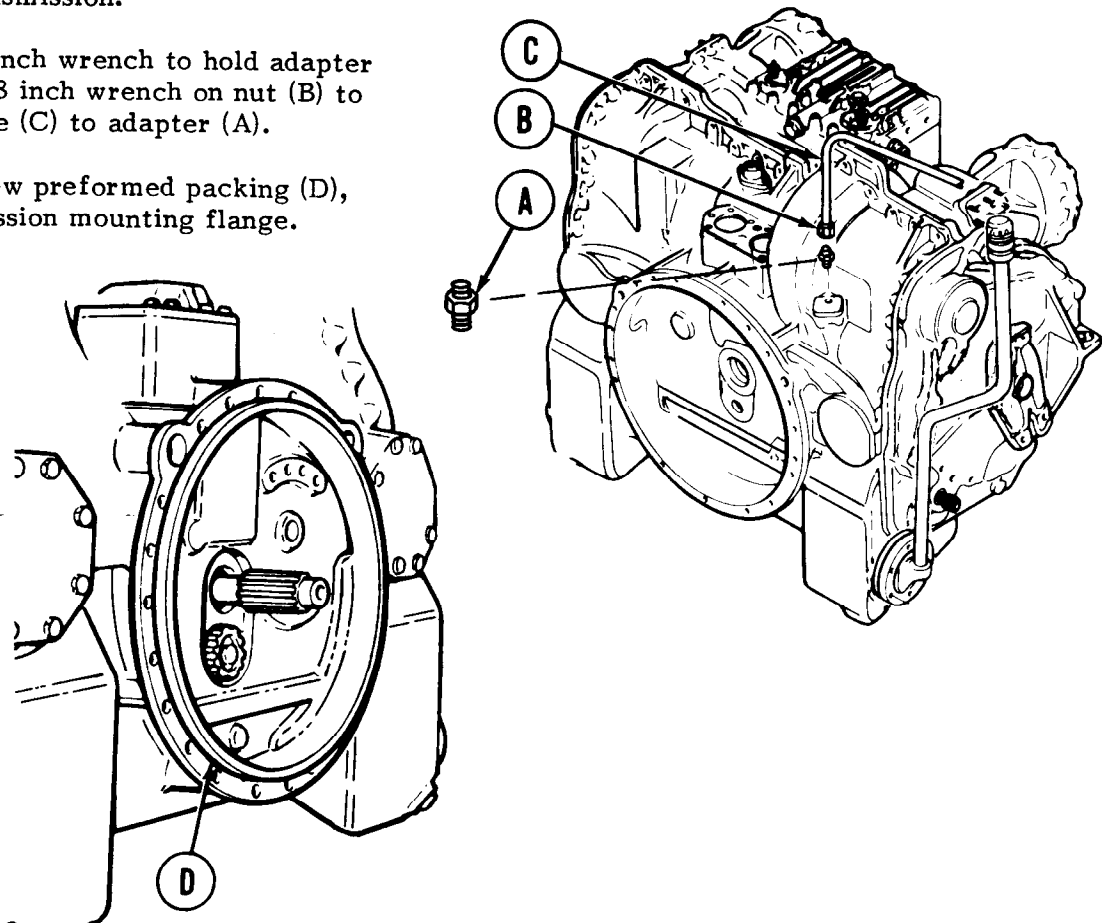
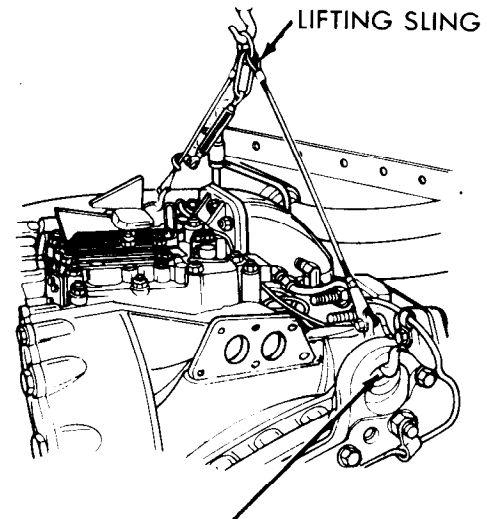

Go on to Sheet 12

TA108500

TRANSMISSION REPLACEMENT (Sheet 12 of 23)

6. Using 1-1/8 inch socket, remove input shaft plug (E) and gasket (F) from transmission.

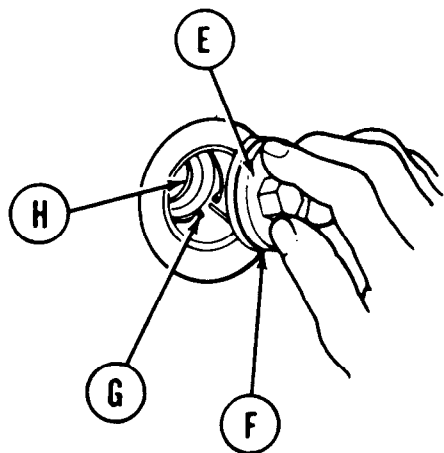
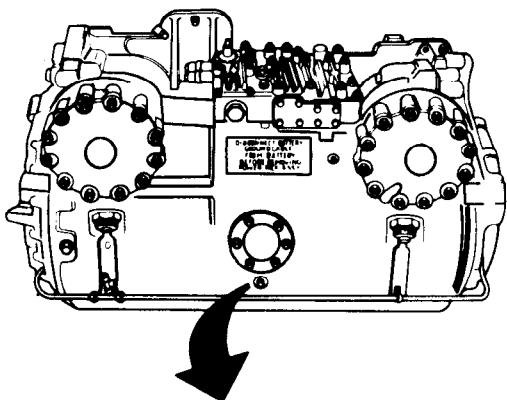

7. Using snap ring pliers, remove retaining ring (G) at rear of input shaft (H).

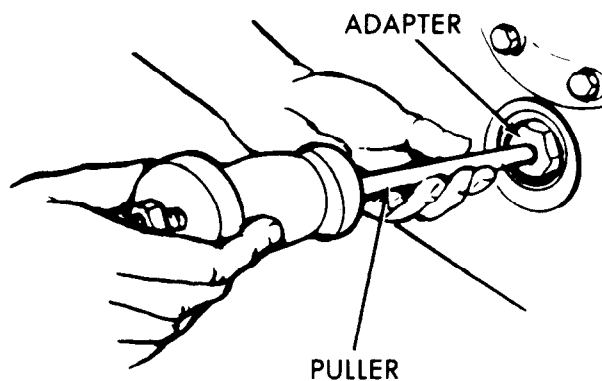

8. Using puller (Item 3, Chapter 2, Section I) and adapter (Item 2, Chapter 2, Section I), draw the input shaft (H) rearward.

Go on to Sheet 13

TA108501

TRANSMISSION REPLACEMENT (Sheet 13 of 23)

CAUTION

When mating transmission to engine, be sure to position electrical wiring aside to prevent wiring from being caught between mounting surfaces.

9. Aline transmission with dowel pins attached to engine, and carefully advance transmission onto dowel pins until transmission mounting flange is in contact with engine transmission adapter.
10. Using fabricated wrench and 5/8 inch socket, install screw (J), washer (K), and nut (L) on left and right side of transmission.
11. Using fabricated wrench or 5/8 inch wrench, install 17 screws (M), lockwashers (N), and flat washers (P) that secure transmission to engine (Q).
12. Remove lifting sling from transmission.

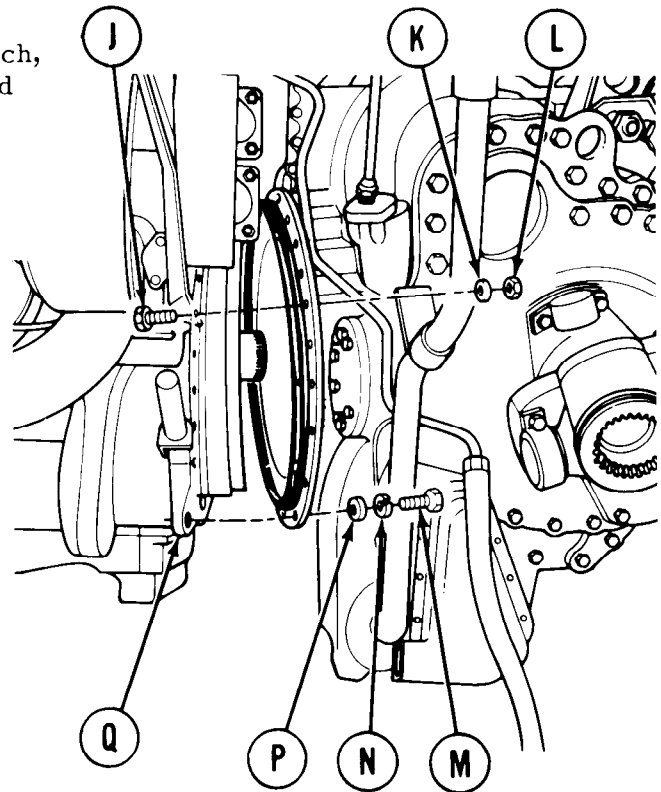
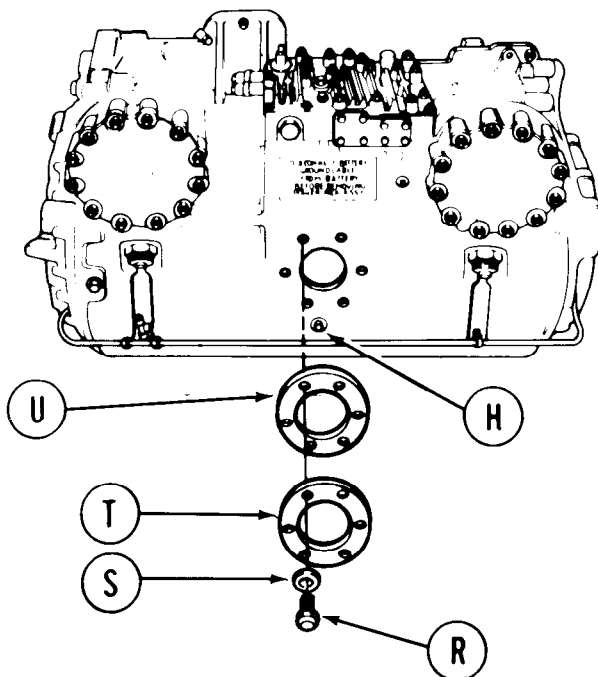

13. Push transmission input shaft (H) into transmission. If engine and transmission splines do not aline, use 5/8 inch socket to remove six power takeoff cover screws (R) and lockwasher (S). Remove cover (T) and gasket (U).

Go on to Sheet 14

TRANSMISSION REPLACEMENT (Sheet 14 of 23)

14. Using pinion turning wrench, turn transmission until splines aline and shaft (H) will slide in and seat properly.
15. Remove pinion turning wrench.
16. Using snap ring pliers, install retaining ring (G) on input shaft (H).

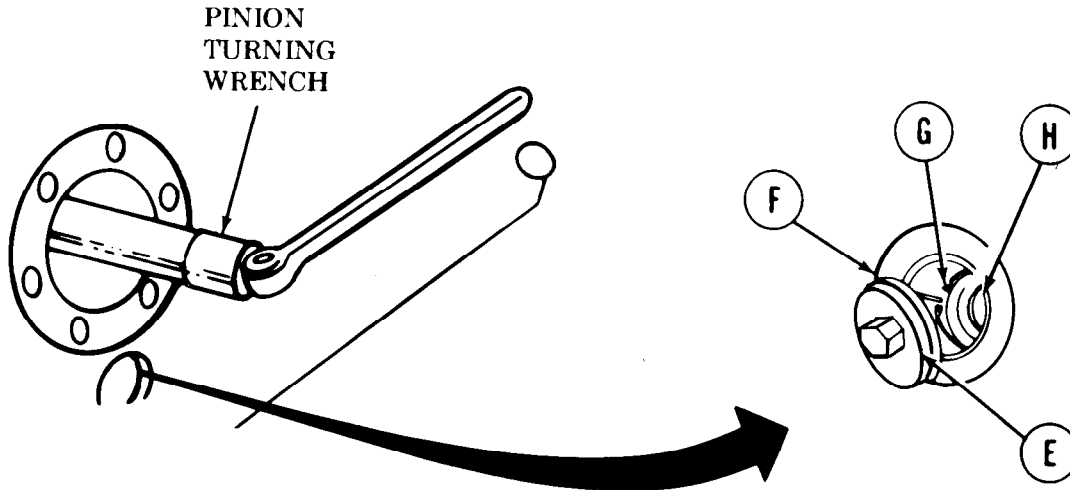

17. Position gasket (F) onto plug (E) and, using 7/8 inch socket and torque wrench, tighten plug (E) to 50-60 lb-ft (68-81 N·m).
18. Position power takeoff gasket (U) and cover (T) on transmission housing and, using 5/8 inch socket, install six screws (R) and washers (S).

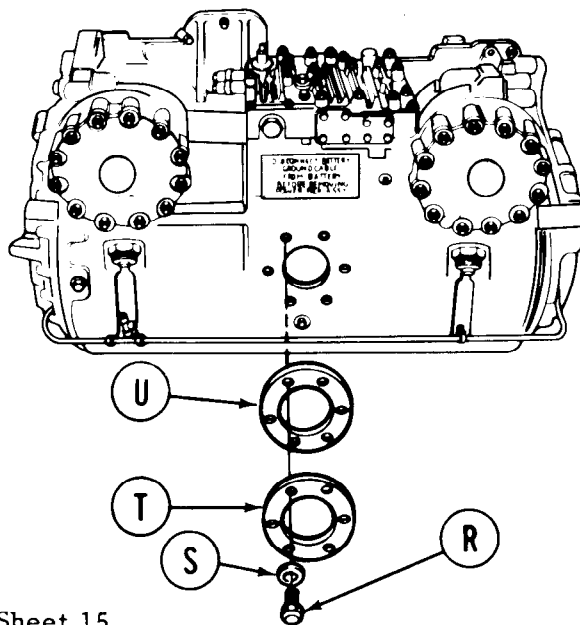

19. Install or connect transmission wiring harness (TM 5-5420-226-20).

Go on to Sheet 15

TRANSMISSION REPLACEMENT (Sheet 15 of 23)

20. Install left and right transmission mount assemblies (TM 5-5420-226-20).
21. Install left and right universal joint assemblies (TM 5-5420-226-20).
22. Install left and right brake housing assemblies (TM 5-5420-226-20).
23. Install left and right brake lever assemblies (TM 5-5420-226-20).
24. Install left and right brake slave cylinder assemblies and tube (TM 5-5420-226-20).
25. Install brake tube quick-disconnect and hose (TM 5-5420-226-20).
26. Install brake bellcrank assembly (TM 5-5420-226-20).
27. Install brake control assembly (TM 5-5420-226-20).
28. Install engine fuel return tube assembly (TM 5-5420-226-20).

Go on to Sheet 16

TRANSMISSION REPLACEMENT (Sheet 16 of 23)

29. Position gasket (V), strainer (W), gasket (X), and tube and bracket assembly (Y) onto six studs located on bottom left side of transmission.
30. Using 1/2 inch socket, install six nuts (Z) and washers (AA) securing tube and bracket assembly (Y) to transmission.
31. Using 3/4 inch socket, install two nuts (AB) securing tube and bracket assembly (Y) to transmission.

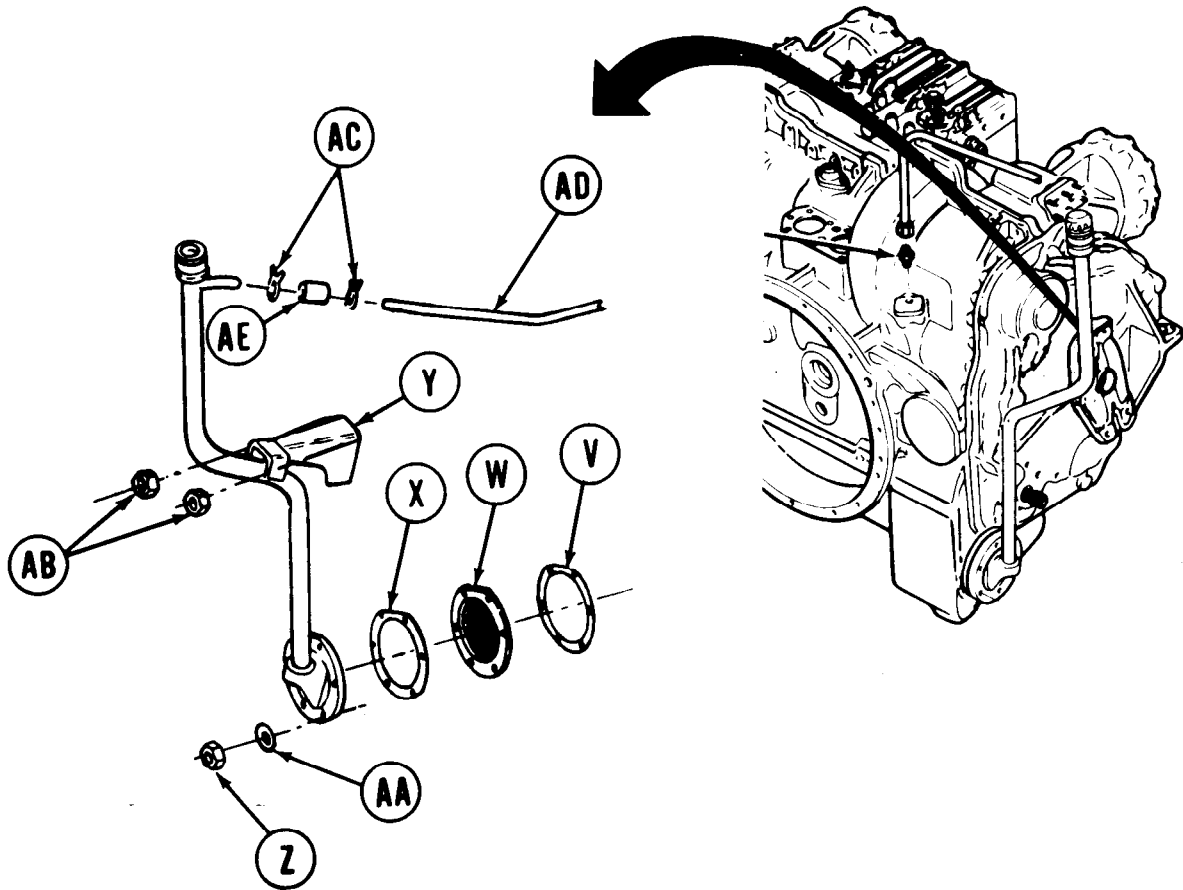

32. Position hose clamps (AC) onto tube assembly (Y) and tube (AD). Install hose (AE) onto tube assembly (Y) and tube (AD). Using hose clamp pliers, position clamps (AC) to secure hose (AE) to tube assembly (Y) and tube (AD).

Go on to Sheet 17

TA108504

TRANSMISSION REPLACEMENT (Sheet 17 of 23)

NOTE

Adapter (AG) must be positioned properly. Left side adapter has hole for thermostatic switch which is angled downward. Right side adapter has threaded hole of oil temperature sensor angled upward.

33. On right side of transmission position gasket (AF) and adapter (AG) on studs.
34. Using 9/16 inch socket and ratchet, install six nuts (AH) on studs.
35. On left side of transmission, position gasket (AF) and adapter (AG) onto studs.
36. Using 9/16 inch socket, install four nuts (AH) onto studs. Do not install nuts on two studs located at top of adapter (AG) on left side.

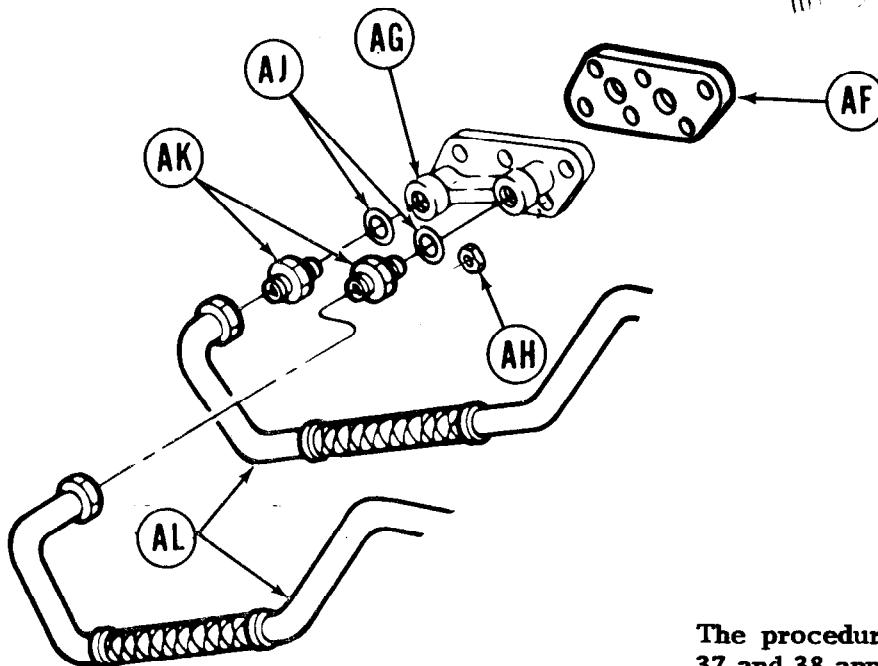
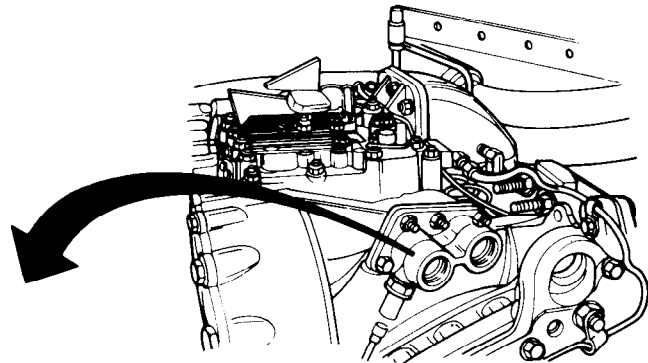

NOTE

The procedures described in steps 37 and 38 apply to the left and right side of transmission.

37. Position washer (AJ) onto adapter (AK) and, using 1-5/8 inch wrench, install adapters (AK) into adapters (AG).
38. Using 1-1/2 inch wrench, install tubes (AL) onto adapters (AK).

Go on to Sheet 18

TA108505

TRANSMISSION REPLACEMENT (Sheet 18 of 23)

39. Using 15/16 inch wrench, install thermostatic switch (AM) into adapter (AG) on left side of transmission.
40. Connect connector (AN) to thermostatic switch (AM).
41. Using 15/16 inch wrench, install oil temperature transmitter (AP) into adapter (AG) on right side of transmission.

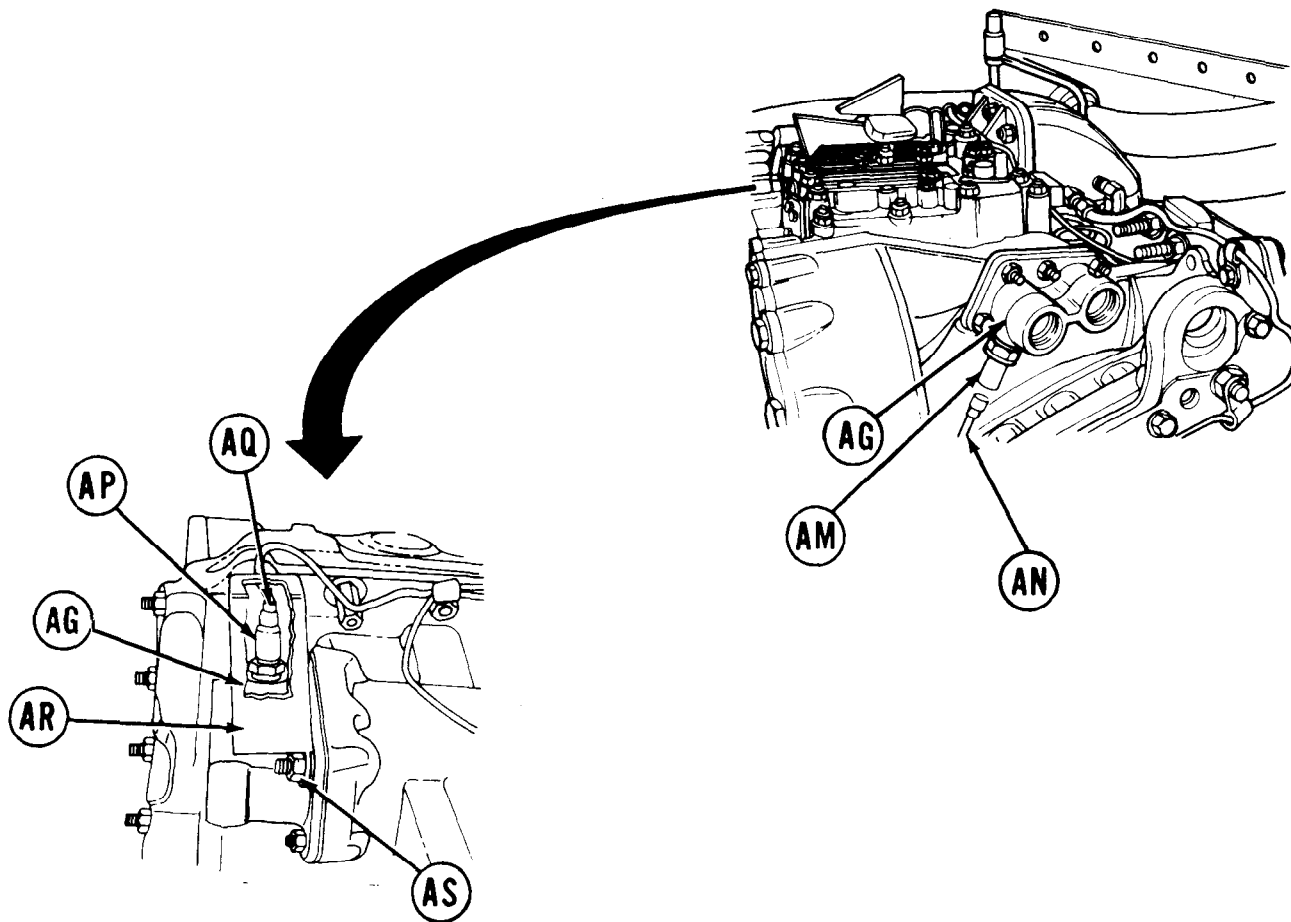

42. Connect connector (AQ) to oil temperature transmitter (AP).
43. Position protector (AR) onto studs and, using 9/16 inch socket, install two nuts (AS) securing protector (AR) and adapter (AG).

Go on to Sheet 19

TA108506

TRANSMISSION REPLACEMENT (Sheet 19 of 23)

44. Using hand, install lead (AT) onto engine fuel solenoid (AU).

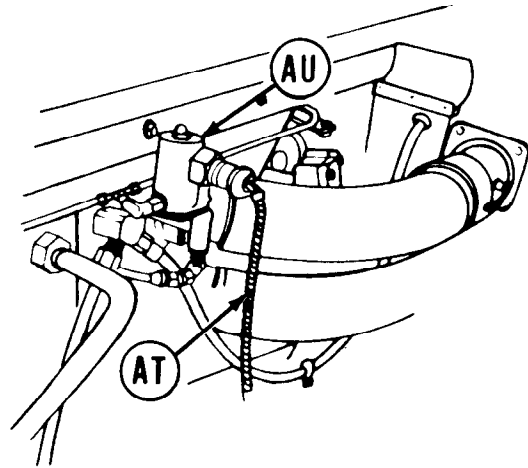
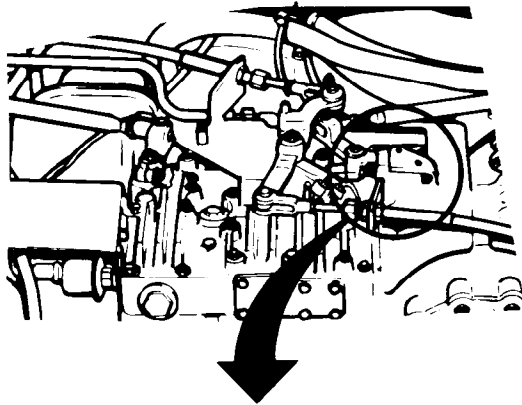

45. Using hand, plug two leads (AV) into neutral shift switch (AW).

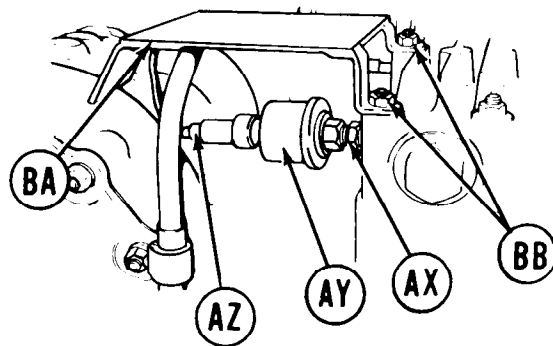
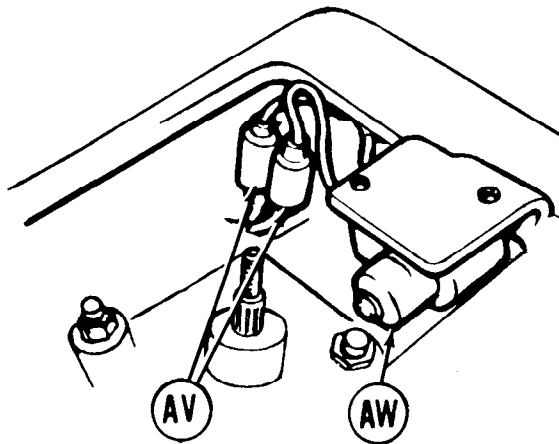

46. Using 3/4 inch wrench, install adapter (AX) into transmission.
47. Using 7/8 inch wrench, install oil pressure transmitter (AY) into adapter (AX).
48. Using hand, plug lead (AZ) onto transmitter (AY).
49. Position plate (BA) onto transmission and, using 9/16 inch socket and ratchet, install two nuts (BB) to hold mounting plate (BA) to transmission.

Go on to Sheet 20

TA108507

TRANSMISSION REPLACEMENT (Sheet 20 of 23)

NOTE

The procedure described in step 50 applies to the right and left side exhaust pipes.

- 50. Position gasket (BC) and exhaust pipe (BD) onto turbocharger (BE) and, using 9/16 inch socket, install six nuts (BF) securing exhaust pipe to turbocharger.

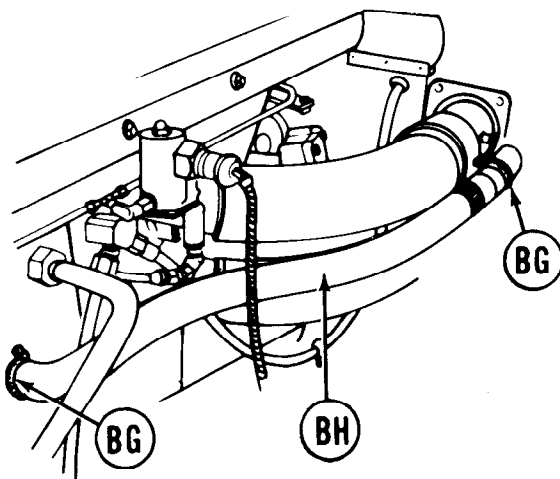
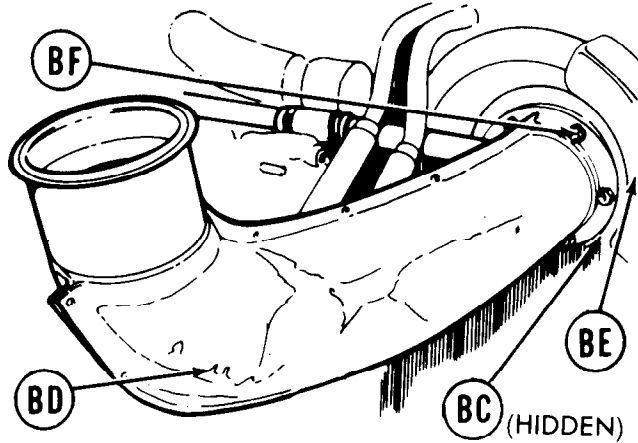

- 51. Install clamps (BG) onto engine breather tube and position tube onto engine and exhaust mounts. Using screwdriver, tighten clamps (BG) securing tube (BH) to mounts.

- 52. Position transmission vent line (BJ) onto transmission and using 7/8 inch wrench, install line by tightening connecting nut (BK) and connecting nut (BL).

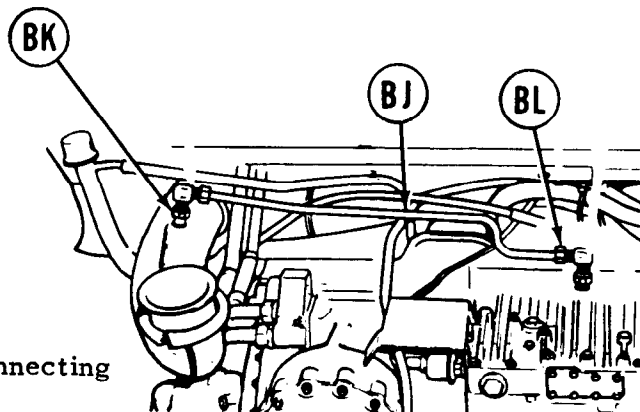

Go on to Sheet 21

TA108508

TRANSMISSION REPLACEMENT (Sheet 21 of 23)

53. Install nut (BM) on stud.
54. Position bracket (BN) and rod (BP) onto transmission. Using 3/4 inch wrench install screw (BQ) through washer (BR), bracket (BN), and into nut (BM).
55. Using 3/4 inch socket, install two nuts (BS) and washers (BT) onto studs.

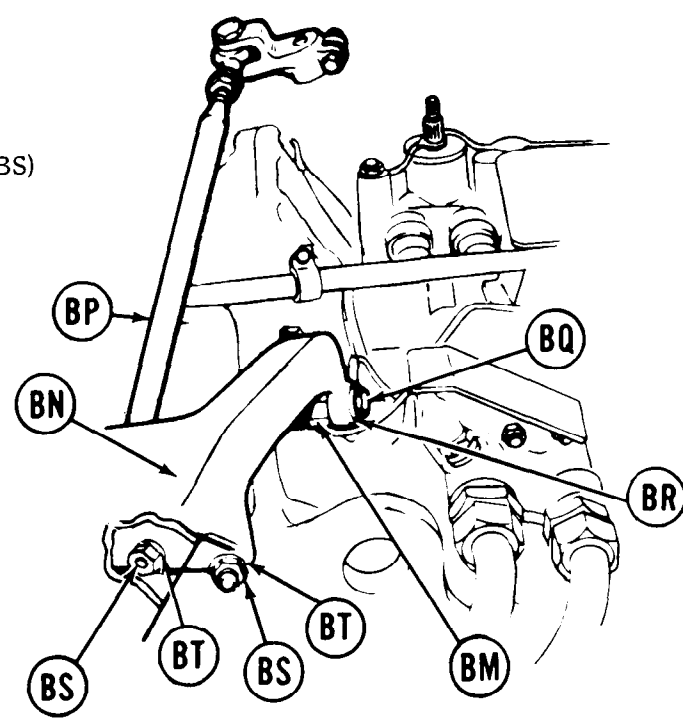
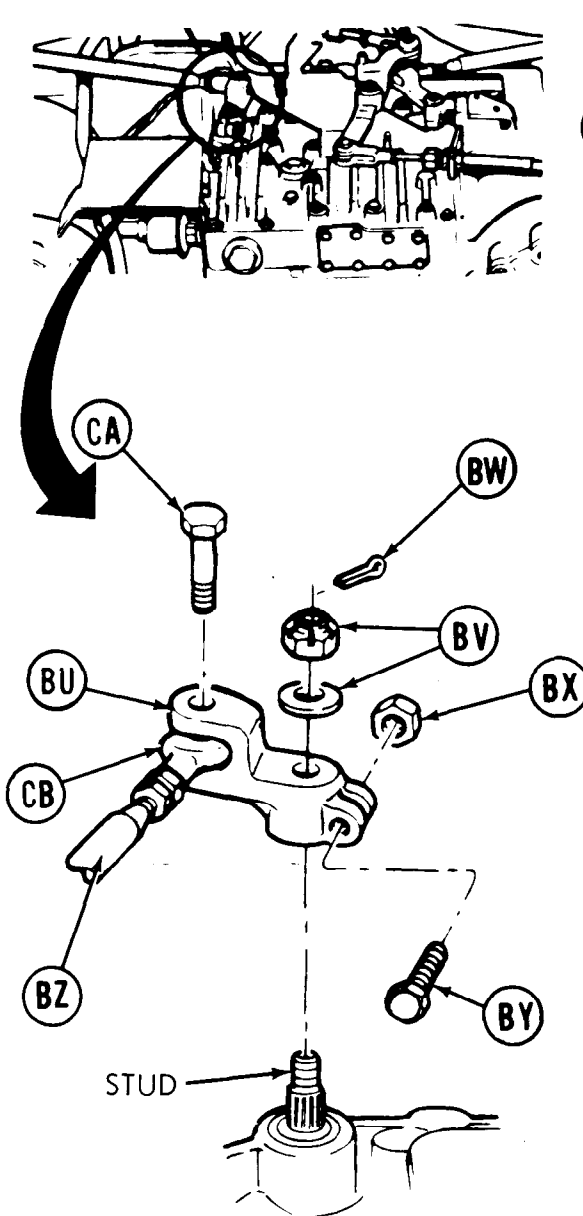

NOTE

Make sure to align lever (BU) with slot on shaft.

56. Position lever (BU) onto stud. Using 9/16 inch socket and ratchet, install nut and washer (BV) onto stud.
57. Using pliers, install new cotter pin (BW) through stud.
58. Using two 9/16 inch wrenches, tighten nut (BX) and screw (BY).
59. Position rod (BZ) into lever (BU) and, using 9/16 inch socket, install screw (CA) through lever (BU) and rod end (CB).

Go on to Sheet 22

TA108509

TRANSMISSION REPLACEMENT (Sheet 22 of 23)

60. Position bracket (CC) onto stud and, using 9/16 inch wrench, install nut and washer (CD) onto stud.
61. Using pliers, install new cotter pin (CE) through stud.
62. Using two 9/16 inch wrenches, tighten screw (CF) and nut (CG).

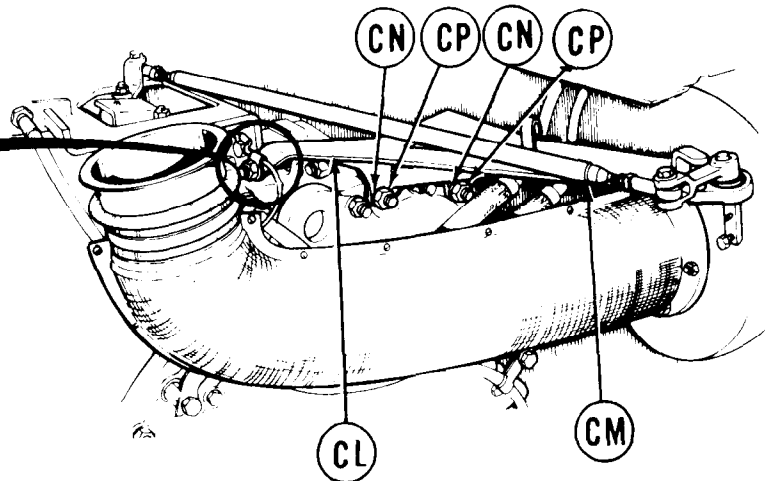
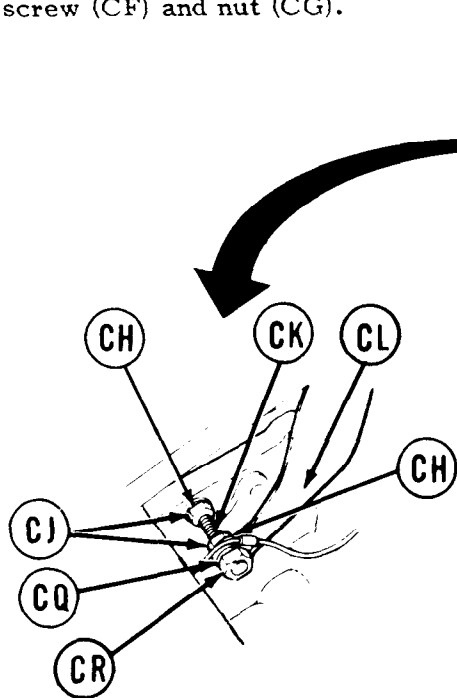
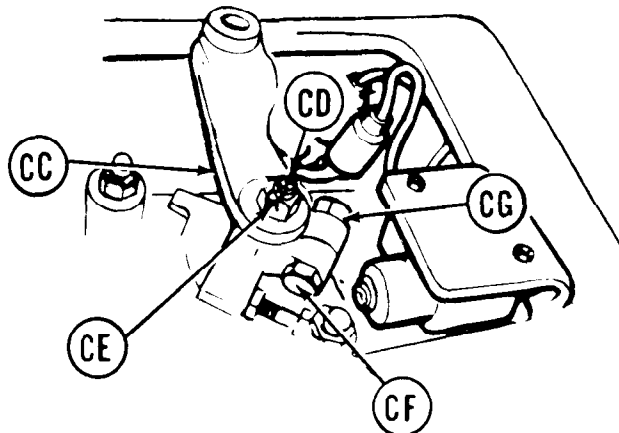

63. Install two washers (CH), two nuts (CJ), and stud (CK) onto transmission.
64. Install stud (CK) far enough back into transmission to be able to install bracket (CL).
65. Position bracket (CL) and rod (CM) onto transmission as a unit.

66. Using 3/4 inch socket, install two washers (CN) and nuts (CP) securing bracket to transmission.
67. Adjust stud (CK) to permit installation of washer (CQ) and nut (CR). Using 3/4 inch socket and ratchet, install washer (CQ) and nut (CR).
68. Using 3/4 inch socket and wrench, tighten nuts (CJ) up against transmission and bracket.

Go on to Sheet 23

TA108510

TRANSMISSION REPLACEMENT (Sheet 23 of 23)

69. Position rod (CS) into bracket (CC) and, using 9/16 inch wrench, install screw (CT) through bracket (CC) and rod end (CU).
70. Fill transmission with oil (LO 5-5420-226-12).
71. Adjust parking brake control cables (TM 5-5420-226-20).
72. Install engine shroud and supports (TM 5-5420-226-20).
73. Install powerplant (TM 5-5420-226-20).

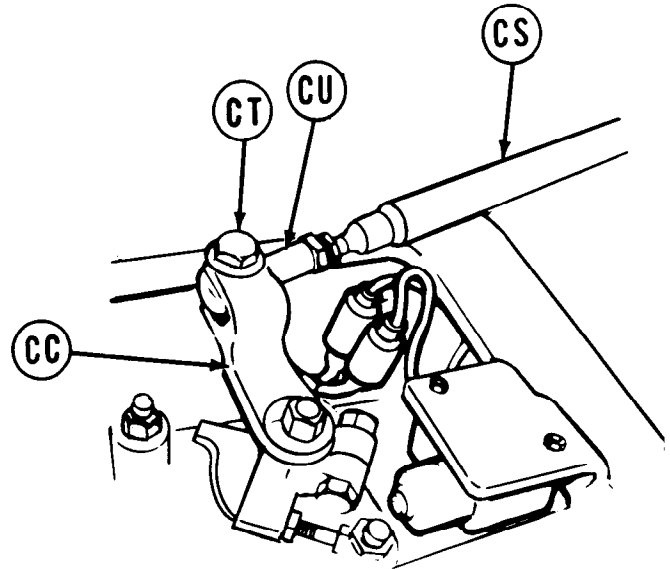

End of Task

TA108511

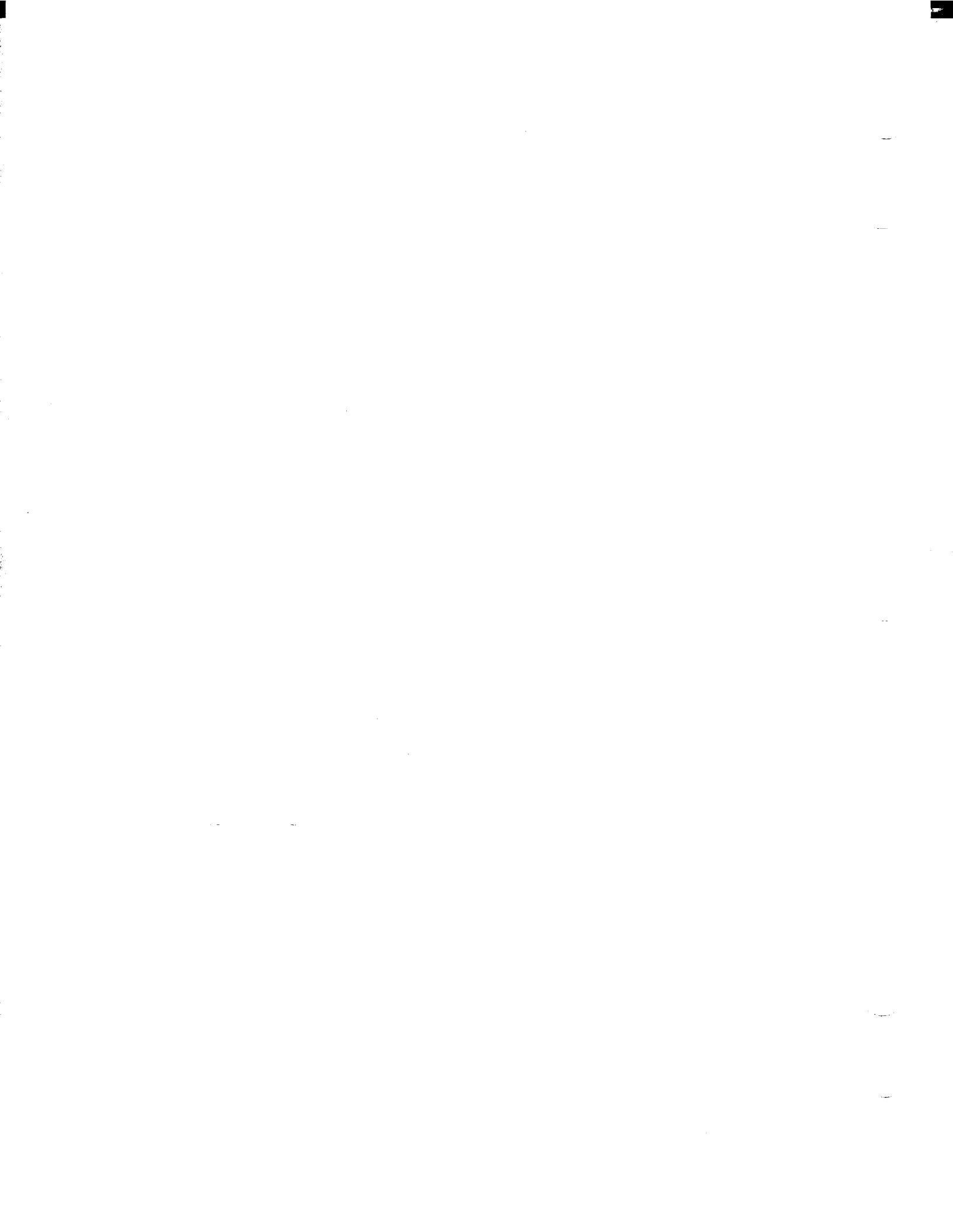

CHAPTER 7

FINAL DRIVE MAINTENANCE

FINAL DRIVE REPAIR (Sheet 1 of 30)

PROCEDURE INDEX

PROCEDURE	PAGE
Disassembly	7-3
Assembly	7-18
Axial Play and Backlash Tests	7-29

- TOOLS:**
- 3/16 in. socket head screw key (allen wrench)
 - 5/8 in. socket head screw key (allen wrench)
 - 5/16 in. socket head screw key (allen wrench)
 - Lifting device (2000 lb capacity)
 - 3/4 in. socket with 1/2 in. drive
 - 1 in. socket with 1/2 in. drive
 - Ratchet with 1/2 in. drive
 - 7/16 in. combination box and open end wrench
 - Diagonal cutting pliers
 - 7/8 in. socket with 1/2 in. drive
 - Brass drift
 - Dial indicator (5120-00-227-8840)
 - Chisel
 - Putty knife
 - C-clamp (3 in. min.) (2 required)
 - Micrometer depth gage (5210-00-619-4045)
 - 5 in. extension with 1/2 in. drive
 - Hammer
 - 3/4 in. combination box and open end wrench
 - Arbor press
 - Torque wrench with 3/4 in. drive (0-600 lb-ft) (0-813 N.m)
 - 3/4 in. crowfoot wrench with 1/2 in. drive
 - Torque wrench (PD 1201)
 - 6 in. steel rule
 - Micrometer set (inside)
 - Micrometer set (outside)
 - Drain pan
 - Hinged bar with 1/2 in. drive
 - Pry bar (2 required)
 - Inspection mirror (5120-00-448-2455)
 - Crowbar
 - Parallel straight bar (5220-00-501-7462)
 - Stud remover and setter (5120-00-596-0980)
 - Mechanical puller kit (5120-00-423-1596)
 - Mechanical puller kit (5120-00-313-9496)
 - Torque wrench reactor bar (5120-01-008-3632)

- SPECIAL TOOLS:**
- Seal inserter (Item 8, Chapter 2, Section I)
 - Box wrench (Item 6, Chapter 2, Section I)
 - Bearing removal tool (Item 7, Chapter 2, Section I)

- FABRICATED TOOLS:**
- Bearing installer (Figure D-4, Appendix D)
 - Output shaft lifting attachment (Figure D-5, Appendix D)

Go on to Sheet 2

FINAL DRIVE REPAIR (Sheet 2 of 30)

SUPPLIES: Assorted sized blocks (wood)
Metal block
Crocus cloth (Item 3, Appendix B)
Dry cleaning solvent (Item 12, Appendix B)
Sealing compound (Item 7, Appendix B)
Sealing compound (Item 8, Appendix B)
Sealing compound (Item 9, Appendix B)
Nut
Gasket
Spacer
Bearing
Adhesive (Item 37, Appendix B)
Penetrating dye (Item 13, Appendix B)
Screw (5/8 x 18 x 4 inch) (4 required)
Lockwire (Item 26, Appendix B)
Oil (Item 17, Appendix B)
Gasket
Seal
Gasket
Seal assembly
Rags (Item 35, Appendix B)
Primer (Item 21, Appendix B)
Preformed packing
Preformed packing
Gloves (Item 31, Appendix B)
Goggles (Item 32, Appendix B)
Grease (Item 38, Appendix B)
Tape (Item 24, Appendix B)
Pipe (3-1/8 in. dia.)

PERSONNEL: Two

REFERENCES: TM 9-214
LO 5-5420-226-12
TM 5-5420-226-20

PRELIMINARY PROCEDURE: Remove final drive (TM 5-5420-226-20)

Go on the Sheet 3

FINAL DRIVE REPAIR (Sheet 3 of 30)

NOTE

There are two different types of final drives. Early model has three holes in end of shaft and late model shaft has five holes. Before performing this procedure, identify which final drive you have (early or late). Where the final drive repair differs, it will be noted.

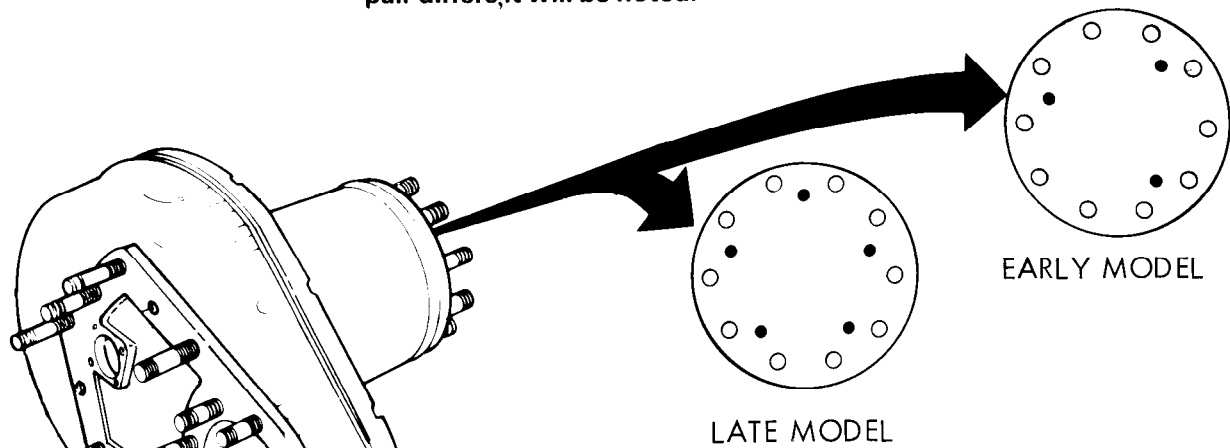

DISASSEMBLY:

1. Using lifting device, position final drive over drain pan.
2. Using hinged bar with 1/2 inch drive or 5/8 inch socket head screw key (allen wrench), remove four pipe plugs (A).
3. Allow oil to drain completely. When drained, place final drive assembly on working area.
4. Using 7/16 inch wrench, remove pressure relief valve (B) or vent elbow (B).
5. Using 3/16 inch allen wrench, remove plug (C).
6. Inspect 17 studs (D) for wear or damage. Replace as necessary.

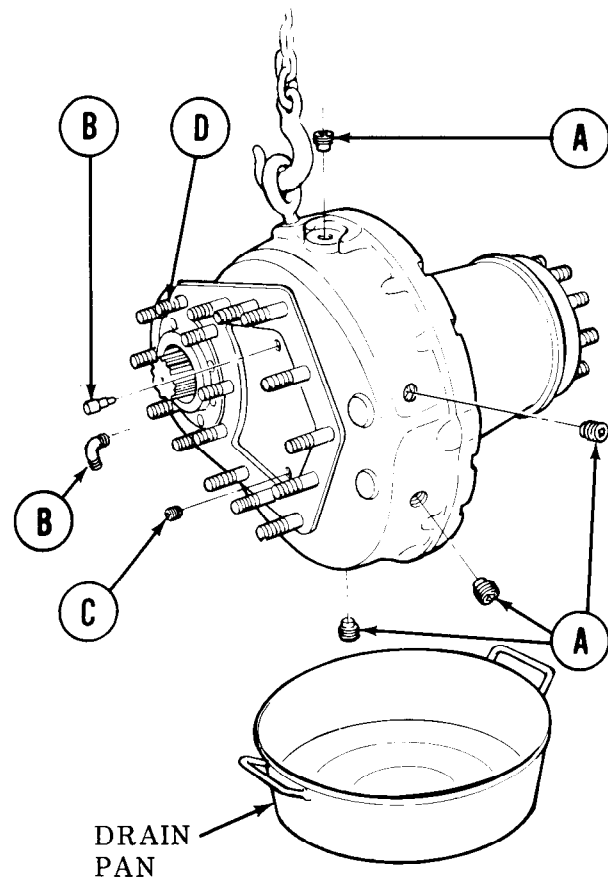

Go on to Sheet 4

FINAL DRIVE REPAIR (Sheet 4 of 30)

NOTE

Late model final drive has different type adapter (E).

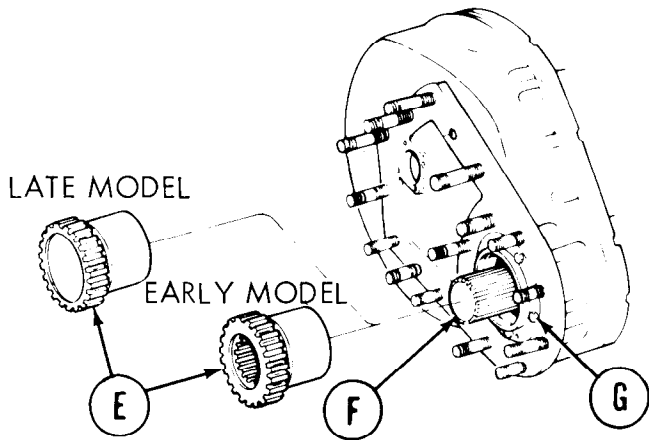

7. Using fingers, remove adapter (E) from pinion gear (F).
8. Using pliers, cut and remove lockwire from eight screws (G).
9. Using 3/4 inch socket, hinged bar, and extension with 1/2 inch drive, remove eight screws (G).

10. Using fingers, install three screws (use screws (G)) in bearing cap (H) holes (use screws (G) as jackscrews).

11. Using 3/4 inch socket, tighten three screws (G) evenly to remove bearing cap (H) and gasket (J).

12. Using 3/4 inch socket, remove three screws (G) from bearing cap (H).

13. Throw gasket (J) away.

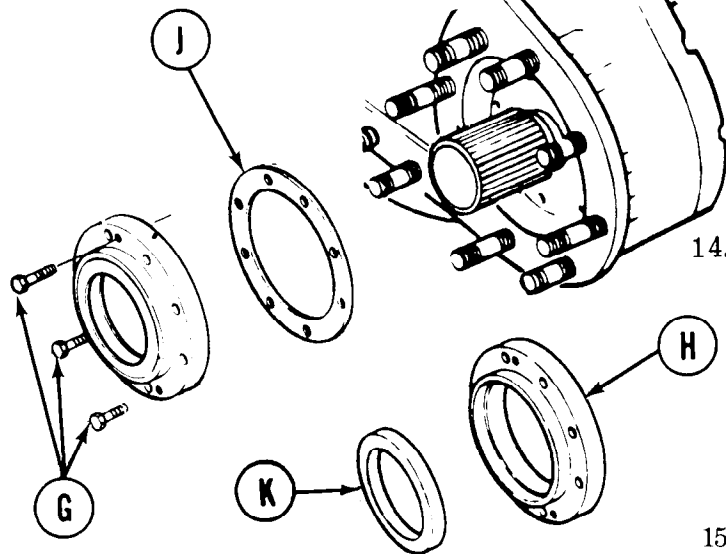
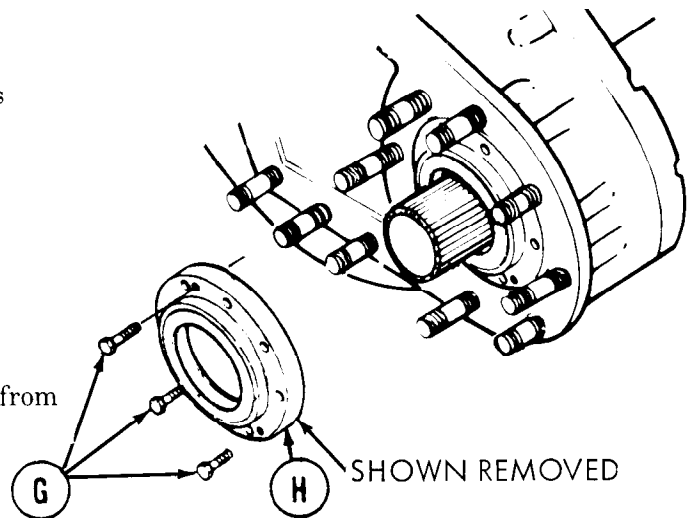

14. Using hammer and drift, remove oil seal (K) from bearing cap (H). Throw seal (K) away.

NOTE

For ease of handling, install fabricated lifting attachments on studs as required.

15. Use suitable lifting device, position final drive to gain access to opposite side.

Go on to Sheet 5

FINAL DRIVE REPAIR (Sheet 5 of 30)

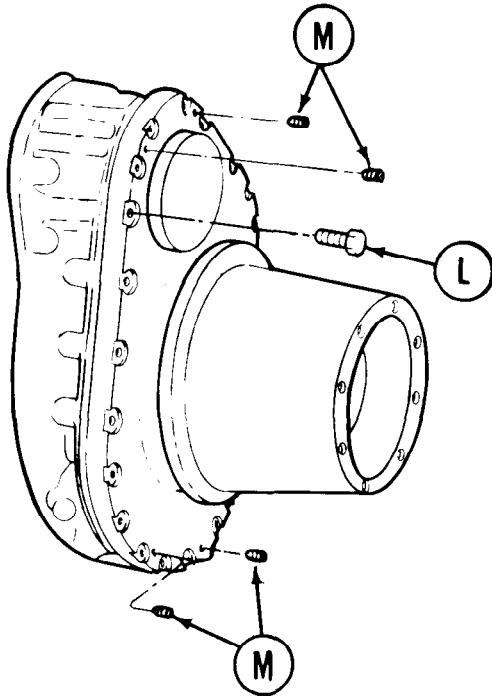

NOTE

- Early model final drives have 7/8 inch head bolts and late models have 1 inch head bolts.
- It may be necessary to use a handle extension on hinged handle to remove bolts (L).

- Using a 7/8 inch or 1 inch socket and hinged bar with 1/2 inch drive, remove twenty bolts (L).
- Using 5/16 inch allen wrench, remove four setscrews (M).

CAUTION

- Make sure setscrew holes have been tapped prior to installing jackscrews to avoid stripping.

- Keep surfaces of case and carrier parallel to avoid binding during separation.

- Using fingers, install four 5/8 x 18 x 4 inch jackscrews (N) in setscrew holes.
- Using 5/8 inch socket, slowly and evenly tighten the four jackscrews (N) to separate final drive carrier (P) from case (Q).
- Using 5/8 inch socket, remove four jackscrews (N) from final drive carrier (P).
- Using fingers, remove gasket (R). Throw gasket away.
- Using suitable lifting device, position final drive on its side.

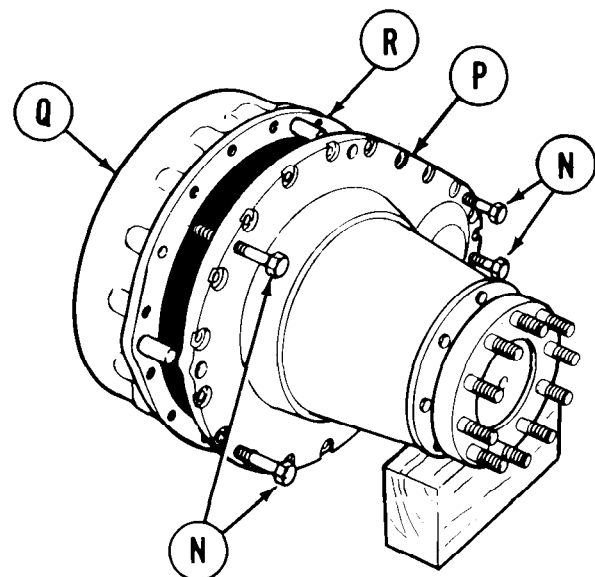

Go on to Sheet 6

FINAL DRIVE REPAIR (Sheet 6 of 30)

CAUTION

Protect threads of studs (S) with several layers of tape.

- 23. Place crowbar between output shaft studs (S) to prevent shaft from turning and stabilize carrier during nut removal.

NOTE

Late model nut does not have a lockwasher.

- 24. If required, use hammer and chisel to bend tangs of lockwasher away from nut (T).
- 25. Place special box wrench onto nut (T).

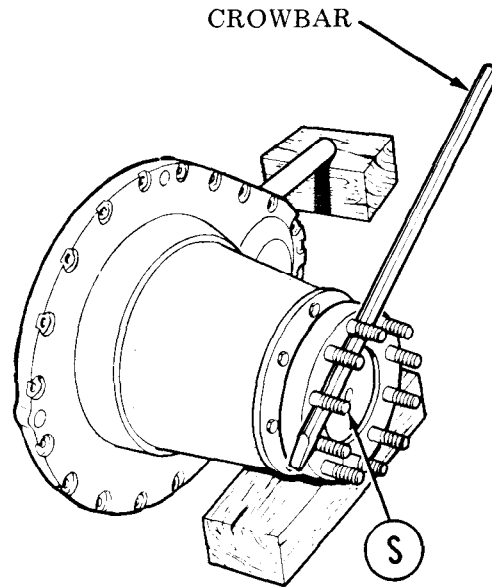

CAUTION

Support end of reactor bar against fixtured object (wood block). DO NOT rest against pinion gear (F).

- 26. Using PD 1201 torque wrench with 3/4-inch drive and reactor bar, loosen nut (T).
- 27. Remove nut (T) and lockwasher if present. Throw nut and lockwasher away.

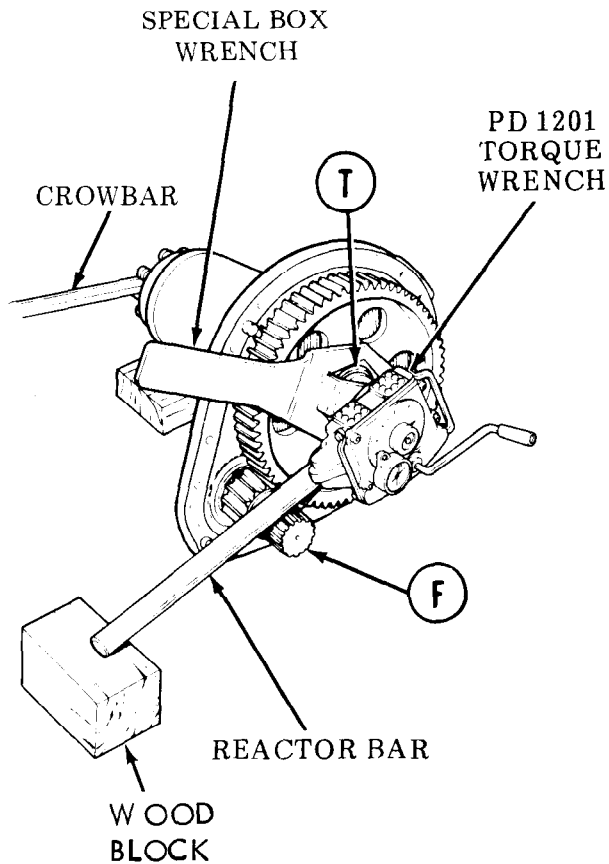

Go on to Sheet 7

FINAL DRIVE REPAIR (Sheet 7 of 30)

NOTE

Drive gear (U) and pinion gear (F) are a matched set and if replaced must be replaced as a set.

28. Remove crowbar from between output shaft studs (S).
29. Using two people, position final drive carrier (P) on floor with studs down and drive gear (U) up. Support carrier (P) with wooden blocks. Using two pry bars placed directly across from each other, carefully pry drive gear (U) upward, while pushing inward on pinion gear (F) with hand. Remove pinion gear (F) and drive gear (U).

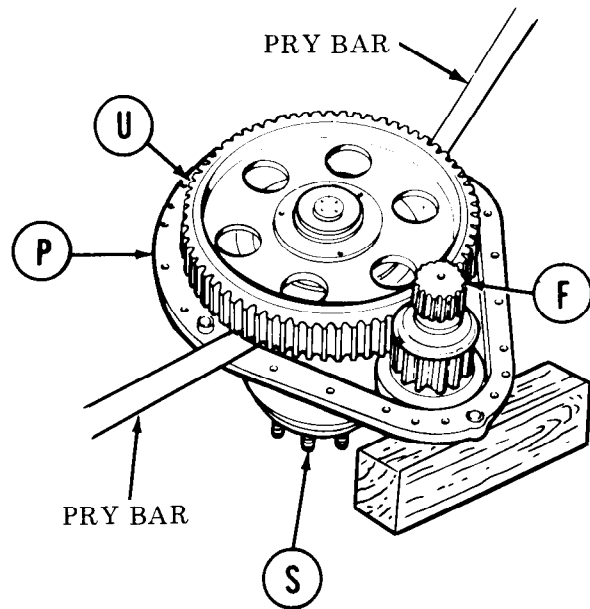

CAUTION

Care must be taken not to damage carrier assembly during gear removal.

NOTE

Two types of pinion bearings may be found during disassembly.

30. On final drive with late model pinion gear, remove bearing (V) from carrier (P).
31. On early model pinion gear, remove bearing outer race (W) from carrier (P). Old style bearing must be replaced.

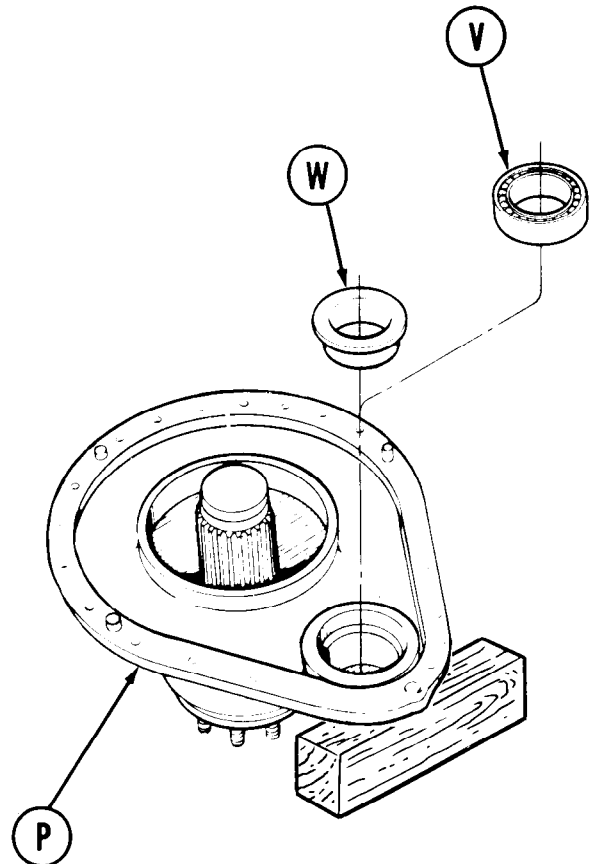

Go on to Sheet 8

FINAL DRIVE REPAIR (Sheet 8 of 30)

32. Using hammer and brass drift or wood block, remove bearing race (X) (early model) or bearing (Y) (late model) from case (Q).

CAUTION

Early model bearing and race must be replaced as part of up-grade.

NOTE

Do not replace any parts until after bearing pocket/bore checks are made.

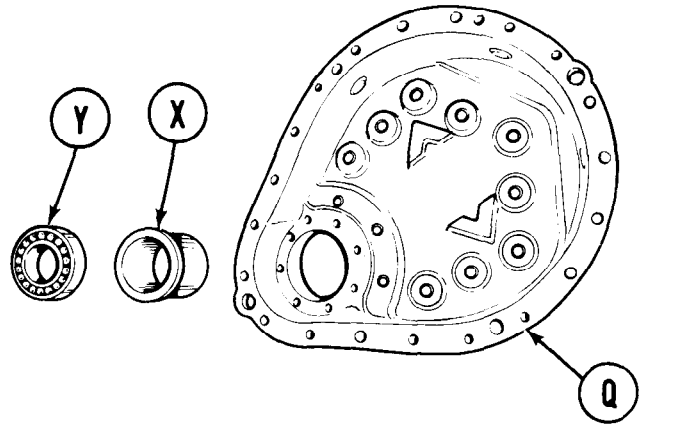

33. Make sure carrier (P) gasket surface (Z) and bearing shelf (AA) are clean prior to positioning parallel straight bar.
34. Position parallel straight bar on gasket surface (Z) across bearing pocket of carrier (P).
35. Using micrometer depth gage, measure from top of parallel bar to bearing shelf (AA) of carrier (P) and record reading.
36. Repeat measurement a minimum of four times in four equally spaced points. Record measurements.
37. Measure thickness of parallel bar and subtract from recorded measurements. If all measurements are between 1.347 and 1.357 inches (34.2138 and 34.4678 mm), go to step 39.

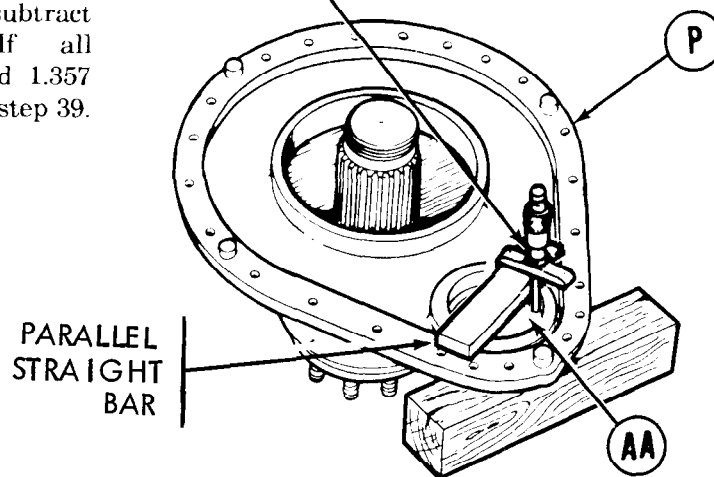
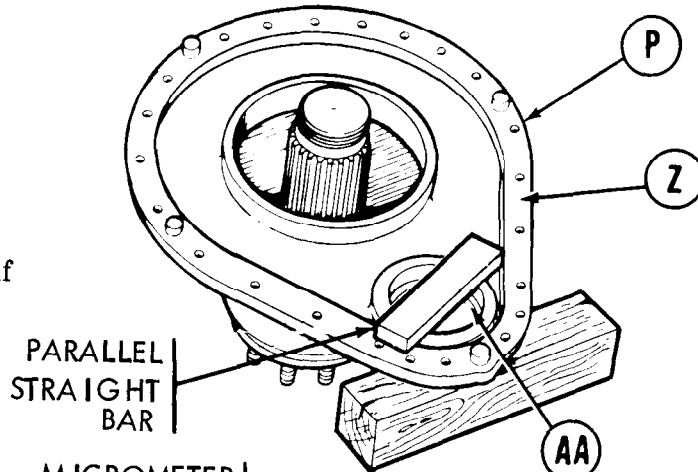

Go on to Sheet 9

FINAL DRIVE REPAIR (Sheet 9 of 30)

38. If any measurement is not within tolerance, reassemble final drive and tag "UNSERVICABLE (CARRIER POCKET DEPTH)." Return final drive to supply for depot rework.
39. Using inside micrometer, measure carrier bearing bore (AB) diameter a minimum of four times in four equally spaced points. Record readings.
40. If all measurements are between 5.5112 and 5.5130 inches (139.9845 and 140.0302 mm), go to step 42.
41. If any measurement is not within tolerance, reassemble final drive and tag "UNSERVICABLE (CARRIER BEARING BORE)." Return final drive to supply for depot rework.

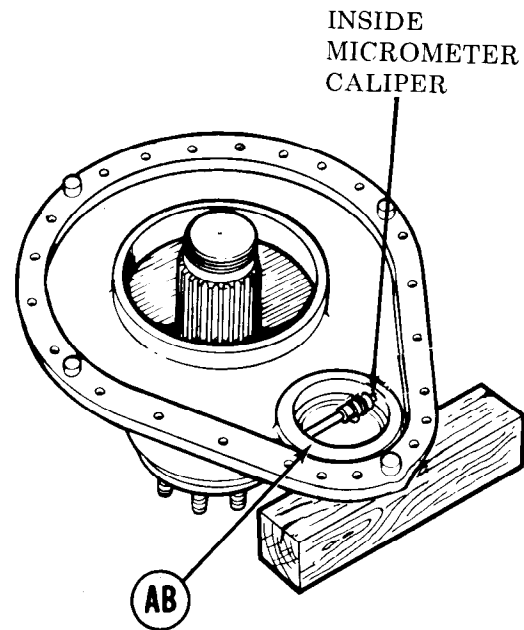

NOTE

Ensure case (Q) bearing cap surface (AC) and gasket surface (AD) are clean.

42. Position case (Q) on wood blocks with gasket surface (AD) down.
43. Hold parallel straight bar in place across gasket surface (AD) below bearing bore (AE).

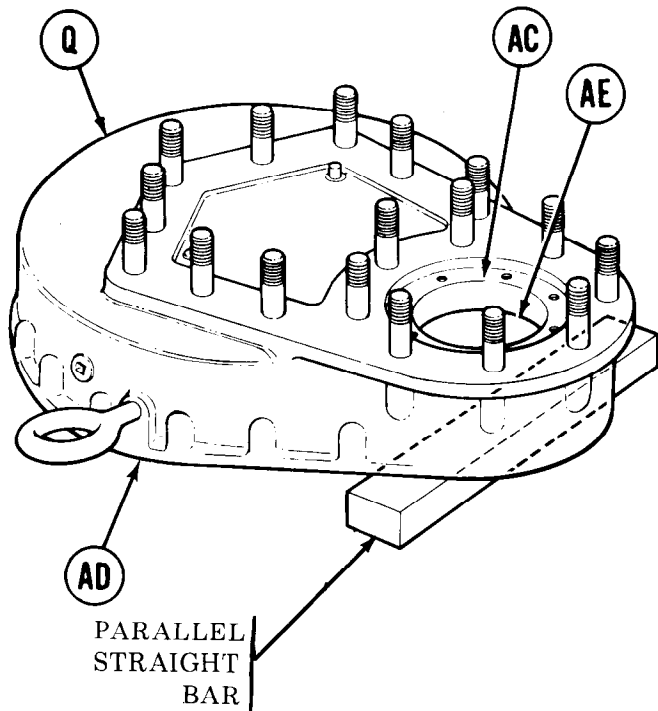

Go on to Sheet 10

FINAL DRIVE REPAIR (Sheet 10 of 30)

44. Using micrometer depth gage, measure from top of case bearing cap surface (AC) to top of parallel straight bar a minimum of four times at four equally spaced points. Record measurements.
45. If all measurements are between 4.479 and 4.489 inches (113.7666 and 114.0206 mm), go to step 47.
46. If any measurement is not within tolerance, reassemble final drive and tag "UNSERVICEABLE (CASE BEARING BORE DEPTH)." Return final drive to supply for depot rework.

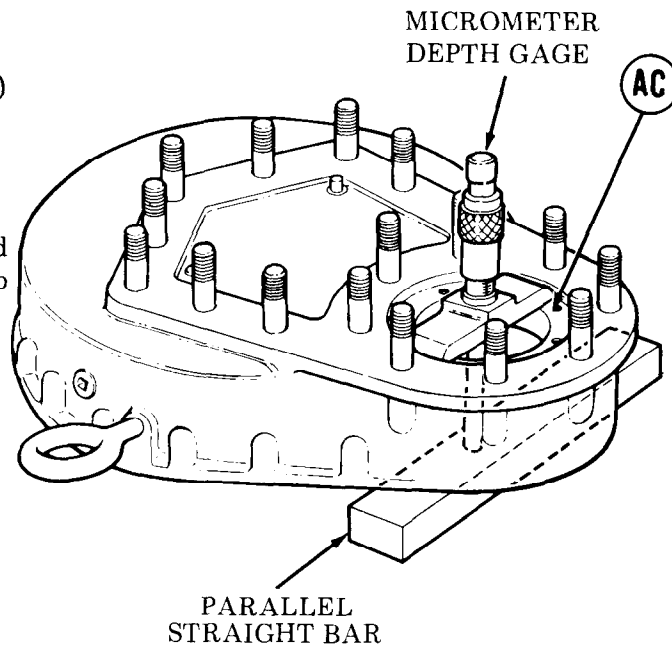

NOTE

Ensure case bearing bore surface (AE) is clean.

47. Using inside micrometer caliper, measure bearing bore (AE) diameter a minimum of four times at four equally spaced points. Record measurements.
48. If all measurements are between 5.5112 and 5.5130 inches (139.9845 and 140.0302 mm), go to step 42.
49. If any measurement is not within tolerance, reassemble final drive and tag "UNSERVICEABLE (CASE BEARING BORE DIAMETER)." Return final drive to supply for depot rework.

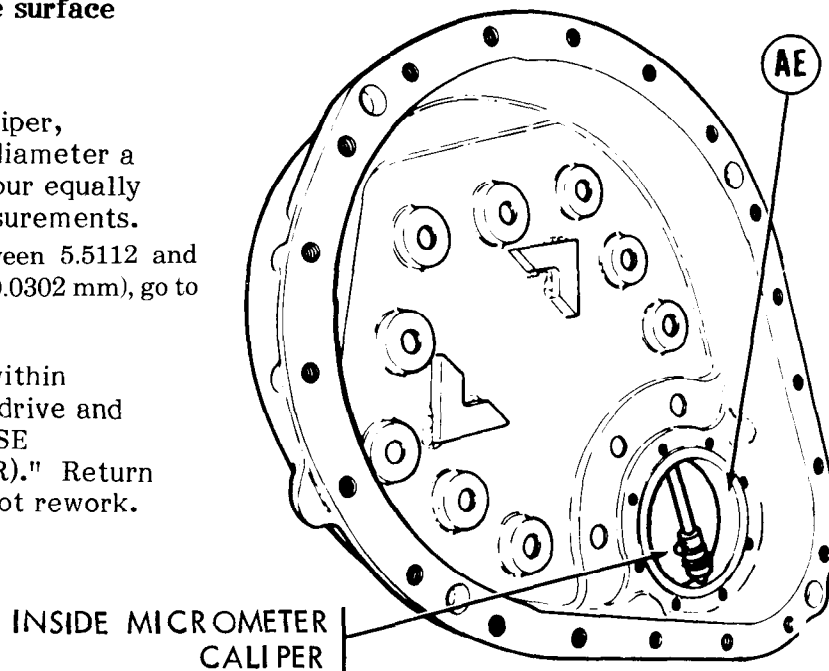

Go on to Sheet 11

FINAL DRIVE REPAIR (Sheet 11 of 30)

- 50. Using bearing puller or hammer and drift, remove bearings (AF - early model) or bearing inner races (AG - late model) from pinion (F). Throw away pinion bearings and races.
- 51. Pinion bearings (AF or AG) must be replaced as part of overhaul.

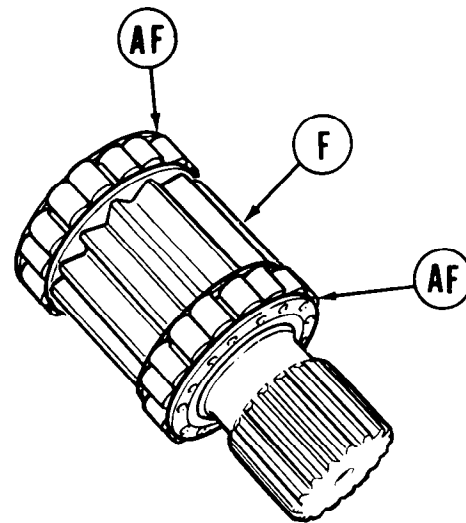

EARLY MODEL

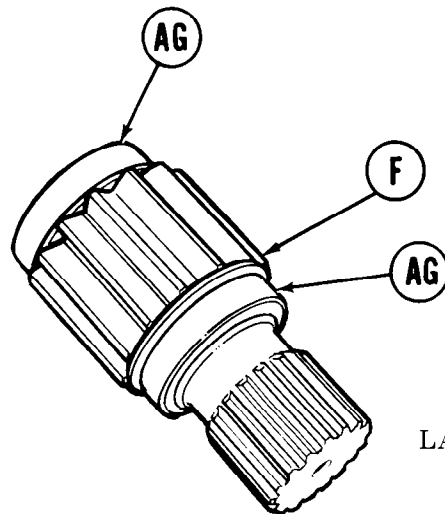

LATE MODEL

- 52. Remove spacer (AH) from output shaft (AJ).
- 53. Inspect spacer (AH) for damage or pitting.
- 54. If unserviceable, discard, or fabricate special tool.

NOTE

Spacer (AH) may be used to fabricate the special tool required to seat output shaft and drive gear bearings (Figure 4, Appendix D).

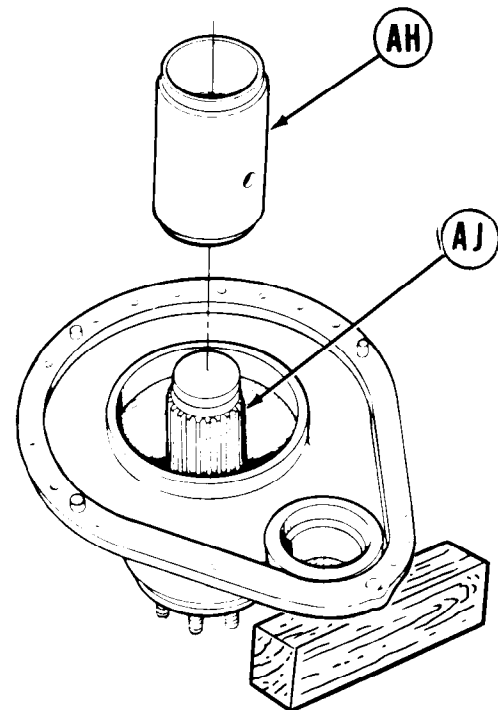

Go on to Sheet 12

FINAL DRIVE REPAIR (Sheet 12 of 30)

55. Using suitable lifting device, position final drive carrier (P) on two wood blocks.
56. Using diagonal cutting pliers, cut and remove lockwire (AK) from eight bolts (AL).
57. Using 3/4-inch wrench, loosen bolts (AL) until heads of bolts touch output shaft flange (AM).
58. Using suitable lifting device, carefully lift output shaft (AJ) while continuing to loosen bolts (AL).
59. Lift output shaft (AJ) free of carrier (P).

NOTE

To free output shaft (AJ) from carrier (P), it may be necessary to tap side of carrier (P) while lifting output shaft (AJ).

60. Remove and throw away gasket (AN).

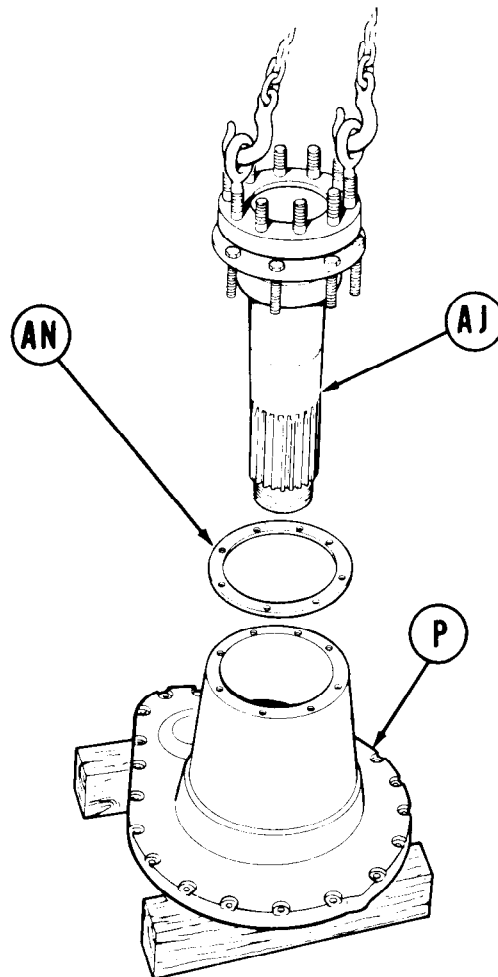
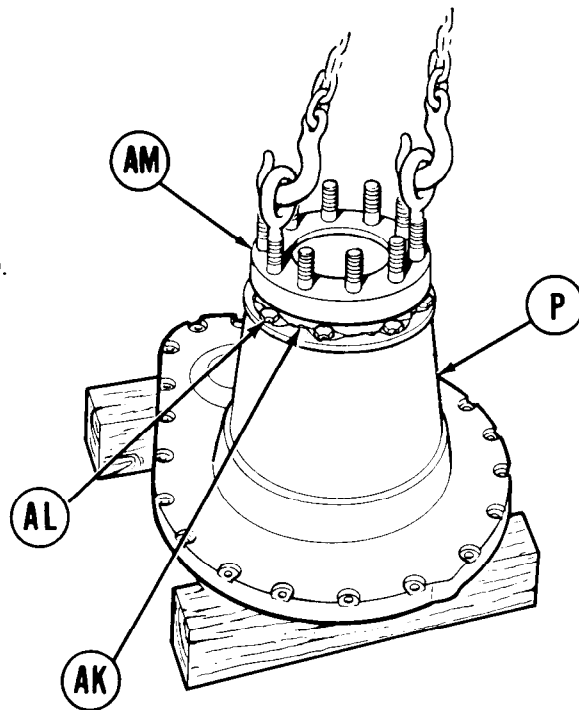

Go on to Sheet 13

FINAL DRIVE REPAIR (Sheet 13 of 30)

NOTE

Before completing disassembly, perform cleaning and inspection of case, carrier, and gears.

61. Clean gasket surfaces, as necessary, using putty knife or gasket scraper.

WARNING

Dry cleaning solvent P-D-680 is toxic and flammable. To avoid injury, wear protective goggles and gloves and use in a well-ventilated area. Avoid contact with skin, eyes, and clothes, and do not breathe vapors. Do not use near open fire or excessive heat. The flash point for Type I dry cleaning solvent is 100°F (38°C) and for Type II is 140°F (60°C). If you become dizzy while using dry cleaning solvent, get fresh air immediately and get medical aid. If contact with eyes is made, wash your eyes with water and get medical aid immediately.

62. Clean all parts using dry cleaning solvent and clean rags.

NOTE

Case and carrier are a matched set. If either part is unserviceable, reassemble final drive, using old parts, tag unserviceable, and return through supply channels for depot overhaul. Case and carrier must be thoroughly cleaned before inspection.

63. Using penetrating dye, inspect carrier (P) and case (Q) for cracks or fractures.
64. Using crocus cloth, remove minor scores and burrs from machined surfaces.

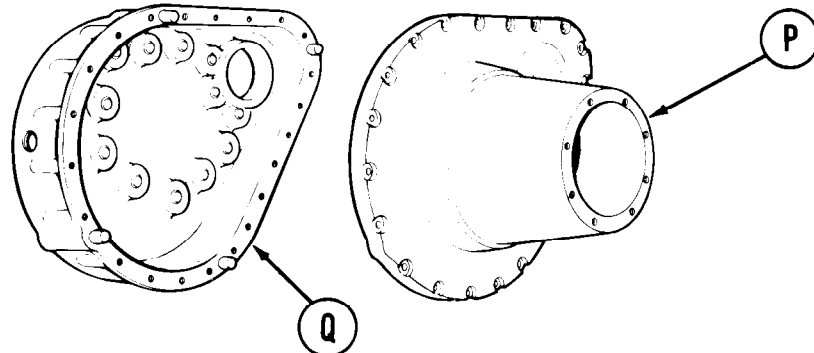

Go on to Sheet 14

FINAL DRIVE REPAIR (Sheet 14 of 30)

65. Using inside micrometer, measure case (Q) bore diameters (AP and AQ) a minimum of four times at four equally spaced points. Record measurements.
66. If measurements do not exceed 9.0578 inches (230.0681 mm) at (AP) and 9.8452 inches (250.0681 mm) at (AQ), go to step 68.
67. If any measurement exceeds the above, reassemble final drive and tag "UNSERVICEABLE (CARRIER BEARING BORE)." Return final drive to supply for depot rework.

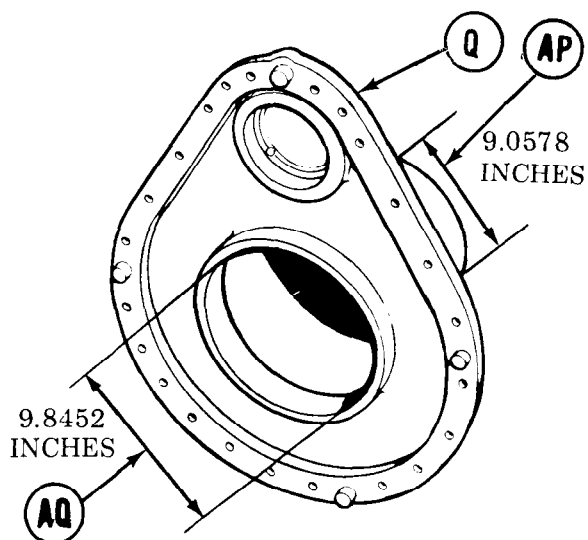

NOTE

Drive gear (U) and pinion gear (F) are a matched set. If either gear is unserviceable, both gears must be replaced as a set.

68. Check drive gear (U) and pinion gear (F) for cracked, broken, or chipped teeth. Replace set if either gear is unserviceable.
69. Using penetrating dye, check drive gear (U) and pinion gear (F) for pitting.

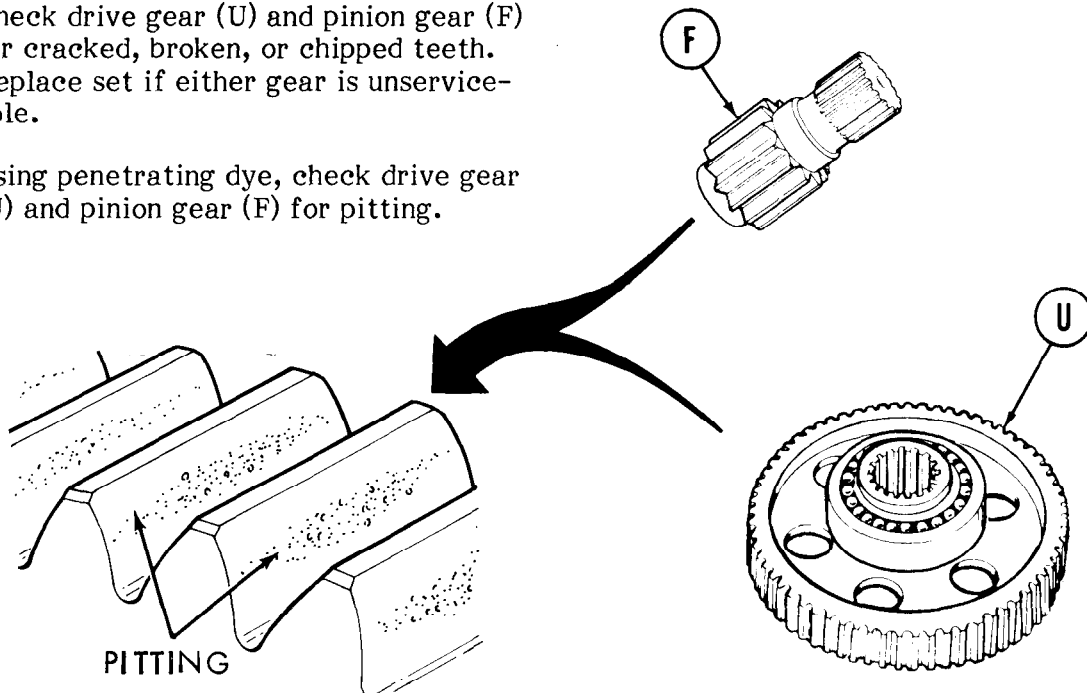

Go on to Sheet 15

FINAL DRIVE REPAIR (Sheet 15 of 30)

- 70. Using outside micrometer caliper, measure pinion gear (F) race surface diameters (AR) each a minimum of four times at four different points. Record measurements.
- 71. If all measurements are between 3.1511 and 3.1504 inches (80.0379 and 80.0202 mm), go to step 78.
- 72. If all measurements are not within tolerance, replace gear set and go to step 73.

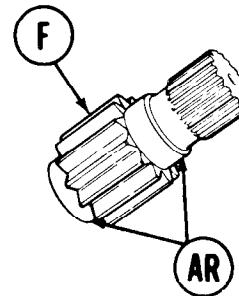

- 73. Install three short (3-1/2 inches) pins and washers in bearing remover tool holes marked "C."

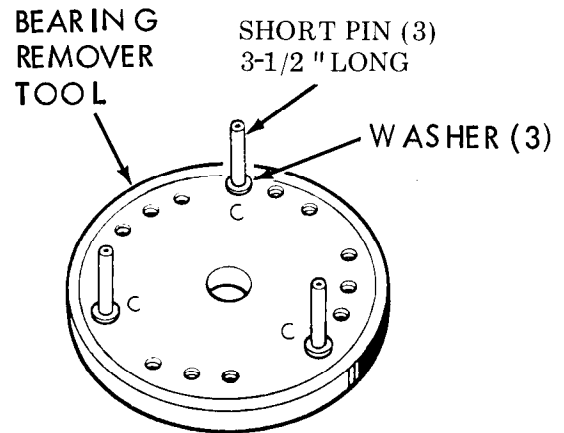

- 74. Using two persons, support drive gear (U) on blocks (4 inches high) on arbor press.
- 75. Position bearing remover tool on drive gear (U) with pins on drive gear bearing (AS).
- 76. Using arbor press, apply pressure to center of bearing remover tool and push bearing (AS) from drive gear (U).
- 77. Remove bearing remover tool from drive gear (U).

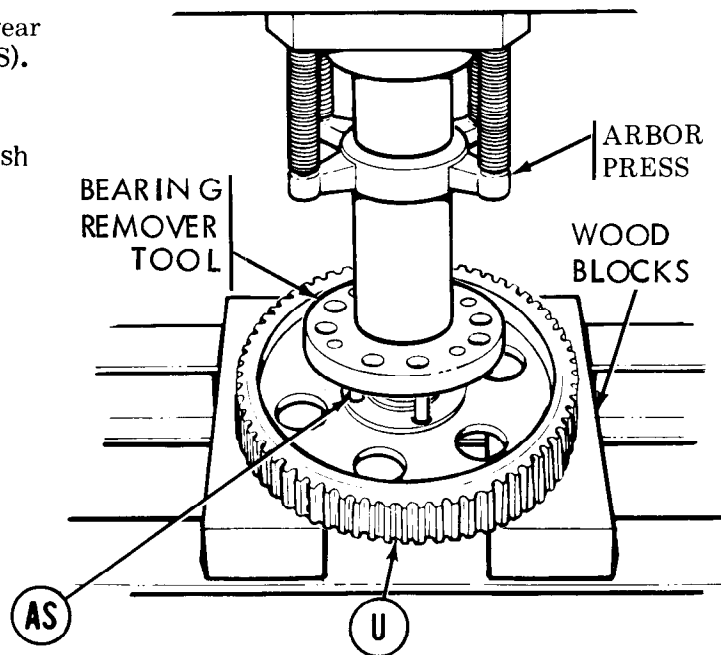

Go on to Sheet 16

FINAL DRIVE REPAIR (Sheet 16 of 30)

- 78. Install three short pins (3-1/2 inches long) and washers into holes marked "B" in bearing remover tool.
- 79. Check that three pins match holes in output shaft (AJ).

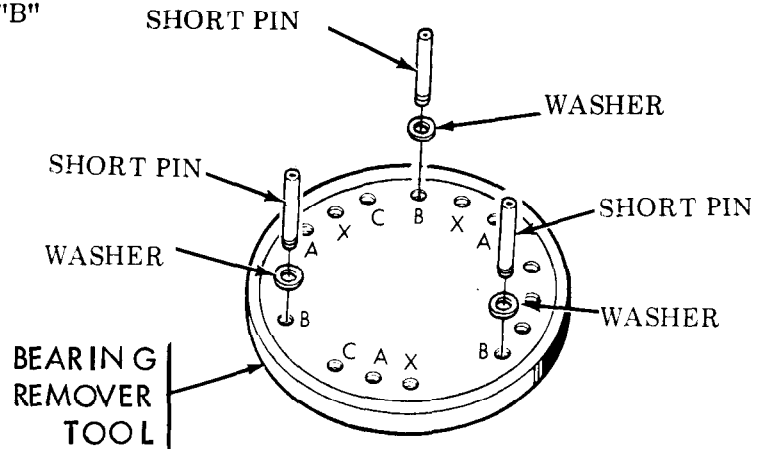

- 80. Position bearing remover tool above output shaft (AJ) assembly with pins through matching holes in flange (AM) of output shaft (AJ) assembly.
- 81. Using two people, support output shaft (AJ) and position bearing remover tool and output shaft (AJ) under arbor press.
- 82. Using arbor press, apply pressure to center of bearing remover tool until remover touches face of output shaft(AJ).
- 83. Release arbor press pressure and remove bearing remover tool from output shaft (AJ).
- 84. Remove short pins from bearing remover tool and replace with 5 inch pins.

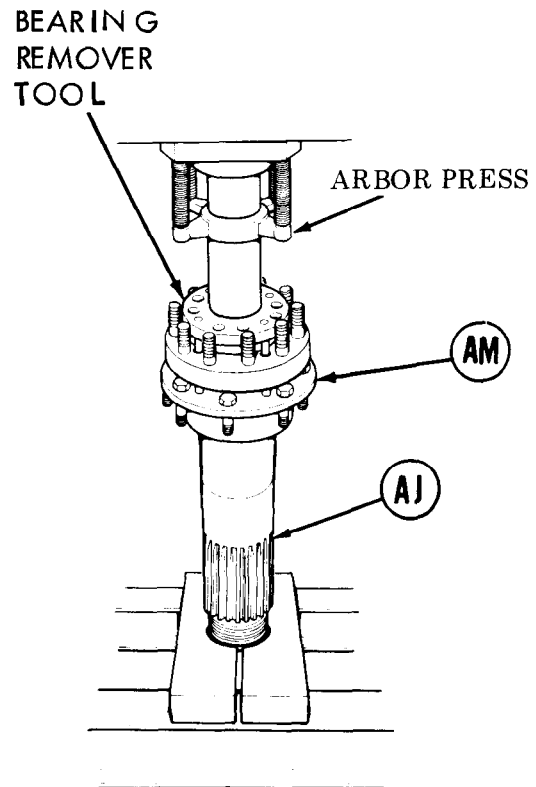

Go on to Sheet 17

FINAL DRIVE REPAIR (Sheet 17 of 30)

WARNING

Keep hands clear of bearing (AT) during pressing operation. Bearing will fall free of shaft and injury could result.

85. Repeat steps 82 and 83 until bearing (AT) is forced from shoulder of output shaft (AJ).
86. Release arbor press pressure and remove bearing remover tool and output shaft (AJ) from press.
87. Remove bearing remover tool from output shaft (AJ).
88. Remove bearing (AT) and cap assembly (AU) from output shaft (AJ). Dispose of old style output shaft in accordance with AR755-1.
89. Remove ring (AV) with eight bolts (AL). Remove bolts (AL) from ring (AV). Retain ring (AV).
90. Remove seal (AW), spacer (AX), and seal (AY) from cap (AZ). Retain cap (AZ). Throw away seal (AW), seal (AY), and spacer (AX).

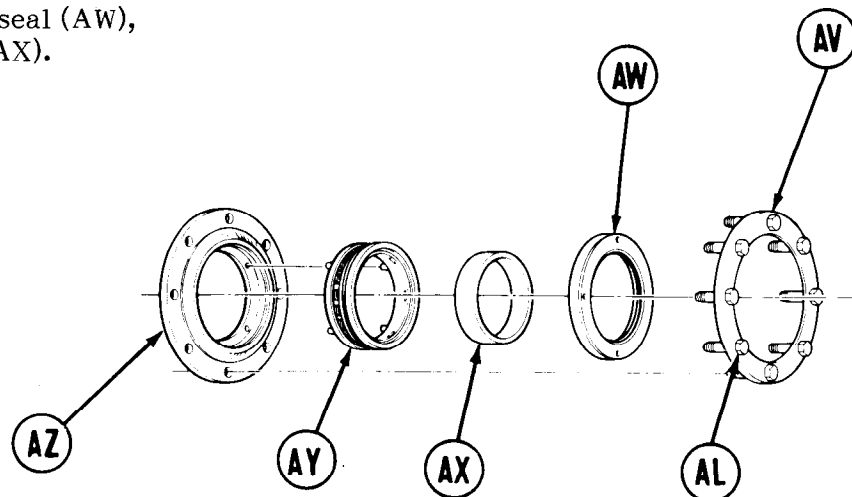
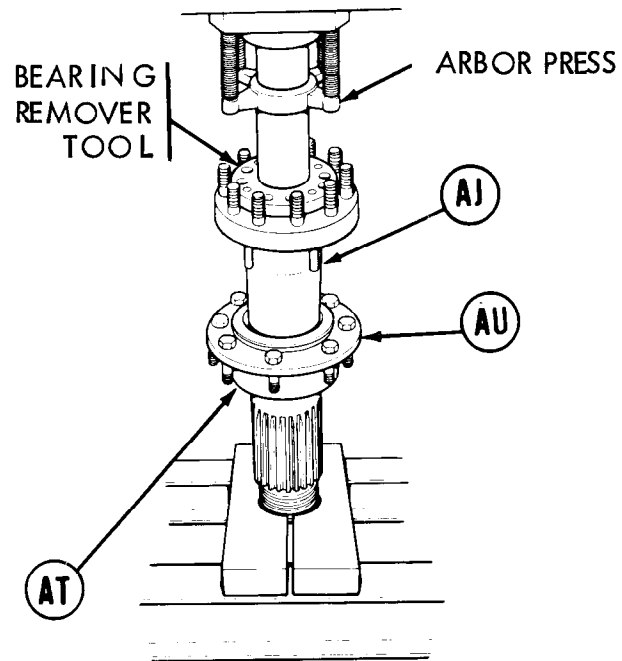

Go on to Sheet 18

FINAL DRIVE REPAIR (Sheet 18 of 30)

91. Inspect output shaft bearing (AT) and drive gear bearing (AS) for serviceability in accordance with TM 9-214. Replace bearings as necessary. If bearing (AS) must be replaced, refer to steps 73 thru 77 for removal of bearing from drive gear (U).

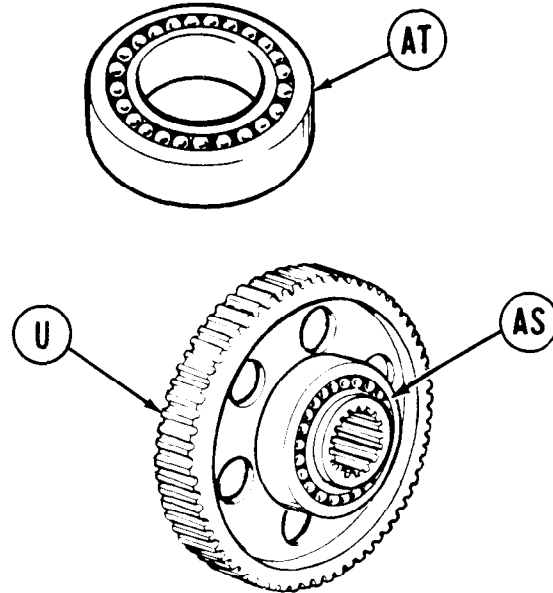

ASSEMBLY:

NOTE

When installing preformed packings or o-rings, ensure there are no burrs, nicks, or sharp edges which could cut or damage these parts during installation. Use oil (Item 16, Appendix B) to lubricate both packings (o-rings) and parts for ease of installation.

1. Apply adhesive to output shaft (A) in area indicated and to five output shaft holes, 1/8 inch below flange surface.

NOTE

Preformed packing (B) is part of late model spacers (C). If preformed packing (B) is installed on spacer (C), go to step 3.

2. Apply oil to preformed packing (B) and install on spacer (C).
3. Install spacer (C) on shaft (A), with wide portion toward shaft flange, and seat spacer (C) against flange.

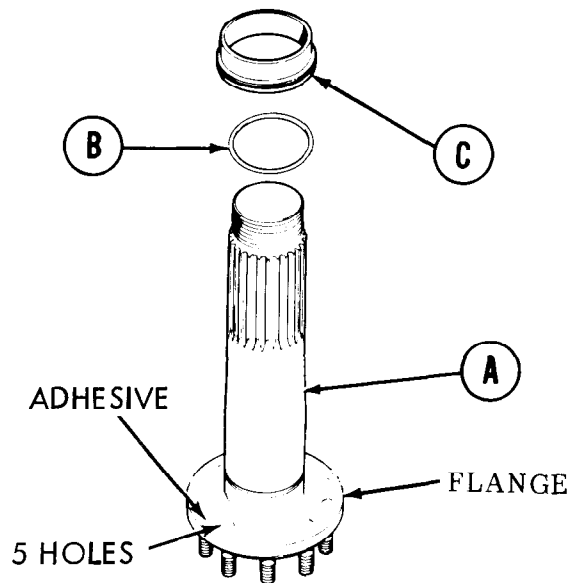

Go on to Sheet 19

FINAL DRIVE REPAIR (Sheet 19 of 30)

4. Apply oil to preformed packing (D) and install on special tool oil seal replacer (E).
5. Install oil seal replacer (E) over splined end of shaft (A) with preformed packing end down. Push replacer down to bearing surface of shaft.
6. Roll preformed packing (D) off replacer (E) and on shaft (A).
7. With replacer (E) in same position, carefully press preformed packing (D) into recessed area between spacer (C) and shaft (A). Seat preformed packing (D) flush or below top edge of spacer (C).
8. Remove replacer (E) from shaft (A).
9. Using clean, lint-free rag, wipe both inner and outer parts of seals (F) and (G) to remove any foreign material. Apply oil to surfaces of seals (F) and (G).
10. Apply oil to o-ring (H). Install o-ring (H) on spring seal (G).
11. Install spring seal (G) in cap (J) with four pins thru four holes in cap (J).
12. Place seal (F) over output shaft (A). Aline seal (F) hole with output shaft (A) pin and press down to engage spacer (C).
13. Install eight bolts (K) in ring (L).
14. Using two persons, lift ring (L) and position on output shaft (A).
15. With cap (J) seal side facing spacer (C), place cap (J) over spacer (C) with eight bolts (K) thru eight holes of cap (J).
16. Grasp cap (J) and press down firmly. Cap (J) will spring back when properly installed.

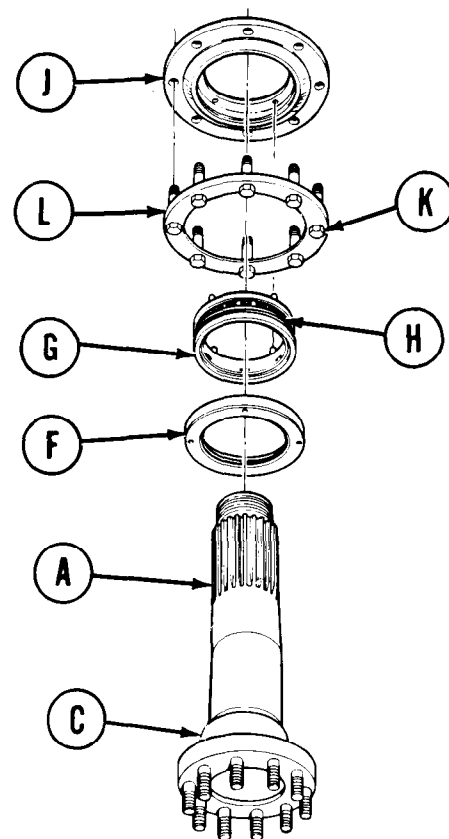
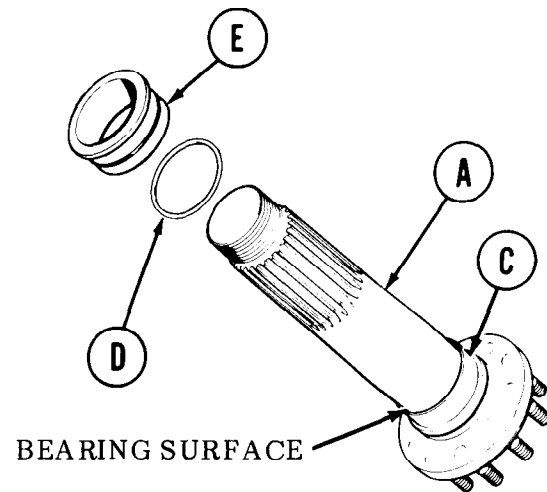

Go on to Sheet 20

FINAL DRIVE REPAIR (Sheet 20 of 30)

17. Apply light coat of grease to machined surface of output shaft (A).
18. Position bearing (M) on output shaft (A).
19. Using two persons, or lifting device, position output shaft (A) in arbor press.

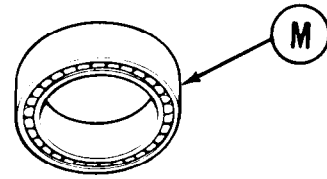

20. Place one output shaft bearing installer over output shaft (A) with small opening facing bearing (M). Bearing installer must engage bearing (M) inner race.

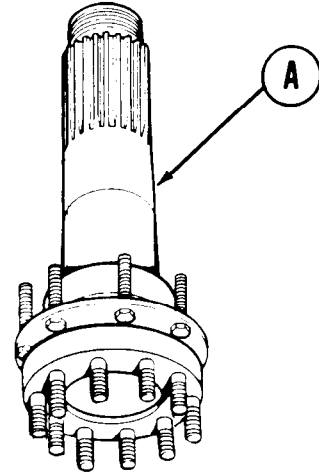

21. Place second output shaft bearing installer over output shaft (A) with large opening facing first bearing installer.

22. Place metal block on bearing installer.

23. Aline output shaft (A) under arbor press ram.

24. Apply arbor press pressure to seat bearing (M) on output shaft (A).

25. Release pressure. Remove metal block and two bearing installers.

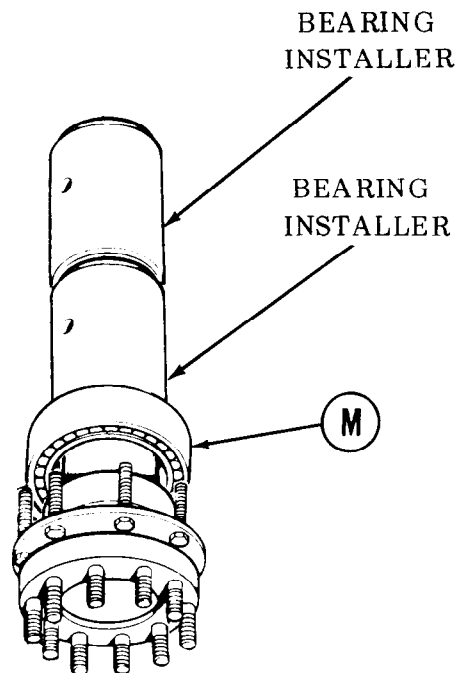

Go on to Sheet 21

FINAL DRIVE REPAIR (Sheet 21 of 30)

26. Position carrier (N) on wood blocks.
27. Place new gasket (P) on carrier (N).
Aline holes.
28. Using suitable lifting device, install assembled shaft (A) into carrier (N). It may be necessary to tap sides of carrier (N) to seat shaft (A). Make sure gasket (P) is on screws (Q) and screws (Q) line up with holes in carrier (N).
29. Using 3/4 inch wrench, tighten eight screws (Q). Using torque wrench with crowfoot, tighten screws to 90-130 lb-ft (122-176 N·m).
30. Install lockwire in pairs on screws (Q).
31. Using suitable lifting device, turn carrier (N) over and support with wood blocks for further assembly.
32. Install spacer (R) on output shaft (A) assembly, wide end toward output shaft flange.

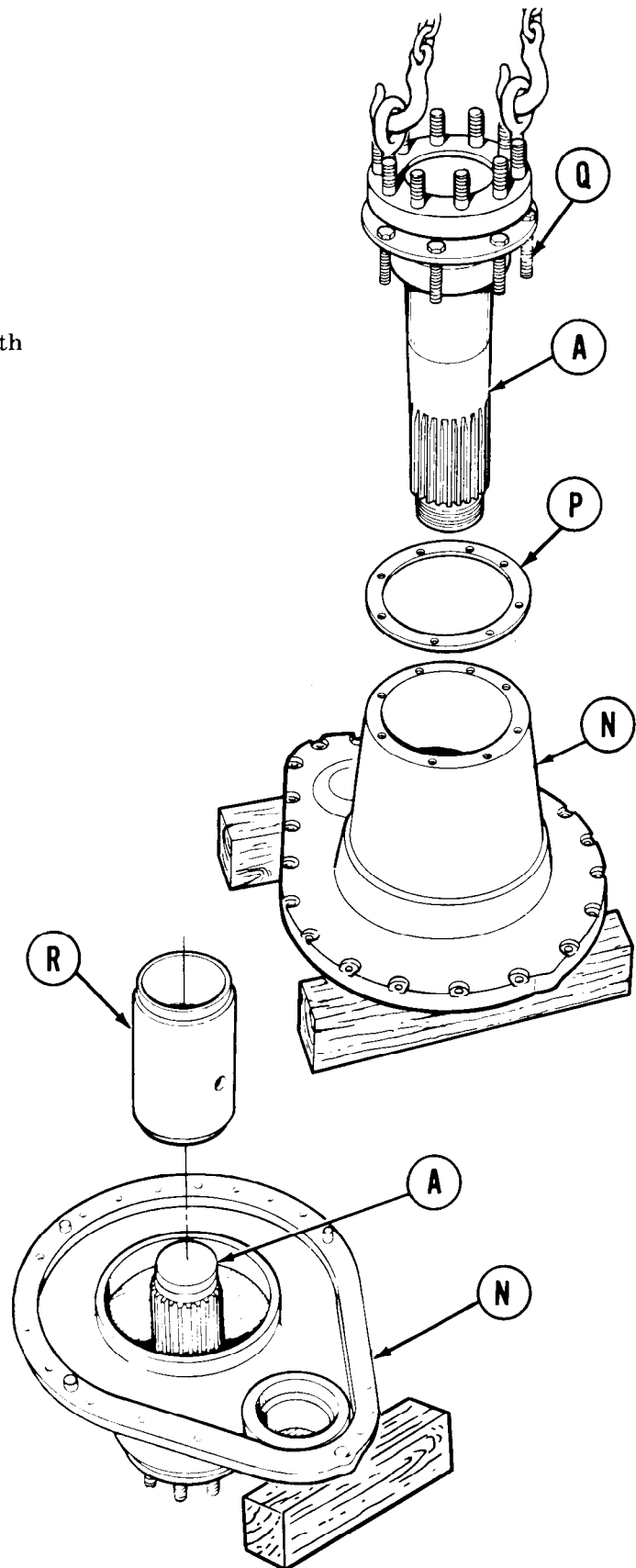

Go on to Sheet 22

FINAL DRIVE REPAIR (Sheet 22 of 30)

NOTE

Tag both parts of each bearing so that same parts can be paired up later. Keep both parts of each bearing together, except when heating or cooling.

33. Place two bearings (S) (outer races with rollers) on dry ice or in refrigerator freezer for 30 to 45 minutes.

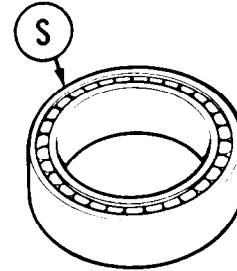

34. Ensure bearing bore (T) of case (U) and bearing pocket (V) of carrier (N) are clean, dry, and free of foreign material.

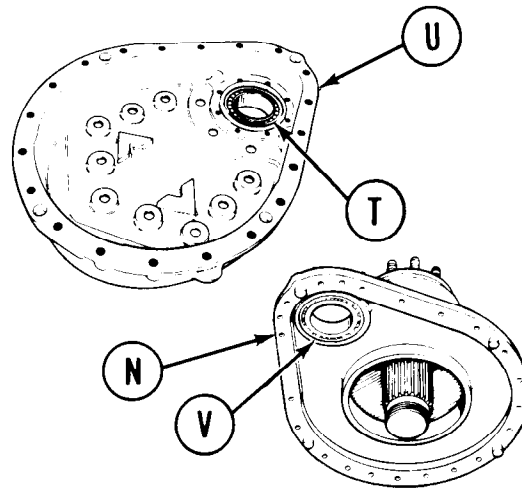

35. Position cap (W) in arbor press. Position seal (X) on cap (W) with rubber seal facing down. Using wood block and arbor press, press seal (X) into cap (W) until seal (X) is flush with cap (W).

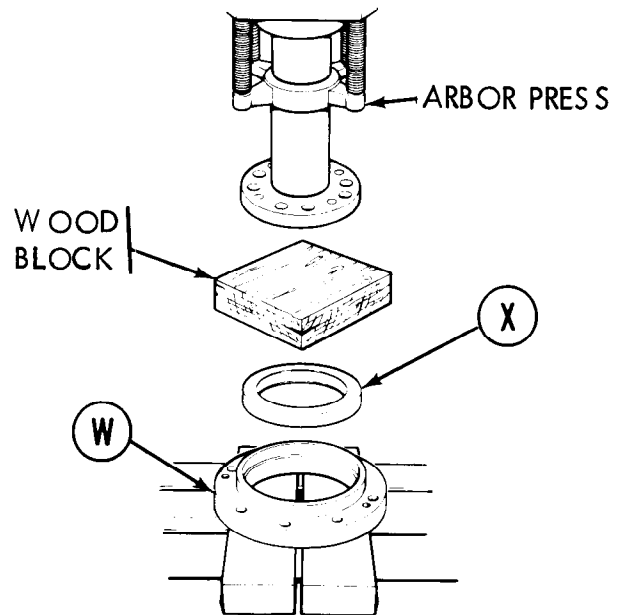

Go on to Sheet 23

FINAL DRIVE REPAIR (Sheet 23 of 30)

36. Position new gasket (Y) and assembled cap (W) and seal (X) on case (U).
37. Apply primer to all threaded holes in case (U).
38. Apply sealing compound (Item 7, Appendix B) to threads of eight screws (Z). Using 3/4 inch socket, install eight screws (Z) to secure cap (W).

WARNING

Wear gloves when handling frozen parts to prevent serious injury to your hands.

39. Remove one bearing (S) from refrigerant and quickly install in carrier (N) bearing pocket (V). Ensure bearing (S) is seated in bearing pocket (V).
40. Remove second bearing (S) from refrigerant and quickly install in case (U) bearing bore (T). Ensure bearing (S) is seated in bearing bore (T).
41. Using inspection mirror, ensure bearings (S) are fully seated in bearing pocket (V) and bearing bore (T). If bearings (S) are seated, go to step 43. If bearings (S) are not seated, go to step 42.
42. If bearing (S) is not seated in carrier (N), using bearing mechanical puller kit, remove bearing (S) from carrier (N). Repeat steps 33, 39, and 41. If bearing (S) is not seated in case (U), using universal mechanical puller, remove bearing (S) from case (U). Repeat steps 33, 40, and 41.

CAUTION

If staking of bearing (S) is required, do not hit bearing with punch or hammer. Damage to bearing (S) could result.

43. Check bearing (S) for looseness. If loose, using hammer and center punch, stake bearing (S) pocket in three places to hold bearing (S) in place during assembly.

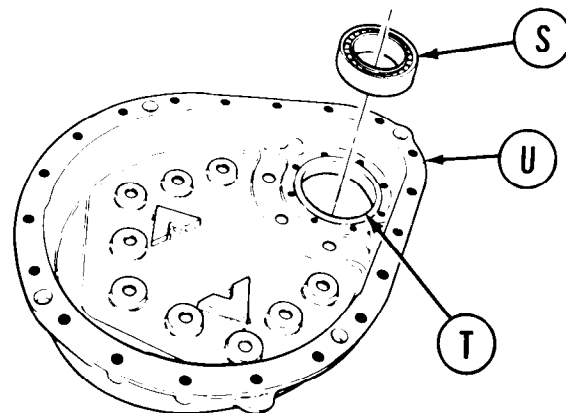
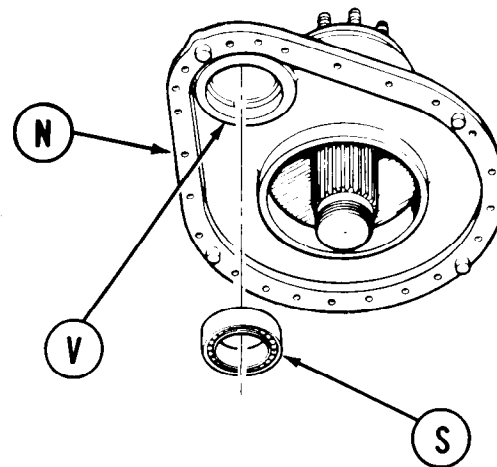
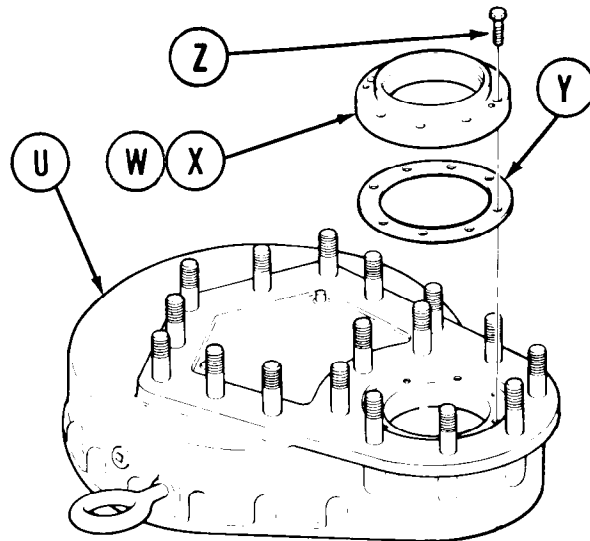

Go on to Sheet 24

FINAL DRIVE REPAIR (Sheet 24 of 30)

44. Install inner race (AA) on pinion gear (AB) with flange toward gear segments.
45. Place race (AA) and pinion gear (AB) in press with splined end up.
46. Apply pressure to splined end of pinion gear (AB) until race (AA) is seated on pinion gear. Release arbor press pressure.
47. Install second race (AC) on pinion gear (AB). Place 10 inch section of 3-1/8 inch I.D. pipe over splined end of pinion gear (AB) so pipe engages race (AC).
48. Using arbor press, apply pressure to pipe until race (AC) is fully seated on pinion bearing shoulder.

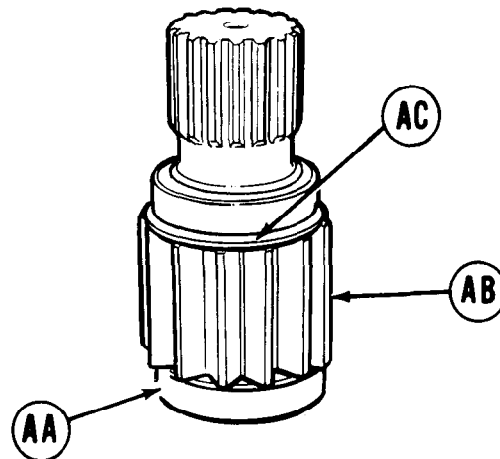

NOTE

If output bearing or gear set was replaced, go to step 49. If bearing or gear set was not replaced, the bearing is still on the drive gear; go to step 54.

49. Lightly grease drive gear (AD) mating surface.
50. Position drive gear (AD) in arbor press on supporting material.
51. Position bearing (AE) on drive gear (AD).
52. Position bearing installer over drive gear (AD) shaft on bearing (AE) inner race.

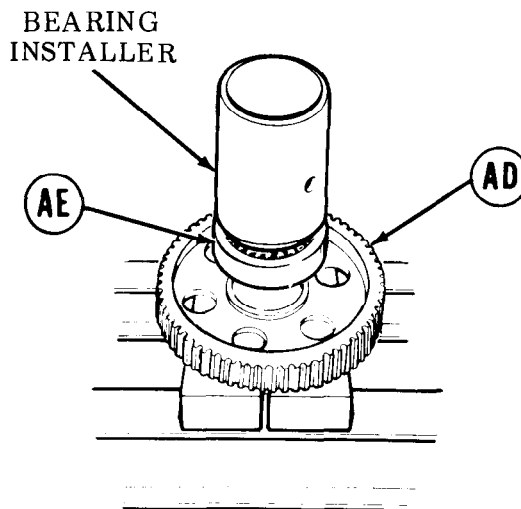
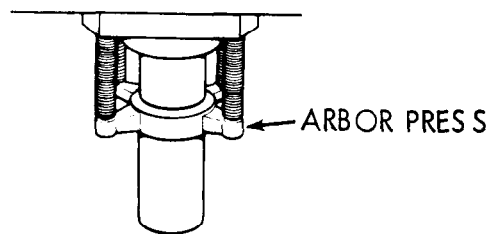

Go on to Sheet 25

FINAL DRIVE REPAIR (Sheet 25 of 30)

CAUTION

Place supports under center of drive gear (AD) to prevent damage during pressing operation.

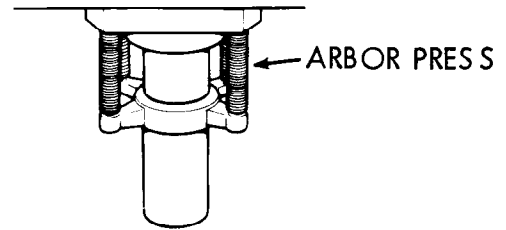

- 53. Position metal block on bearing installer. Using arbor press, apply pressure to plate until bearing (AE) is fully seated on drive gear (AD).
- 54. Position drive gear (AD) in carrier (N).

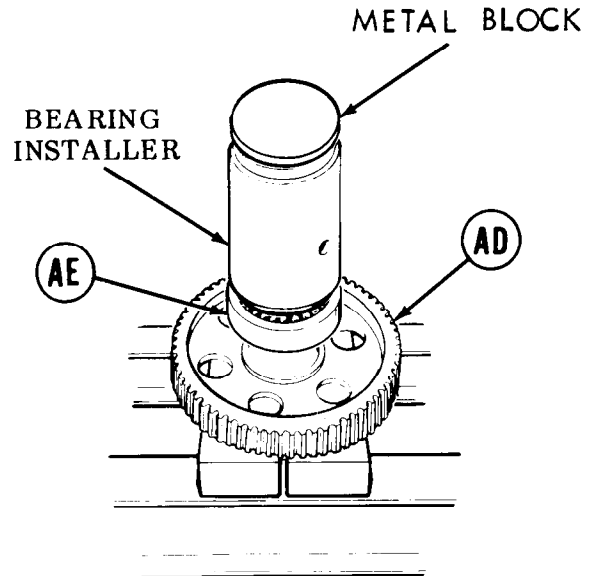

- 55. Using two pry bars positioned directly across from each other, carefully pry drive gear (AD) up and mesh drive gear (AD) with pinion gear (AB).
- 56. Carefully lower drive gear (AD) and pinion gear (AB) into carrier (N) until seated.
- 57. Apply oil to threads of output shaft (A) and nut (AF).
- 58. Install self-locking nut (AF) onto output shaft (A). Using special box wrench, tighten nut (AF).

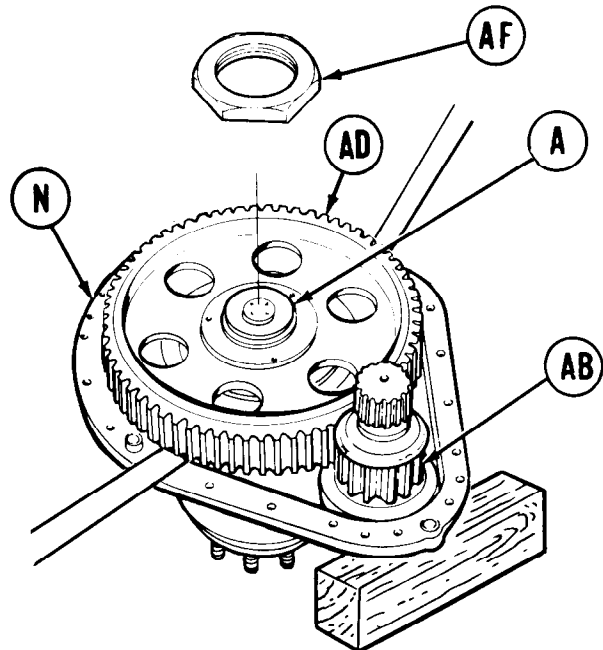

Go on to Sheet 26

FINAL DRIVE REPAIR (Sheet 26 of 30)

- 59. Using suitable lifting device, position final drive (AG) on wood block.
- 60. Using tape, cover threads on stud (AH) to prevent thread damage during assembly.
- 61. Position crowbar between studs (AH) to prevent output shaft (A) from turning and to stabilize final drive (AG).

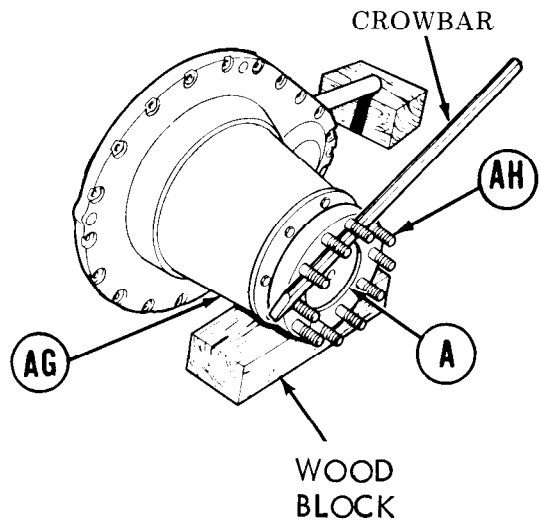

- 62. Position special box wrench on nut (AF). Attach PD 1201 torque wrench to box wrench.

CAUTION

Do not rest reactor bar against pinion gear (AB). Damage to gear will result.

- 63. With reactor bar supported against wood block, apply 1100-1500 lb-ft (1492-2034 N·m) torque to nut (AF).
- 64. Wait one minute. Apply torque again.
- 65. Continue to apply torque until reading stabilizes between 1100-1500 lb-ft (1492-2034 N·m).

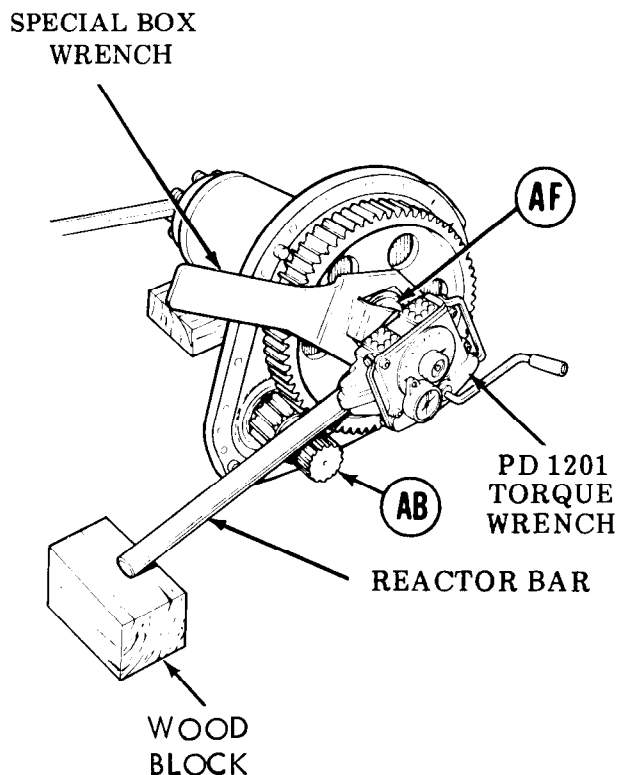

Go on to Sheet 27

FINAL DRIVE REPAIR (Sheet 27 of 30)

66. Using torque wrench, tighten eight screws (AJ) to 50-60 lb-ft (68-81 N·m) in sequence shown.
67. Using torque wrench, retighten screws (AJ) to 95-115 lb-ft (129-156 N·m).
68. Install lockwire on pairs of screws (AJ).

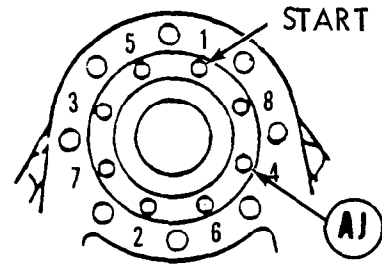
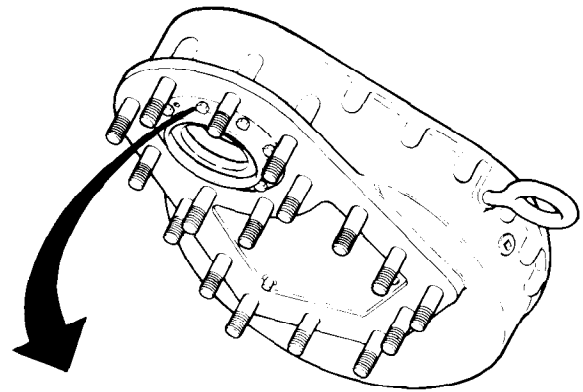

69. Position carrier (N) on wood blocks.
70. Place new gasket (AK) on carrier (N).
71. Using suitable lifting device, position case (U) over carrier (N).
72. Carefully guide pinion gear (AB) thru bearing and seal in case (U) and align case with dowel pins (AL) in carrier (N). Apply pressure evenly to mate case (U) with carrier (N).
73. Install three bolts (AM) through carrier (N) into case (U) to keep units together.

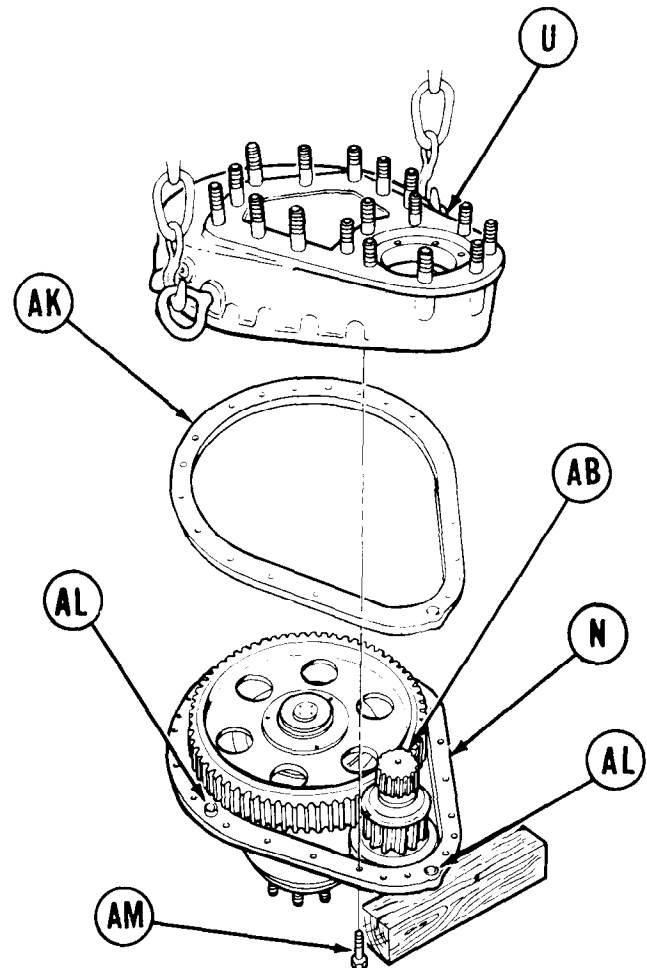

Go on to Sheet 28

FINAL DRIVE REPAIR (Sheet 28 of 30)

74. Using suitable lifting device, position assembled carrier (N) on its side and support with wood blocks.
75. Install remaining 17 bolts (AM) to secure case (U) to carrier (N). Use 7/8 or 1 inch socket as required to tighten bolts.
76. Using torque wrench, tighten 20 bolts (AM) to 110-130 lb-ft (149-176 N.m) in sequence indicated.
77. Using torque wrench, retighten 20 bolts (AM) to 190-230 lb-ft (257-312 N.m) in same sequence.
78. Apply sealing compound (Item 9, Appendix B) to threads of setscrews (AN) and, using 5/16 inch allen wrench, install and tighten four setscrews (AN) into case (U).

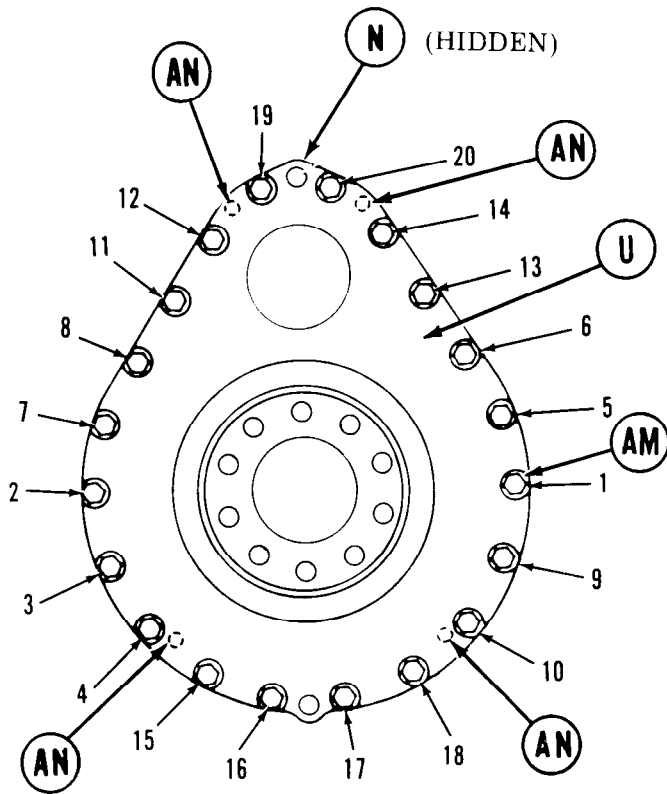

79. If studs (AP or AQ) were removed from case (U) during disassembly or repair, apply sealing compound (Item 9, Appendix B) to stud threads and sealing compound (Item 8, Appendix B) to threads in case (U). Install studs into case (U) so that remaining length above case surface is as listed below:

Studs AP - 2.25 ± 0.06 in. (57.150 ± 1.52 mm)
 Studs AQ - 2.88 ± 0.06 in. (73.152 ± 1.52 mm)
 - 0.00 in. - 0.00 mm

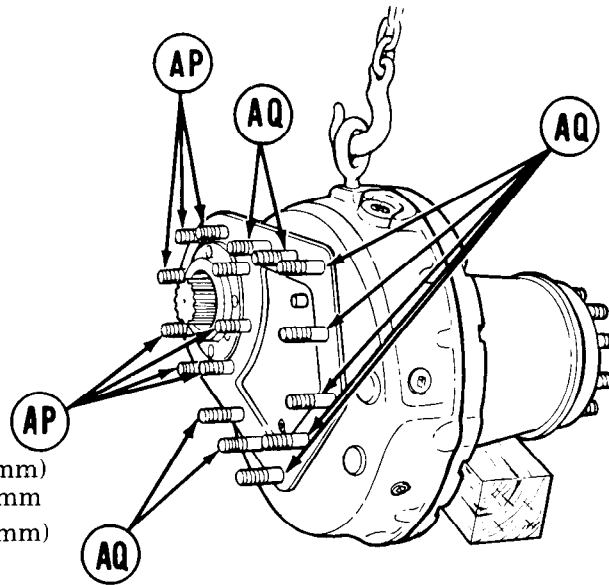

Go on to Sheet 29

FINAL DRIVE REPAIR (Sheet 29 of 30)

80. Apply sealing compound (Item 9, Appendix B) to threads of plugs (AR).
81. Using 1/2 inch drive hinged bar or 5/8 inch allen wrench as necessary, install four plugs (AR) in case (U).
82. Using 3/16 inch allen wrench, install plug (AS) in case (U).
83. Using 7/16 inch wrench, install air pressure valve or vent line elbow (AT) in case (U).
84. Fill final drive with lubricant (LO 5-5420-226-12).
85. Inspect for oil leaks. Correct as necessary.
86. Perform axial play and backlash tests.

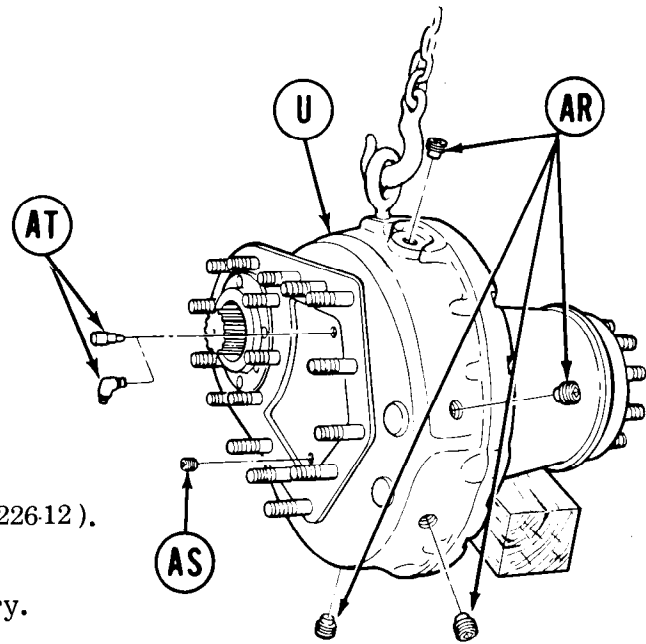
**AXIAL PLAY AND BACKLASH TESTS:****WARNING**

Properly support final drive (A) to prevent movement and possible injury to personnel.

1. Secure C-clamp to pinion shaft (B) with care to prevent damage to pinion shaft spline.
2. Secure dial indicator to final drive stud (C) with dial resting on pinion shaft (B). Set dial to zero.
3. Using C-clamp as a handle, pull pinion shaft (B) up and push down and record dial indicator reading. Repeat procedure four times.
4. If all measurements are between 0.011 to 0.077 inches, (0.279 to 1.956 mm), remove dial indicator and go to step 5. If all measurements are not within tolerance, tag final drive (A) "UNSERVICEABLE (NO AXIAL END PLAY)" and return final drive (A) to supply for depot rebuild.

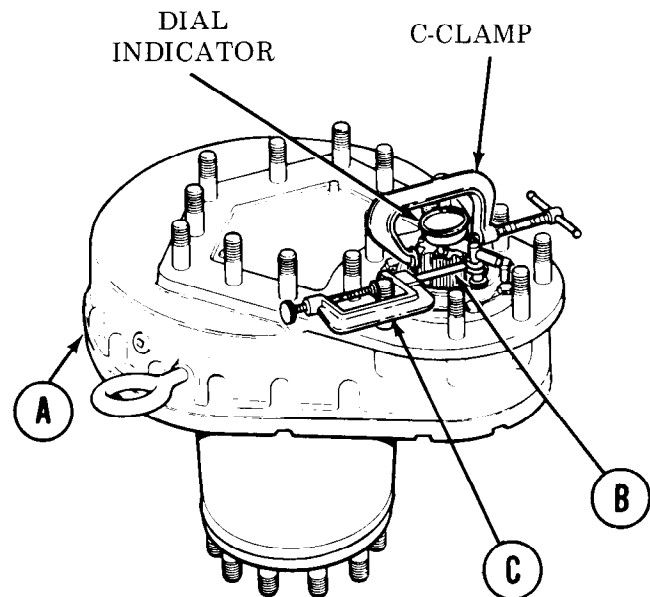

Go on to Sheet 30

FINAL DRIVE REPAIR (Sheet 30 of 30)

5. Using C-clamp, rotate pinion shaft (B) counterclockwise until slight pressure (drag) is felt.

NOTE

Ensure pinion splines are clean and free of chips, burrs, oil, and dirt before installing dial indicator.

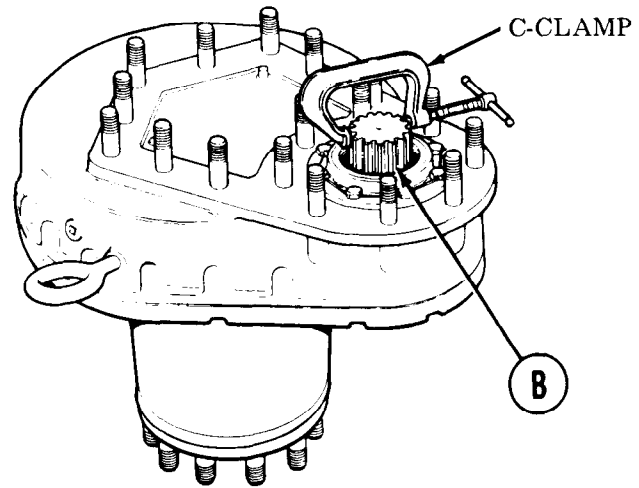

6. Install dial indicator. Set dial indicator to zero.
7. Rotate pinion shaft (B) clockwise until slight pressure (drag) is felt.
8. Record dial indicator reading.
9. Remove dial indicator. Rotate pinion shaft (B) one complete revolution.
10. Repeat steps 5 thru 9 three times.
11. If all four readings are between 0.006 and 0.032 inches (0.15424 and 0.8128 mm), remove C-clamp and install adapter (D). Package final drive (A) for shipment and return to supply. If readings are not within tolerance, go to step 12.

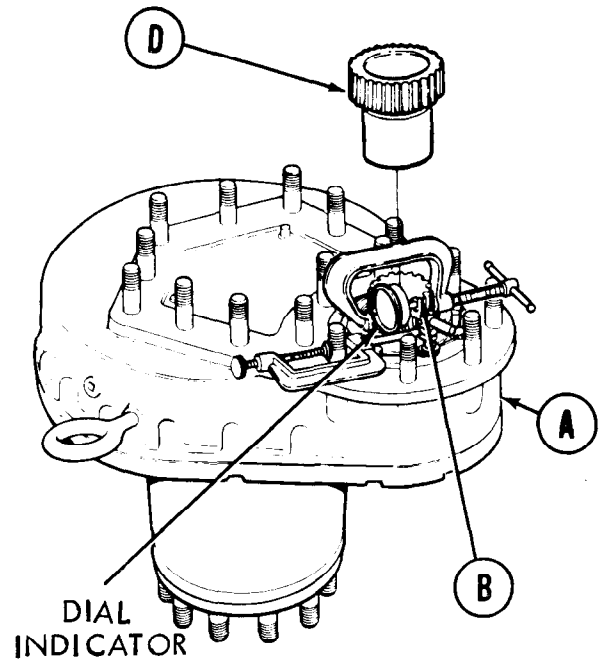

12. Replace pinion gear and drive gear (matched set) (Disassembly steps 1 thru 29) (Assembly steps 54 thru 86). If replacement gears are not within tolerance, tag final drive (A) "UNSERVICEABLE (BACKLASH)" and return to supply for depot rebuild.

End of Task

CHAPTER 8
BRAKE SYSTEM MAINTENANCE

INDEX

Procedure	Page
Brake Master Cylinder Repair	8-2
Brake Slave Cylinder Repair	8-7
Parking Brake Tube Assembly Replacement	8-13
Bulkhead-To-Brake Line Quick-Disconnect Hose Tube Assembly Replacement	8-17

BRAKE MASTER CYLINDER REPAIR (Sheet 1 of 5)

PROCEDURE INDEX

PROCEDURE	PAGE
Disassembly	8-2
Cleaning and Inspection	8-4
Repair	8-4
Assembly	8-5

TOOLS: Inside calipers
 1-1/8 in. open end wrench
 3/8 in. combination box and open end wrench
 3/4 in. combination box and open end wrench
 Vise
 Honing unit set
 Electric drill
 Flat-tip screwdriver (2 required)
 Cross-tip screwdriver

SUPPLIES: Parts kit
 Dry cleaning solvent (Item 12, Appendix B)
 Silicone brake fluid (Item 15, Appendix B)
 Gloves (Item 31, Appendix B)
 Goggles (Item 32, Appendix B)

PRELIMINARY PROCEDURE: Remove master cylinder (TM 5-5420-226-20).

DISASSEMBLY:

NOTE

Tracked vehicle master cylinders are identified with "TANK" stamped on the mounting flange.

1. Place master cylinder (A) in vise (B).

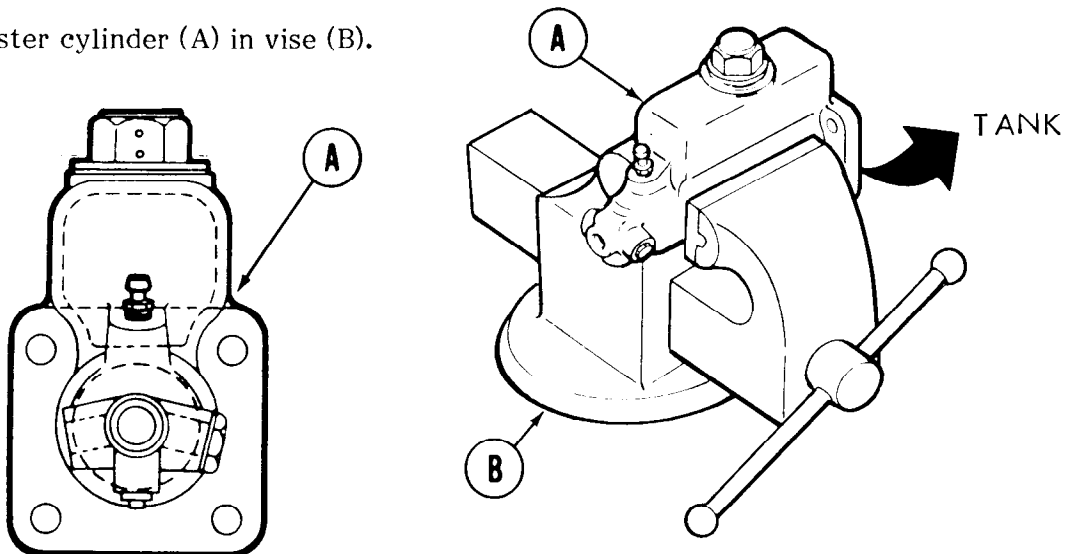

Go on to Sheet 2

BRAKE MASTER CYLINDER REPAIR (Sheet 2 of 5)

2. Using 1-1/8 inch wrench, remove filler cap (C) and gasket (D) from cylinder (A).
3. Using 3/8 inch wrench, remove bleeder valve (E).

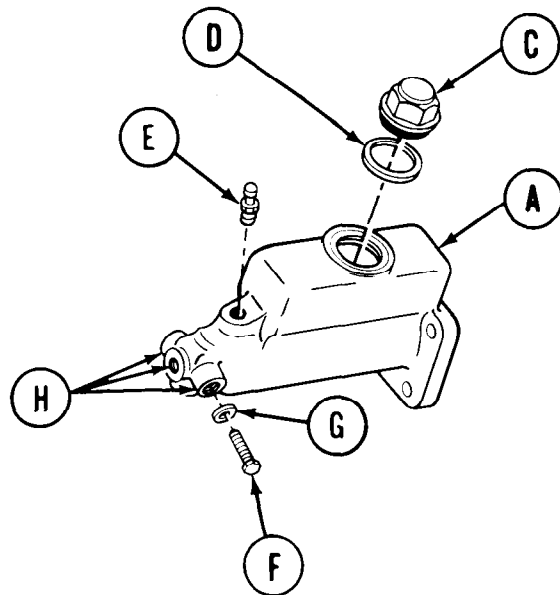

4. Using 3/4 inch wrench, remove plug (F) and gasket (G).

5. Insert cross-tip screwdriver in cylinder (A) and press in piston (H) while removing retaining ring (J) with flat-tip screwdriver.
6. Insert flat-tip screwdriver through hole (K), push out washer (L), piston (H), cap (M), spring (N), and retainer (P).

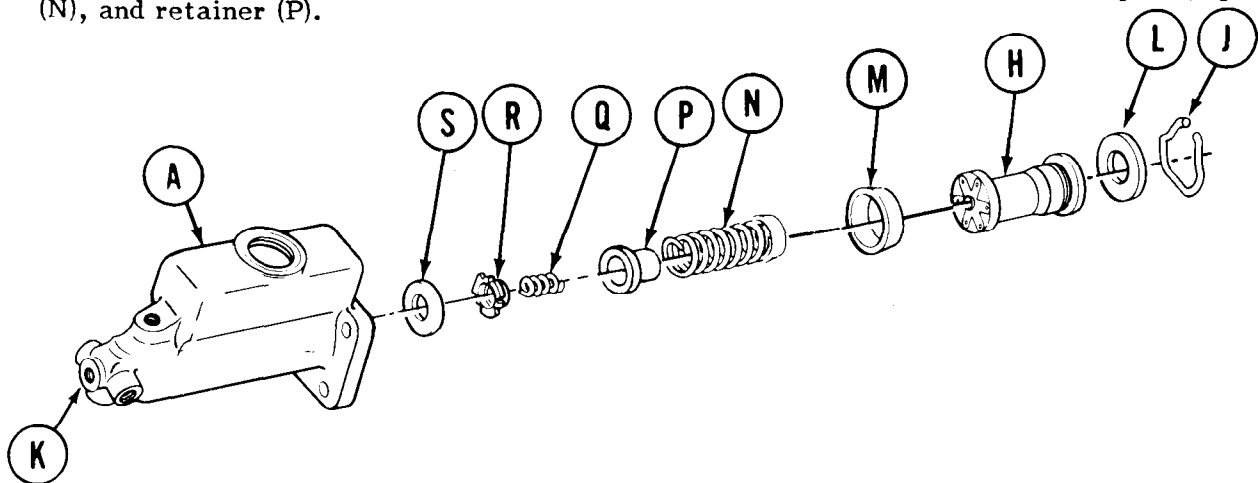

7. Remove retainer (P) from spring (N).
8. Separate spring (Q) from retainer (P) by pressing on valve (R) and turning.
9. Insert screwdriver through hole (K) and remove seat (S) from cylinder (A).

Go on to Sheet 3

TA108530

BRAKE MASTER CYLINDER REPAIR (Sheet 3 of 5)

CLEANING AND INSPECTION:

WARNING

Dry cleaning solvent P-D-680 is toxic and flammable. To avoid injury, wear protective goggles and gloves and use in a well-ventilated area. Avoid contact with skin, eyes, and clothes, and do not breathe vapors. Do not use near open fire or excessive heat. The flash point for Type I dry cleaning solvent is 100°F (38°C) and for Type II is 140°F (60°C). If you become dizzy while using dry cleaning solvent, get fresh air immediately and get medical aid. If contact with eyes is made, wash your eyes with water and get medical aid immediately.

1. Clean all metallic parts in dry cleaning solvent.
2. Visually inspect cylinder bore (A) for scratches, pits, or glazing. Replace cylinder if unserviceable.
3. Visually inspect inside cylinder by looking in hole (B) and check hole pattern (C) on bottom of master cylinder.

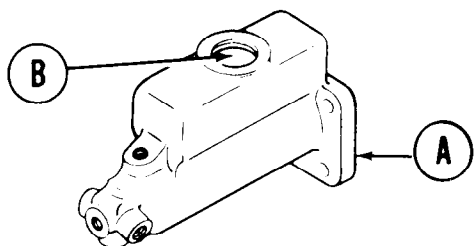

NOTE

Four holes (C) as shown is acceptable.

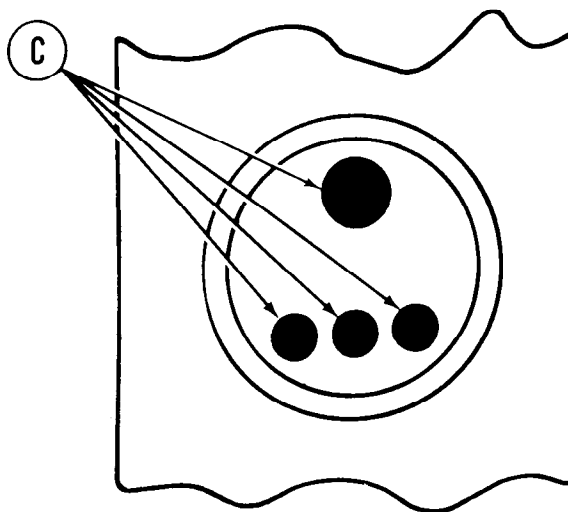

Go on to Sheet 4

BRAKE MASTER CYLINDER REPAIR (Sheet 4 of 5)**NOTE**

Coat cylinder hole, valve seat, and valve cup with hydraulic fluid (Item 15, Appendix B).

ASSEMBLY:

1. Place cylinder (A) in vise with bore facing up.
2. Install seat (B) with flat portion facing down into cylinder (A).

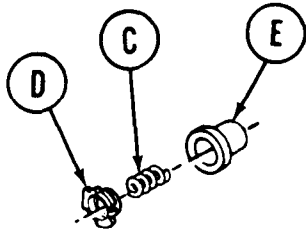
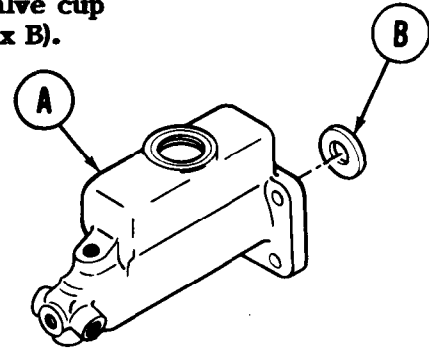

3. Install spring (C) and valve (D) into retainer (E). Press down and turn to seat valve (D) into retainer (E).

4. Place retainer (E) into spring (F).
5. Place cup (G) over end of spring (F).

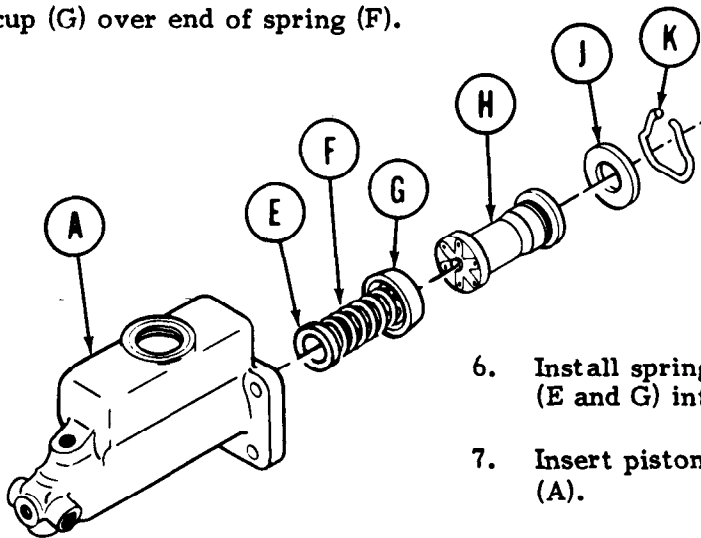

6. Install spring (F) with assembled components (E and G) into cylinder (A).
7. Insert piston (H) and washer (J) into cylinder (A).
8. Using screwdriver, press down on piston (H), install retaining ring (K).

Go on to Sheet 5

TA108532

BRAKE MASTER CYLINDER REPAIR (Sheet 5 of 5)

9. Place cylinder (A) in horizontal position in vise.
10. Using 3/8 inch wrench, install bleeder valve (L).
11. Using 3/4 inch wrench, install gasket (M) and plug (N).
12. Using 1-1/8 inch wrench, install filler cap (P) and gasket (Q).
13. Remove master cylinder (A) from vise.

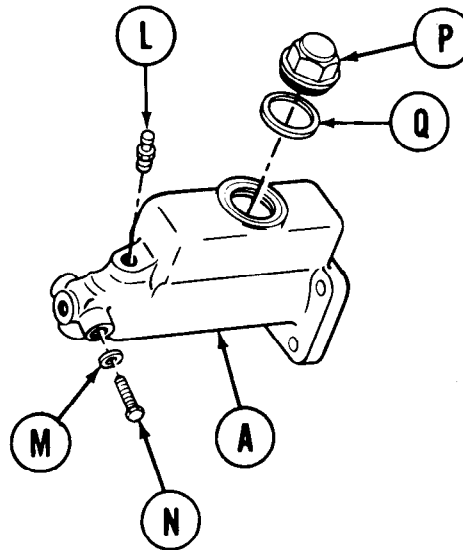

End of Task

TA108533

BRAKE SLAVE CYLINDER REPAIR (Sheet 1 of 6)

PROCEDURE INDEX

PROCEDURE	PAGE
Disassembly	8-7
Cleaning and Inspection	8-9
Repair	8-9
Assembly	8-10

TOOLS:

3/8 in. combination box and open end wrench	Knife
1/2 in. combination box and open end wrench	Hammer
1 in. open end wrench	Vise
Drift punch	Flat-tip screwdriver
Torque wrench with 3/8 in. drive 0-200 lb-in. (0-23 N•m)	Cylinder hone
	9/16 in. combination box and open end wrench
	9/16 in. socket with 3/8 in. drive

SUPPLIES:

- Parts kit (5704212)
- Dry cleaning solvent (Item 12, Appendix B)
- Hydraulic brake fluid (Item 15, Appendix B)
- Rags
- Preformed packing (11626795)
- Screw 3/8-16 UNC 2B
- Masking tape (Item 24, Appendix B)

PRELIMINARY PROCEDURE: Remove brake slave cylinder (TM 5-5420-226-20)

DISASSEMBLY:

- Place slave cylinder (A) in vise (B) for disassembly.

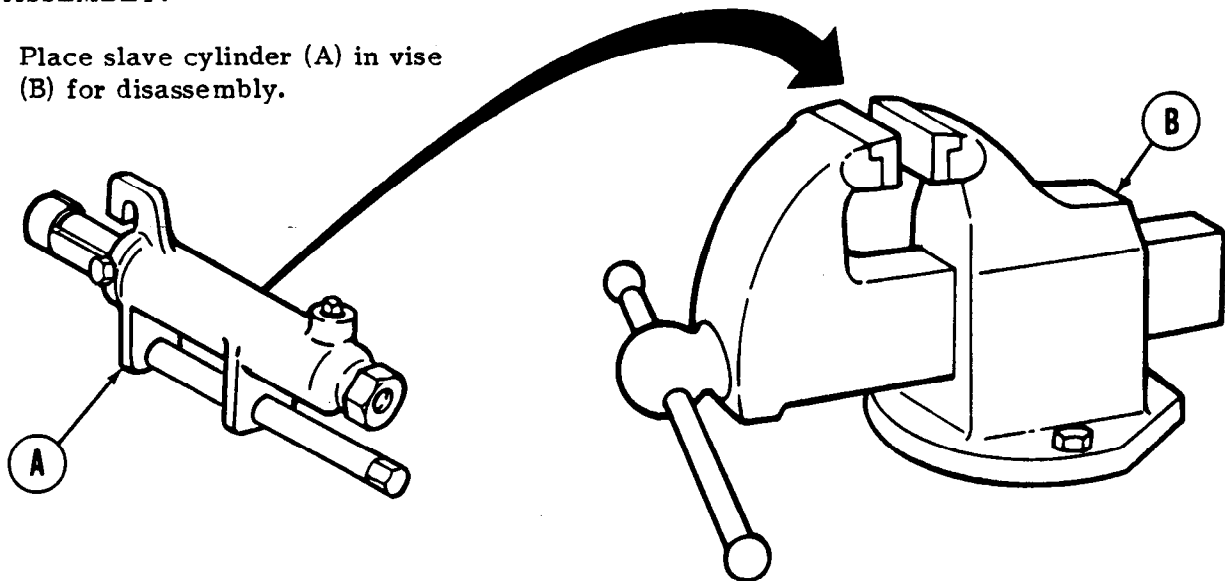

Go on to Sheet 2

TA108534

BRAKE SLAVE CYLINDER REPAIR (Sheet 2 of 6)

CAUTION

Hold tube (D) in position while removing screws as spring is compressed in cylinder.

- Using 1/2 inch wrench, remove two screws (C) holding tube (D) in slave cylinder (A).

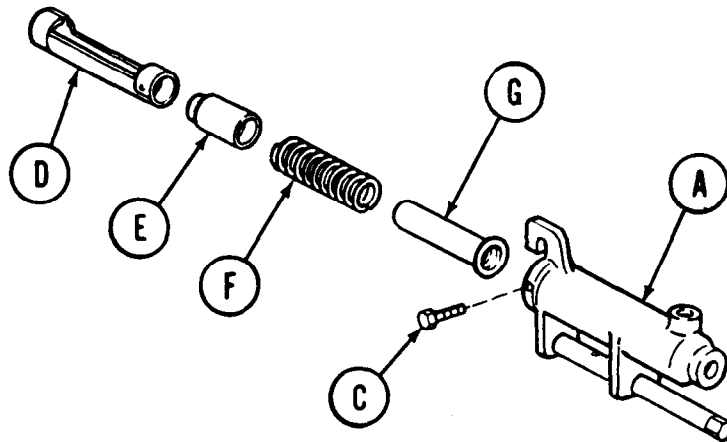

- Remove tube (D), retainer (E), spring (F), and tube (G) from slave cylinder (A). Throw tube (G) and spring (F) away.

- Using 3/8 inch wrench, remove bleeder valve (H) from slave cylinder (A).

- Using 1 inch wrench, remove plug (J) and preformed packing (K). Throw away packing (K).

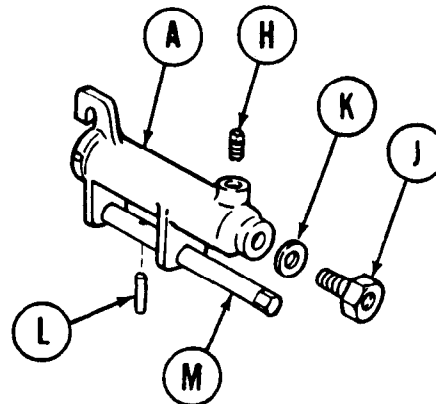

- Move slave cylinder in vise to expose pin (L).

- Using drift punch and hammer, remove pin (L) and remove slave nut (M) from slave cylinder (A).

Go on to Sheet 3

TA108535

BRAKE SLAVE CYLINDER REPAIR (Sheet 3 of 6)

8. Insert screwdriver through hole in cylinder (A) at point (N), and push piston (P) and related parts from slave cylinder (A). Throw away piston (P) and related parts.

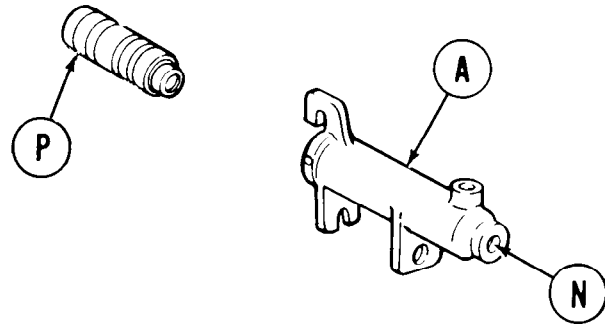
**CLEANING AND INSPECTION:****WARNING**

Dry cleaning solvent P-D-680 is toxic and flammable. To avoid injury, wear protective goggles and gloves and use in a well-ventilated area. Avoid contact with skin, eyes, and clothes, and do not breathe vapors. Do not use near open fire or excessive heat. The flash point for Type I dry cleaning solvent is 100°F (38°C) and for Type II is 140°F (60°C). If you become dizzy while using dry cleaning solvent, get fresh air immediately and get medical aid. If contact with eyes is made, wash your eyes with water and get medical aid immediately.

1. Remove slave cylinder from vise. Clean slave cylinder and parts not discarded using dry cleaning solvent and clean rags.
2. Visually inspect cylinder hole for scratches. Replace slave cylinder if unserviceable.

Go on to Sheet 4

BRAKE SLAVE CYLINDER REPAIR (Sheet 4 of 6)

ASSEMBLY:

NOTE

Late kits include piston (A) with rings (B and C) installed.

1. Coat all kit parts and slave cylinder (D) bore with silicone brake fluid. Install seal (E), ring (F), ring (G), and seal (H) on piston (A).

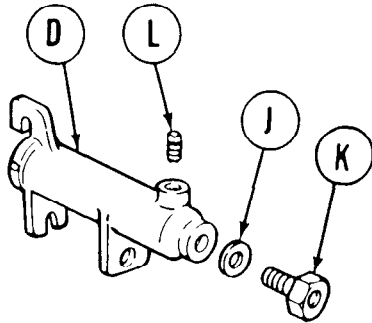
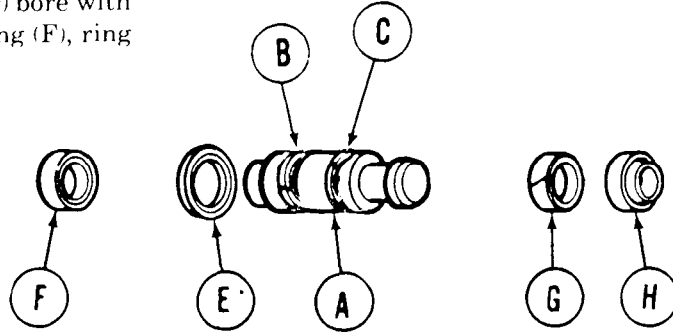

2. Using 1 inch wrench, install new preformed packing (J) and plug (K) in slave cylinder (D).

3. Using 3/8 inch wrench, install bleeder valve (L) in slave cylinder (D).
4. Install assembled piston (A) in slave cylinder (D).

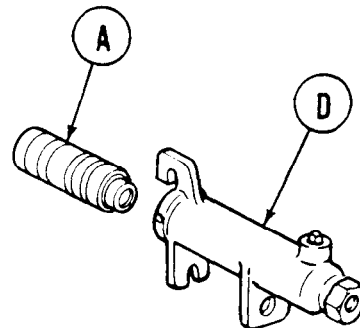

Go on to Sheet 5

BRAKE SLAVE CYLINDER REPAIR (Sheet 5 of 6)

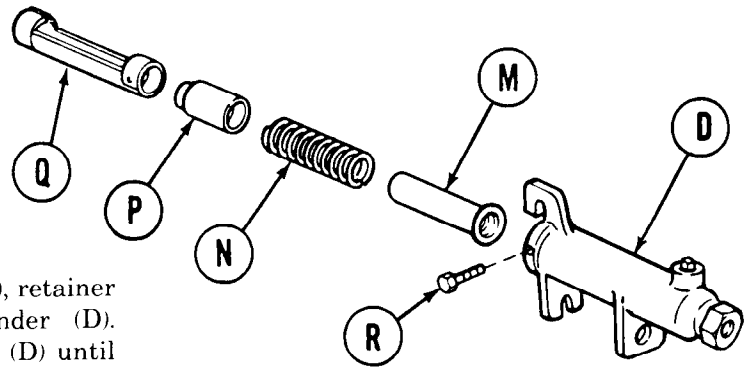

- Assemble new tube (M), new spring (N), retainer (P), and tube (Q) into slave cylinder (D). Compress tube (Q) into slave cylinder (D) until holes in slave cylinder (D) align with holes in tube (Q).

CAUTION

To ensure proper installation, hold spring (N) in position while performing step 6.

- Using 1/2 inch wrench, install and tighten two screws (R) securing tube (Q) in slave cylinder (D).
- Remove slave cylinder (D) from vise.

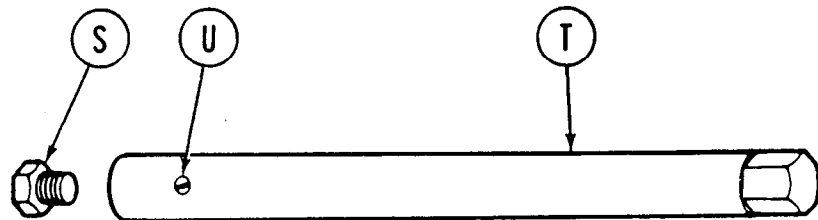

- Thread 3/8-16 UNC 2B screw (S) into end of mounting nut (T). Using 9/16 inch wrench, tighten screw (S).
- Secure mounting nut (T) (head end) in vise.
- Using screwdriver, tighten pellet (U) until 12 to 16 lb-in (.90 to 1.80 N·m) is required to remove screw (S) from nut (T). Remove screw (S) from nut (T).

Go on to Sheet 6

BRAKE SLAVE CYLINDER REPAIR (Sheet 6 of 6)

11. Remove mounting nut (T) from vise.
12. Position mounting nut (T) on slave cylinder (D). Using hammer, install pin (V) through mounting nut (T).
13. If slave cylinder (D) will not be installed immediately, seal open port with masking tape.
14. Install brake slave cylinder (TM 5-5420-226-20)

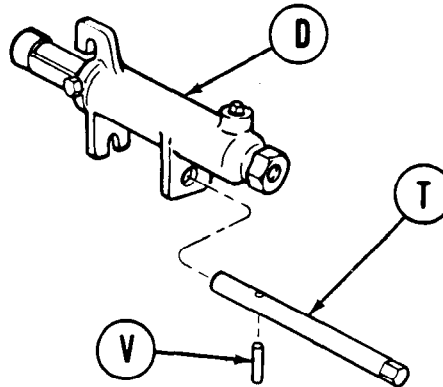

End of Task

CHAPTER 9
SUSPENSION SYSTEM MAINTENANCE
INDEX

PROCEDURE	PAGE
Roadwheel Arm Repair (Number 1 Left and Right)	9-6
Roadwheel Arm Repair (Numbers 2 and 6 Left and Right)	9-12
Roadwheel Arm Repair (Numbers 3, 4, 5 Left and Right)	9-18
Compensating Idler Arm Assembly Repair (Left and Right)	9-24

All data on pages 9-2 thru 9-5 deleted. ■

ROADWHEEL ARM REPAIR (NUMBER 1 LEFT AND RIGHT) (Sheet 1 of 6)

PROCEDURE INDEX

PROCEDURE	PAGE
Disassembly	9-6
Assembly	9-9

TOOLS: Hammer
 Chisel
 Arbor press
 Drive collar bushing 4 in. inside dia. 8 in. lg.
 Drive collar bushing 4-9/16 in. inside dia. 10 in. lg.
 Drive collar bushing 6 in. inside dia. 12 in. lg.
 Oxygen - Acetylene Torch

SPECIAL TOOLS: Shock absorber bearing replacer (Item 9, Chapter 2, Section I)
 Bearing tool assembly (Item 10, Chapter 2, Section I)
 Bearing driver (Item 11, Chapter 2, Section I)

SUPPLIES: Crocus cloth (Item 3, Appendix B)
 Gloves (Item 31, Appendix B)
 Goggles (Item 32, Appendix B)

PERSONNEL: Two

REFERENCE: TM 5-5420-226-20

PRELIMINARY PROCEDURES: Remove hub and bearings (TM 5-5420-226-20)
 Remove roadwheel arm (TM 5-5420-226-20)

DISASSEMBLY:

NOTE

Roadwheel arm has two spindles, one spindle end is tapered and is referred to as the lower spindle. The other spindle is not tapered and is referred to as the upper spindle.

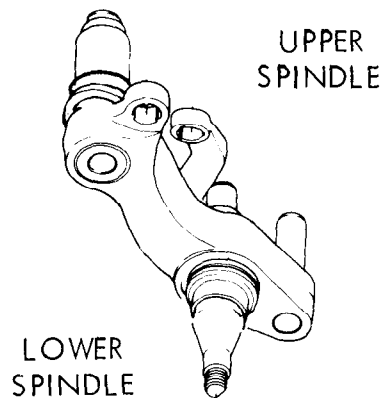

Go on to Sheet 2

ROADWHEEL ARM REPAIR (NUMBER 1 LEFT AND RIGHT) (Sheet 2 of 6)

1. Place roadwheel arm assembly on work bench.
2. Using oxygen-acetylene torch as a heat source, apply heat to spacer (A). Using hammer and chisel, drive spacer (A) off lower spindle (B) of roadwheel arm (C). Throw spacer (A) away. ■
3. Examine bearing surface of lower spindle (B) for any cuts or marks made during removal of spacer (A).
4. Using crocus cloth (Item 3, Appendix B), smooth cuts or marks made on lower spindle (B) during removal. ■

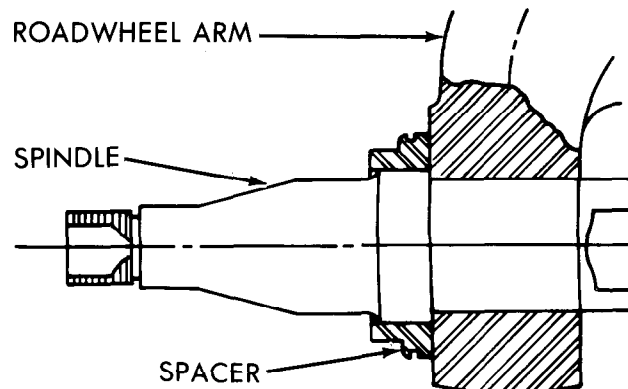
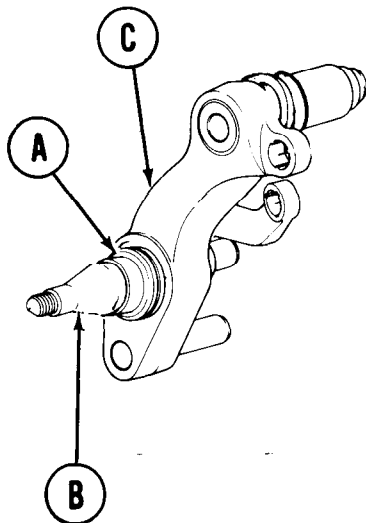

Go on to Sheet 3

ROADWHEEL ARM REPAIR (NUMBER 1 LEFT AND RIGHT) (Sheet 3 of 6)

- 5. Using oxygen-acetylene torch as a heat source, apply heat to spacer (D). Using hammer and chisel, drive spacer (D) and deflector (F) off spindle (E). Throw spacer (D) and deflector (F) away.

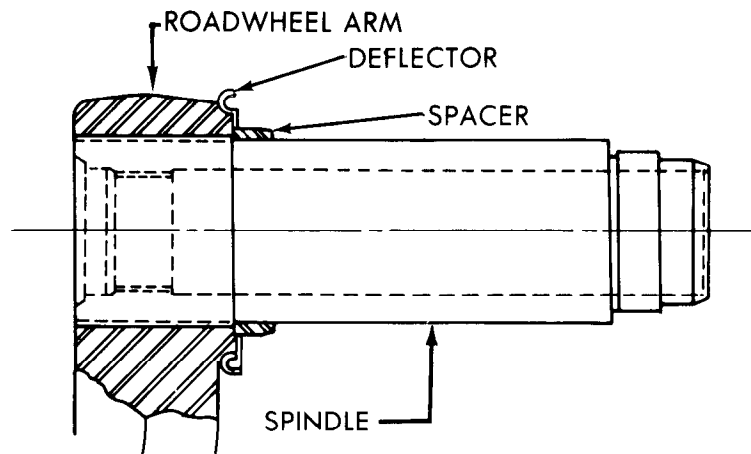
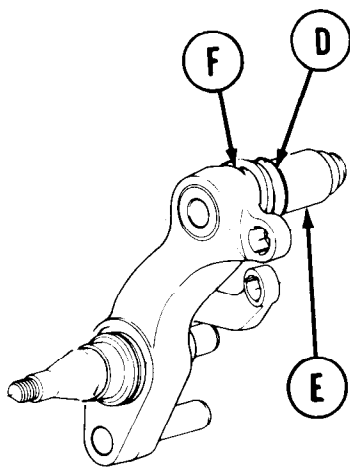

- 6. Examine bearing surface of upper spindle (E) for any cuts or marks made during removal of spacer (D) and deflector (F).
- 7. Using crocus cloth (Item 3, Appendix B), smooth cuts or marks made on upper spindle (E) during removal.

■ Go on to Sheet 3.1

ROADWHEEL ARM REPAIR (NUMBER 1 LEFT AND RIGHT) (Sheet 3.1 of 6)

8. Using hammer and chisel, cut off stakes on three places each side of shock absorber bearing (G) and track adjusting link bearing (H).

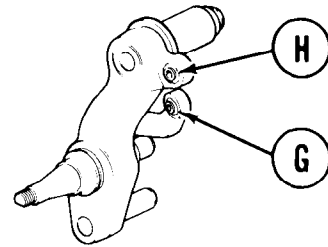

9. Install replacer on bearing (G). Turn replacer nut until bearing (G) is removed. Throw bearing (G) away.

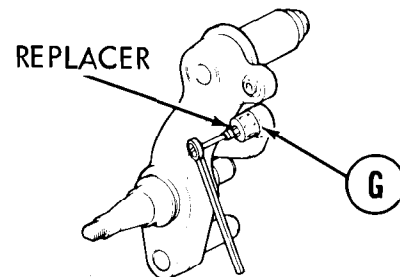

10. Install bearing driver on bearing (H). Turn nut of bearing driver until bearing (H) is removed. Throw bearing (H) away.

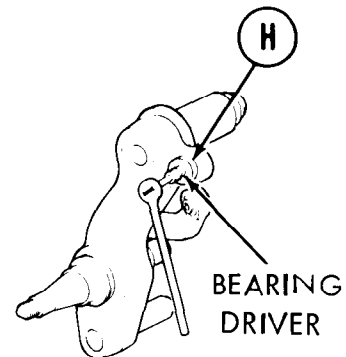

Go on to Sheet 3.2

ROADWHEEL ARM REPAIR (NUMBER 1 LEFT AND RIGHT) (Sheet 3.2 of 6)

ASSEMBLY:

1. Position shock absorber bearing (A) on arm (B). Install replacer over bearing (A) and arm (B). Turn replacer nut until bearing (A) is centered in arm (B). Remove replacer.
2. Stake bearing (A) to arm (B) at three equally spaced locations on each side of bearing (A).

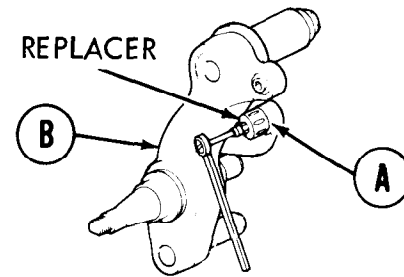

- 1.2. Position bearing (C) on arm (B). Install bearing driver over bearing (C). Turn nut of bearing driver until bearing (C) is centered in arm (B). Remove bearing driver.
- 1.3. Stake bearing (C) to arm (B) at three equally spaced locations on each side of bearing (C).

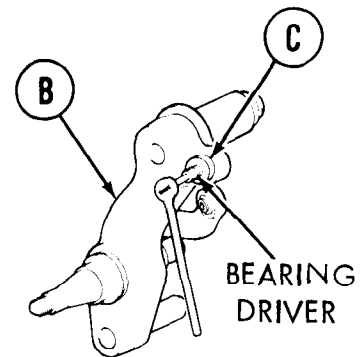

Go on to Sheet 4

ROADWHEEL ARM REPAIR (NUMBER 1 LEFT AND RIGHT) (Sheet 4 of 6)

- 1.4. Using two persons, position roadwheel arm (A) on arbor press.

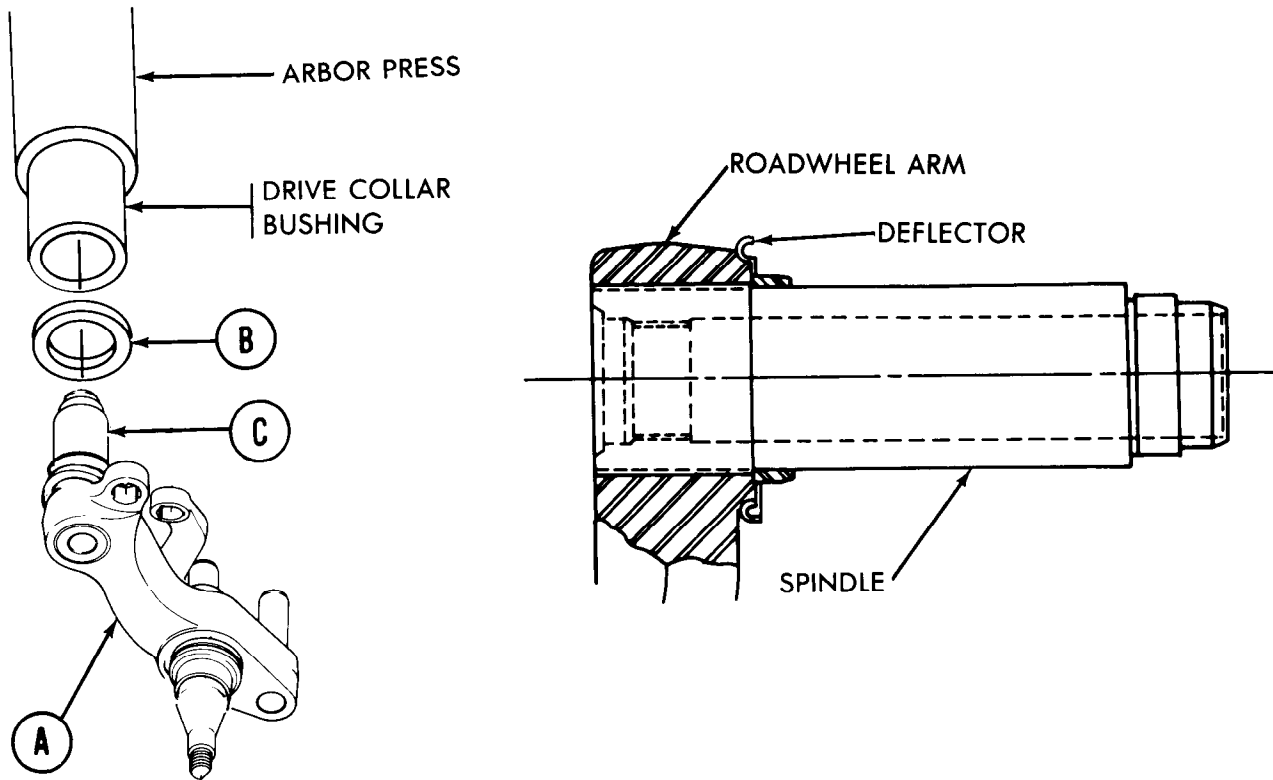

2. Position deflector (B) over roadwheel arm upper spindle (C).
3. Position 6 inch inside diameter drive collar bushing over spindle (C) onto deflector (B) and, using arbor press, drive deflector (B) onto upper spindle (C) of roadwheel arm (A).

NOTE

Seat deflector firmly all the way to the bottom of the upper spindle.

Go on to Sheet 5

ROADWHEEL ARM REPAIR (NUMBER 1 LEFT AND RIGHT) (Sheet 5 of 6)

4. Position spacer (D) over roadwheel arm upper spindle (C).
5. Position 4-9/16 inch inside diameter drive collar bushing over spacer (D).

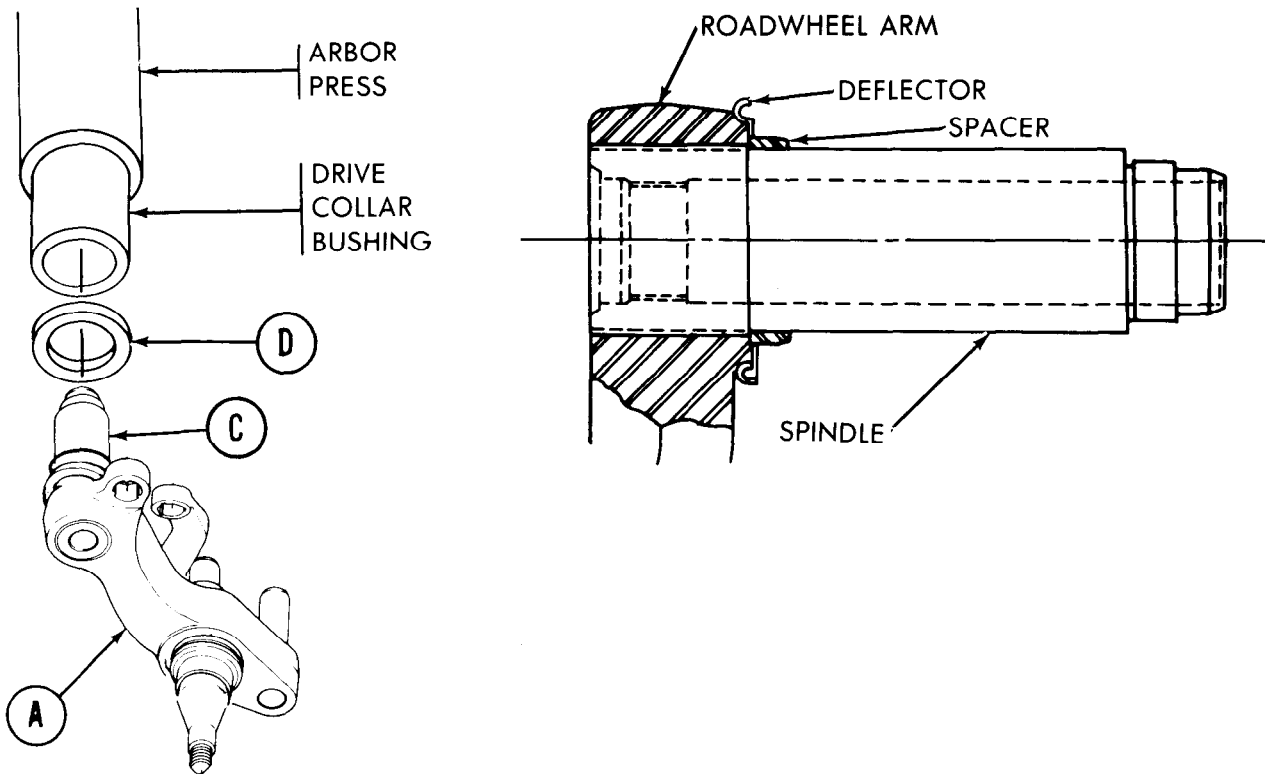

6. Using arbor press, drive spacer (D) onto upper spindle (C) of roadwheel arm (A).

NOTE

Seat spacer firmly all the way down upper spindle against deflector.

Go on to Sheet 6

TA108027

ROADWHEEL ARM REPAIR (NUMBER 1 LEFT AND RIGHT) (Sheet 6 of 6)

7. Using two persons, reposition roadwheel arm (A) on arbor press.
8. Position spacer (E) over roadwheel arm lower spindle (F).

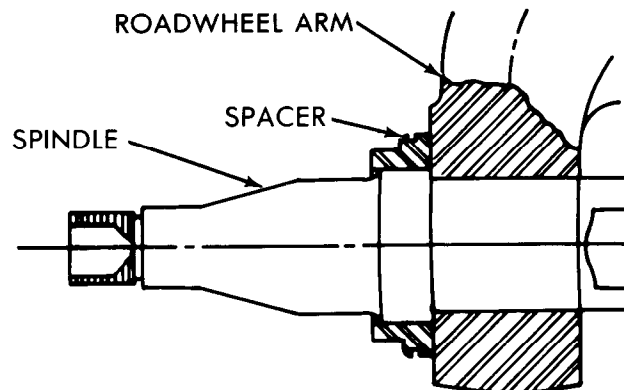
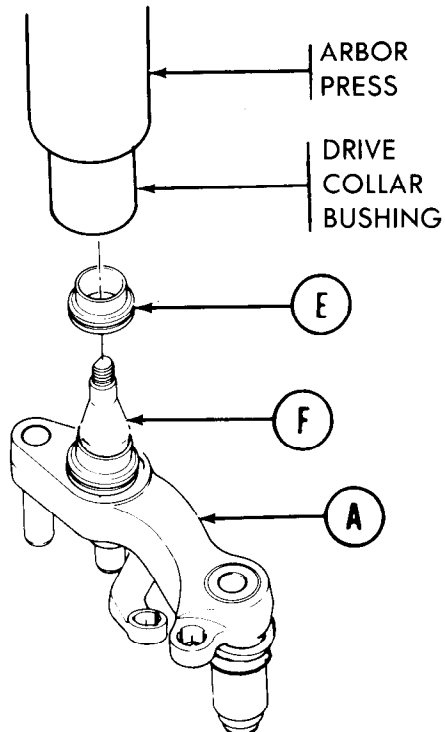

9. Position 4 inch inside diameter drive collar bushing over spacer (E).
10. Using arbor press, drive spacer (E) onto upper spindle (F) of roadwheel arm (A).

NOTE

Seat spacer firmly all the way to the bottom of the lower spindle.

11. Install roadwheel arm (TM 5-5420-226-20).
12. Install hub and bearings (TM 5-5420-226-20).

End of Task

TA108028

ROADWHEEL ARM REPAIR (NUMBERS 2 AND 6 LEFT AND RIGHT) (Sheet 1 of 6)

PROCEDURE INDEX

PROCEDURE	PAGE
Disassembly	9-12
Assembly	9-14.1

TOOLS: Hammer
 Chisel
 Arbor Press
 Drive collar bushing 4 in. inside dia. 8 in. lg.
 Drive collar bushing 4-9/16 in. inside dia. 10 in. lg.
 Drive collar bushing 6 in. inside dia. 12 in. lg.
 Oxygen-acetylene torch

SPECIAL TOOLS: Shock absorber bearing replacer (Item 9, Chapter 2, Section 1)

SUPPLIES: Crocus cloth (Item 3, Appendix B)

PERSONNEL: Two

REFERENCE: TM 5-5420-226-20

PRELIMINARY PROCEDURES: Remove hub and bearings (TM 5-5420-226-20)
 Remove roadwheel arm (TM 5-5420-226-20)

DISASSEMBLY:

NOTE

Roadwheel arm has two spindles. One spindle end is tapered and is referred to as the lower spindle. The other spindle is not tapered and is referred to as the upper spindle.

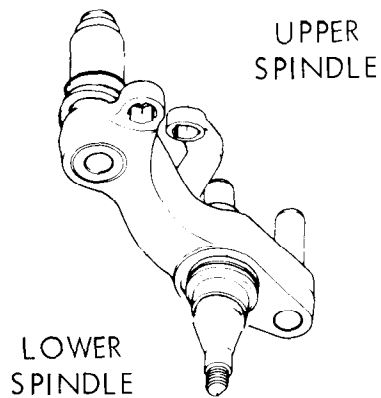

Go on to Sheet 2

ROADWHEEL ARM REPAIR (NUMBERS 2 AND 6 LEFT AND RIGHT) (Sheet 2 of 6)

1. Place roadwheel arm assembly on work bench.
2. Using oxygen-acetylene torch as a heat source, apply heat to spacer (A). Using hammer and chisel, drive spacer (A) off lower spindle (B) of roadwheel arm (C). Throw spacer (A) away.
3. Examine bearing surface of lower spindle (B) for any cuts or marks made during removal of spacer (A).
4. Using crocus cloth (Item 3, Appendix B), smooth cuts or marks made on lower spindle (B) during removal.

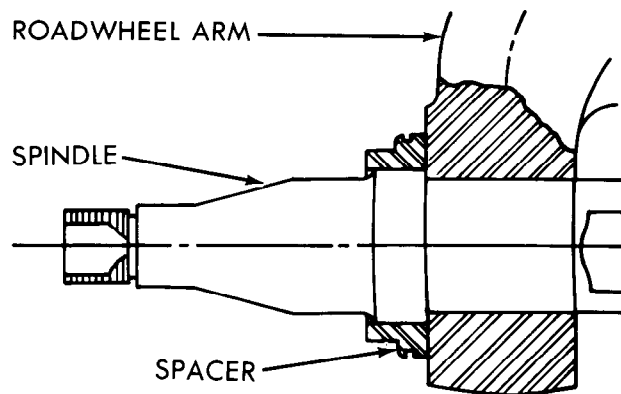
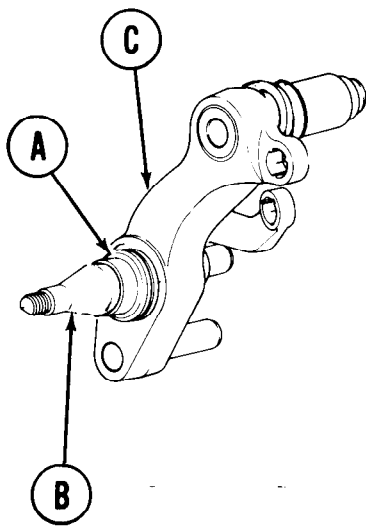

Go on to Sheet 3

ROADWHEEL ARM REPAIR (NUMBERS 2 AND 6 LEFT AND RIGHT) (Sheet 3 of 6)

5. Using oxygen-acetylene torch as a heat source, apply heat to spacer (D). Using hammer and chisel, drive spacer (D) and deflector (F) off upper spindle (E). Throw spacer (D) and deflector (F) away.

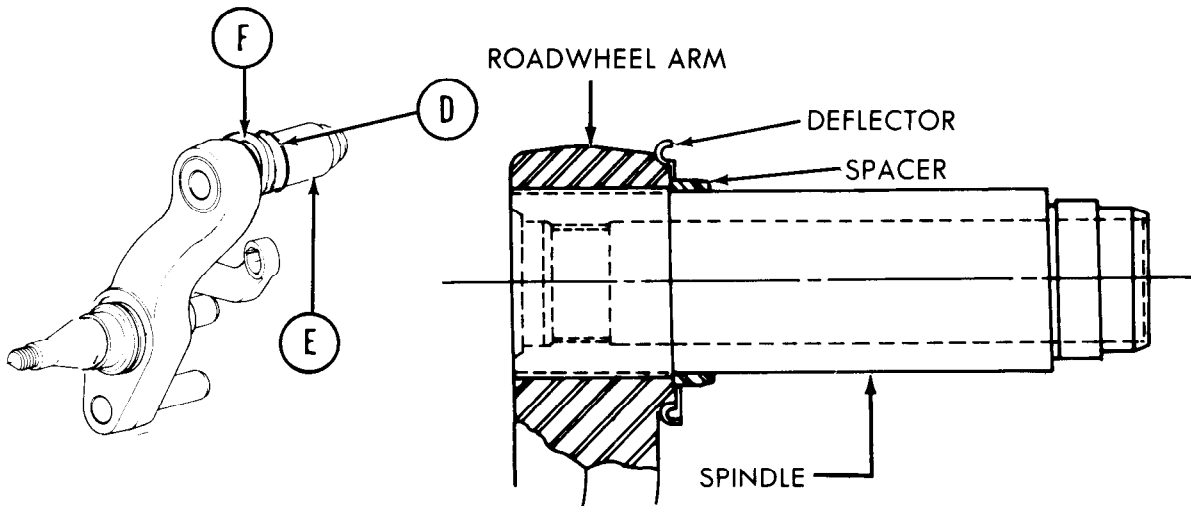

6. Examine bearing surface of upper spindle (E) for any cuts or marks made during removal of spacer (D) and deflector (F).
7. Using crocus cloth (Item 3, Appendix B), smooth cuts or marks made on upper spindle (E) during removal.

Go on to Sheet 3.1

ROADWHEEL ARM REPAIR (NUMBERS 2 AND 6 LEFT AND RIGHT) (Sheet 3.1 of 6)

8. Using hammer and chisel, cut off stakes at three places on each side of shock absorber mount (G).

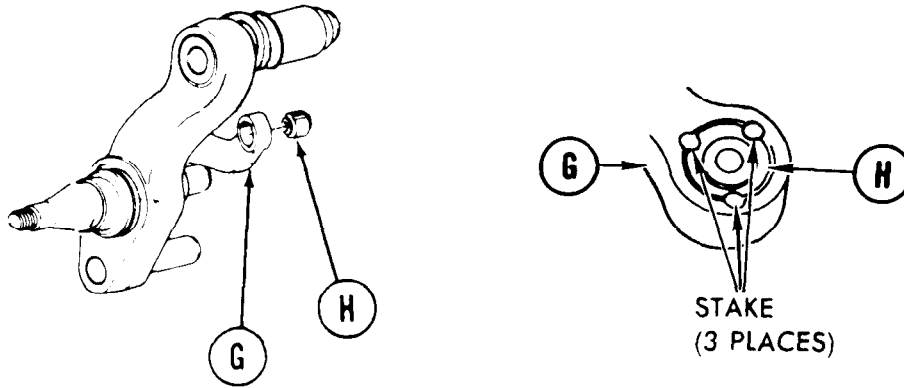

9. Using shock absorber bearing replacer, remove bearing (H) from shock absorber mount (G). Throw bearing (H) away.

ASSEMBLY:

1. Using shock absorber bearing replacer, install bearing (A) in shock absorber mount (B).

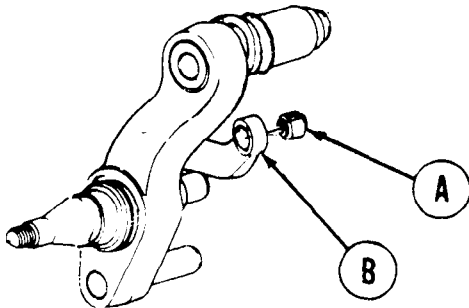

- 1.1. Using hammer and chisel, stake both sides of mounts (B) in three places.

Go on to Sheet 4



ROADWHEEL ARM REPAIR (NUMBERS 2 AND 6 LEFT AND RIGHT) (Sheet 4 of 6)

1.2. Using two persons, position roadwheel arm (A) on arbor press.

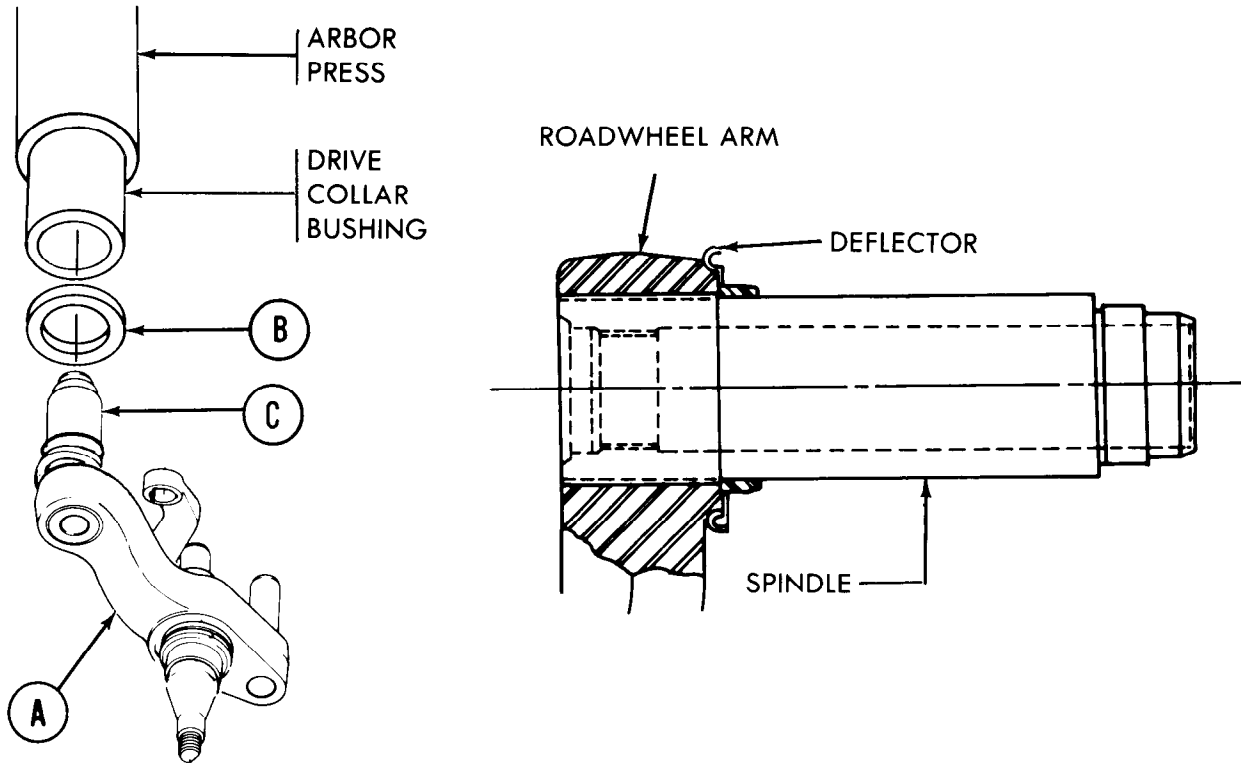

2. Position deflector (B) over roadwheel arm upper spindle (C).
3. Position 6 inch inside diameter drive collar bushing over upper spindle (C) onto deflector (B) and, using arbor press, drive deflector (B) onto upper spindle (C) of roadwheel arm (A).

NOTE

Seat deflector firmly all the way to the bottom of the spindle.

Go on to Sheet 5

ROADWHEEL ARM REPAIR (NUMBERS 2 AND 6 LEFT AND RIGHT) (Sheet 5 of 6)

4. Position spacer (D) over roadwheel arm upper spindle (C).
5. Position 4-9/16 inch inside diameter drive collar bushing over spacer (D).

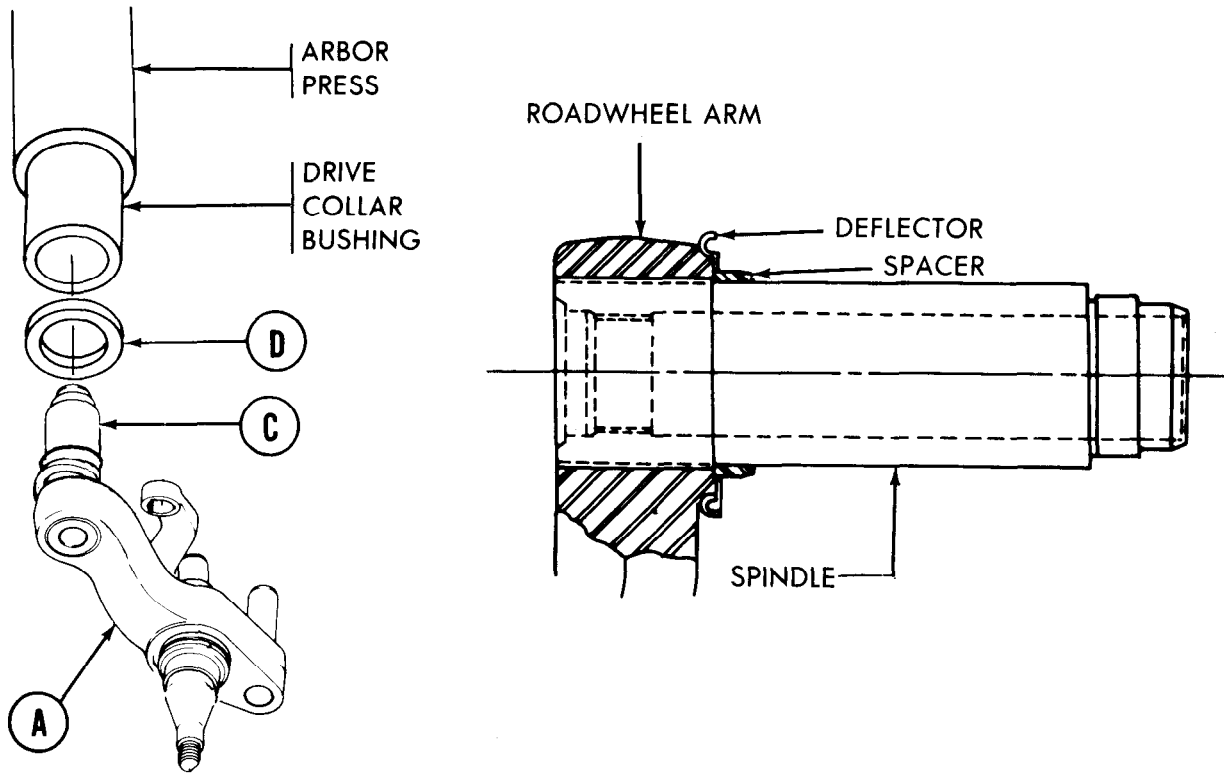

6. Using arbor press, drive spacer (D) onto upper spindle (C) of roadwheel arm (A).

NOTE

Seat spacer firmly all the way down upper spindle against deflector.

Go on to Sheet 6

TA108033

ROADWHEEL ARM REPAIR (NUMBERS 2 AND 6 LEFT AND RIGHT) (Sheet 6 of 6)

7. Reposition roadwheel arm (A) on arbor press.
8. Position spacer (E) over roadwheel arm lower spindle (F).

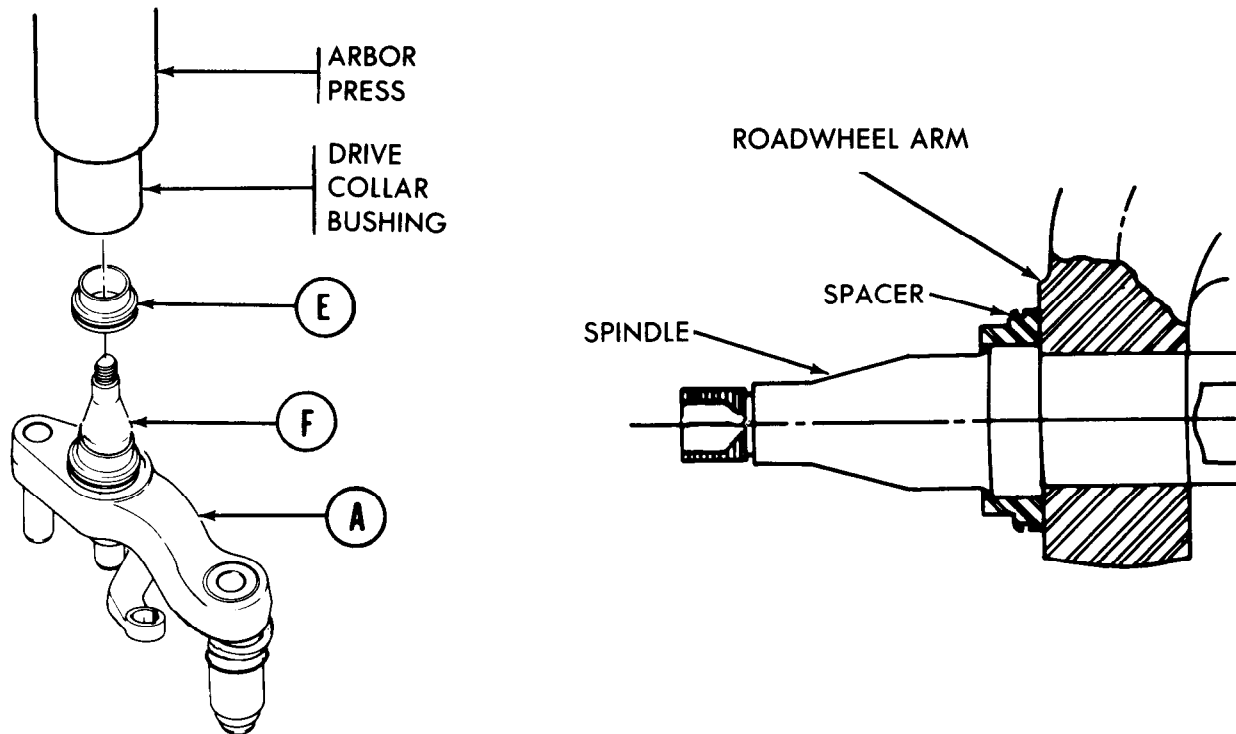

9. Position 4 inch inside diameter drive collar bushing over spacer (E).
10. Using arbor press, drive spacer (E) onto lower spindle (F) of roadwheel arm (A).

NOTE

Seat spacer firmly all the way to the bottom of the lower spindle.

11. Install roadwheel arm (TM 5-5420-226-20).
12. Install hub and bearings (TM 5-5420-226-20).

End of Task

TA108034

ROADWHEEL ARM REPAIR (NUMBERS 3, 4, 5 LEFT AND RIGHT) (Sheet 1 of 6)

PROCEDURE INDEX

PROCEDURE	PAGE
Disassembly	9-18
Assembly	9-21

TOOLS: Hammer
 Chisel
 Arbor press
 Drive collar bushing 4 in. inside dia. 8 in. lg.
 Drive collar bushing 4-9/16 in. inside dia. 10 in. lg.
 Drive collar bushing 6 in. inside dia. 12 in. lg.
 Welding outfit

SUPPLIES: Crocus cloth (Item 4, Appendix B)

PERSONNEL: Two

REFERENCE: TM 5-5420-226-20

PRELIMINARY PROCEDURE: Remove roadwheel arm (TM 5-5420-226-20)

DISASSEMBLY:

NOTE

Roadwheel arm has two spindles. One spindle end is tapered and is referred to as the lower spindle. The other spindle is not tapered and is referred to as the upper spindle.

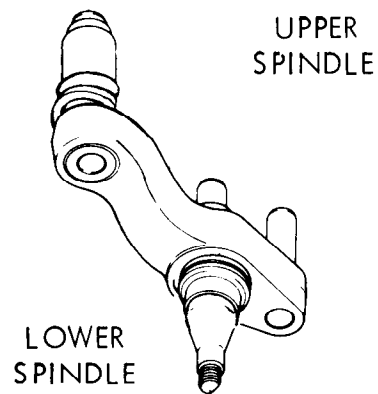

Go on to Sheet 2

TA108035

ROADWHEEL ARM REPAIR (NUMBERS 3, 4, 5 LEFT AND RIGHT) (Sheet 2 of 6)

1. Using two persons, place roadwheel arm assembly on work bench.
2. Using welding outfit as a heat source, apply heat to spacer (A). Using hammer and chisel, drive spacer (A) off lower spindle (B) of roadwheel arm (C). Throw spacer (A) away.
3. Examine bearing surface of lower spindle (B) for any cuts or marks made during removal of spacer (A).
4. Using crocus cloth (Item 4, Appendix B), smooth cuts or marks made on lower spindle (B) during removal.

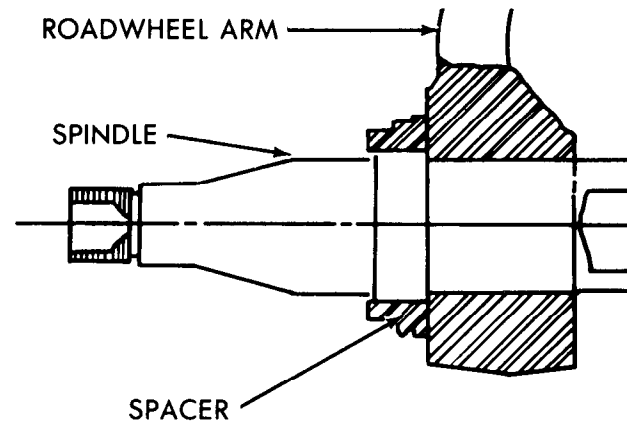
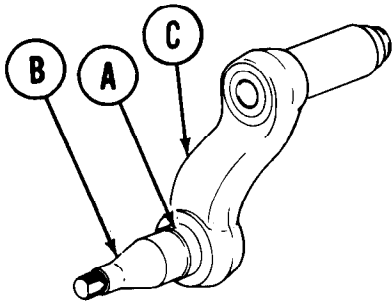

Go on to Sheet 3

TA108036

ROADWHEEL ARM REPAIR (NUMBERS 3, 4, 5 LEFT AND RIGHT) (Sheet 3 of 6)

5. Using welding outfit as a heat source, apply heat to spacer (D). Using hammer and chisel, drive spacer (D) and deflector (F) off upper spindle (E). Throw spacer (D) and deflector (F) away.

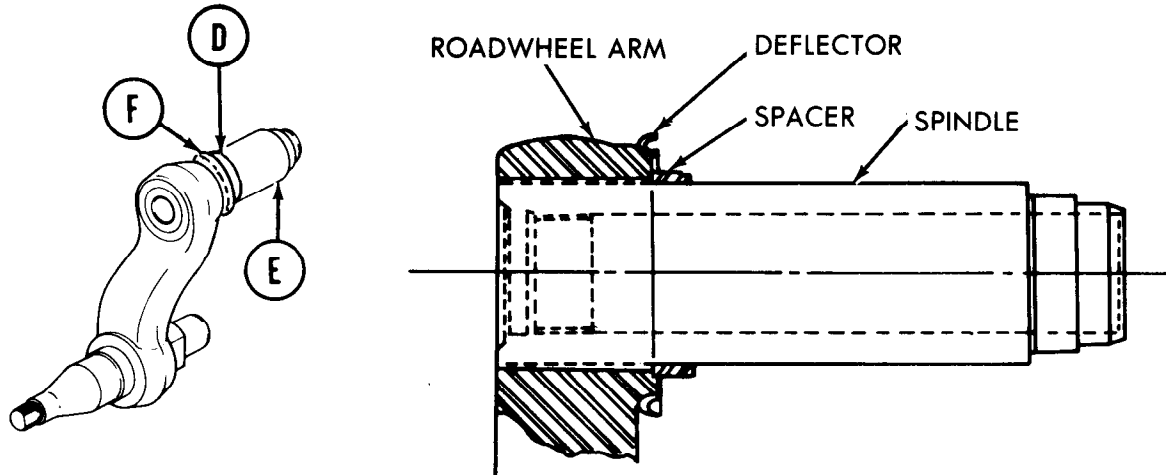

6. Examine bearing surface of upper spindle (E) for any cuts or marks made during removal of spacer (D) and deflector (F).
7. Using crocus cloth (Item 4, Appendix B), smooth cuts or marks made on upper spindle (E) during removal.

ROADWHEEL ARM REPAIR (NUMBERS 3, 4, 5 LEFT AND RIGHT) (Sheet 4 of 6)

ASSEMBLY:

- Using two persons, position roadwheel arm (A) on arbor press.

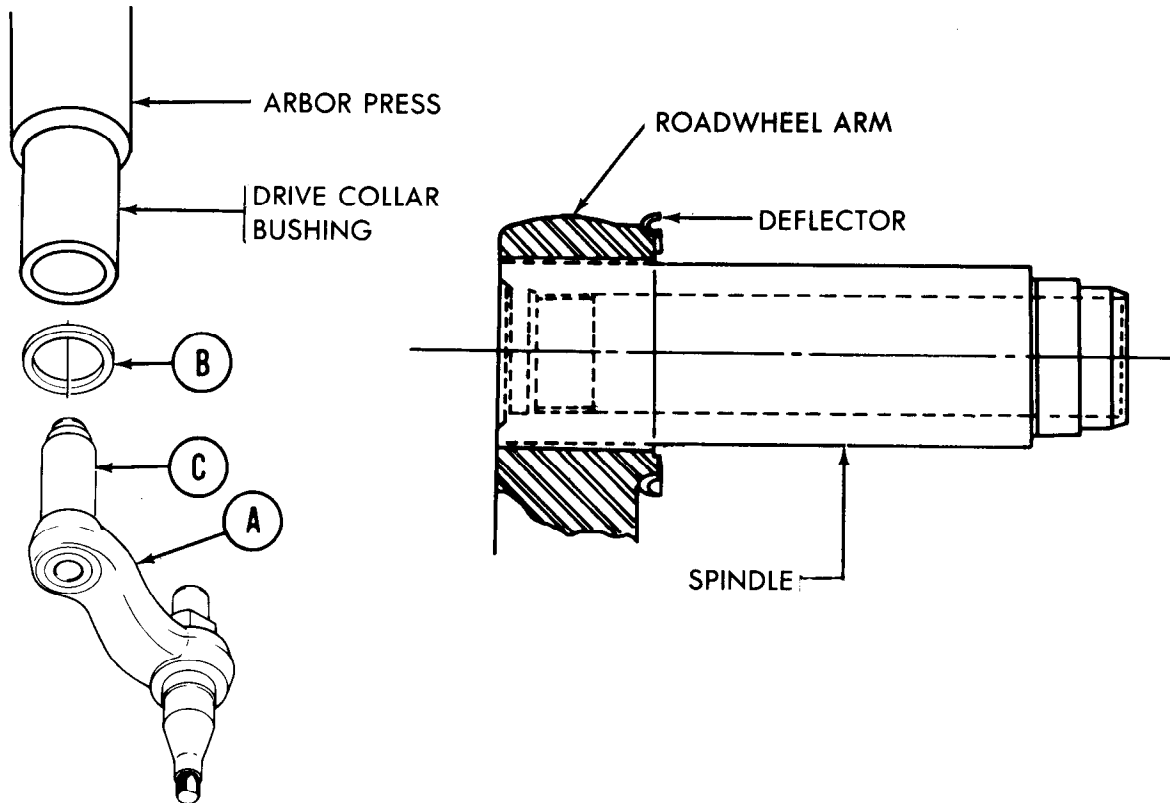

- Position deflector (B) over roadwheel arm upper spindle (C).
- Position 6 inch inside diameter drive collar bushing over upper spindle (C) onto deflector (B) and, using arbor press, drive deflector (B) onto spindle (C) of roadwheel arm (A).

NOTE

Seat deflector firmly all the way to the bottom of the upper spindle.

Go on to Sheet 5

TA108038

ROADWHEEL ARM REPAIR (NUMBERS 3, 4, 5 LEFT AND RIGHT) (Sheet 5 of 6)

4. Position spacer (D) over roadwheel arm upper spindle (C).
5. Position 4-9/16 inch inside diameter drive collar bushing over spacer (D).
6. Using arbor press, drive spacer (D) onto upper spindle (C) of roadwheel arm (A).

NOTE

Seat spacer firmly all the way down upper spindle against deflector.

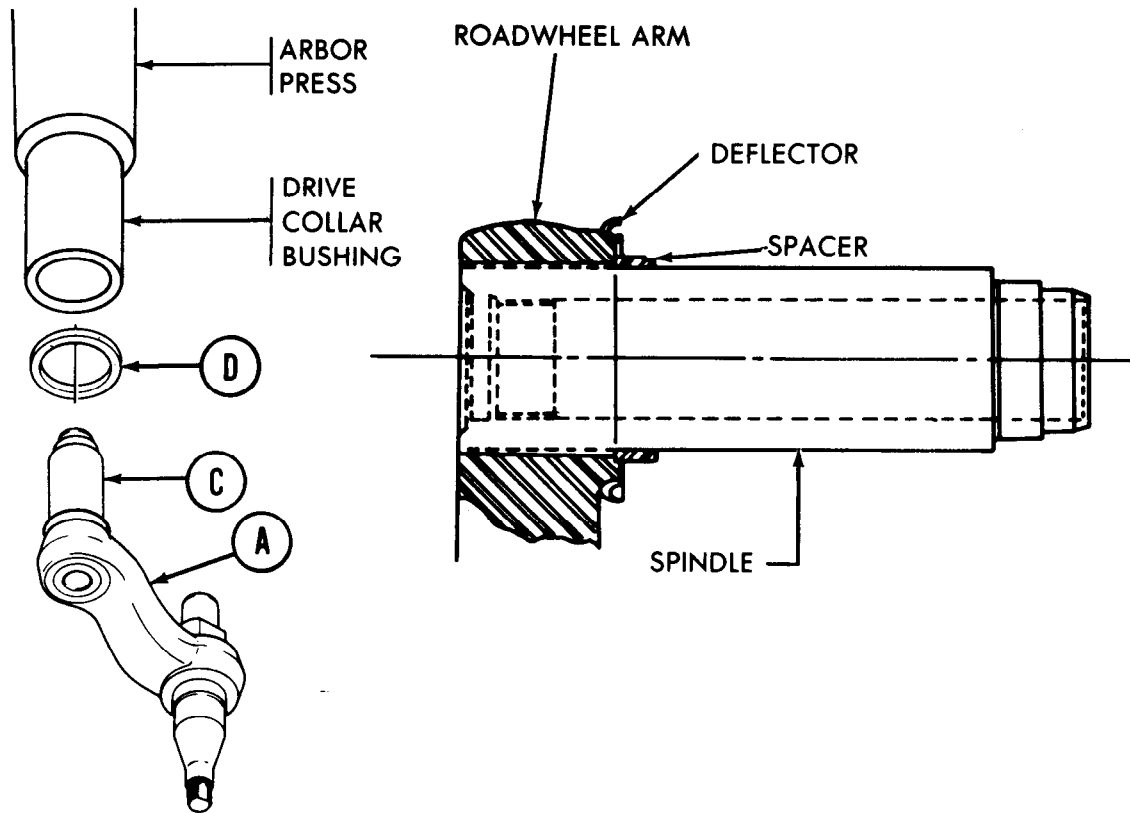

Go on to Sheet 6

TA108039

ROADWHEEL ARM REPAIR (NUMBERS 3, 4, 5 LEFT AND RIGHT) (Sheet 6 of 6)

7. Using two persons, reposition roadwheel arm on arbor press.
8. Position spacer (E) over roadwheel arm lower spindle (F).
9. Position 4 inch inside diameter drive collar bushing over spacer (E).

NOTE

Seat spacer firmly all the way down to the bottom of the lower spindle.

10. Using arbor press, drive spacer (E) onto lower spindle (F) of roadwheel arm (A).

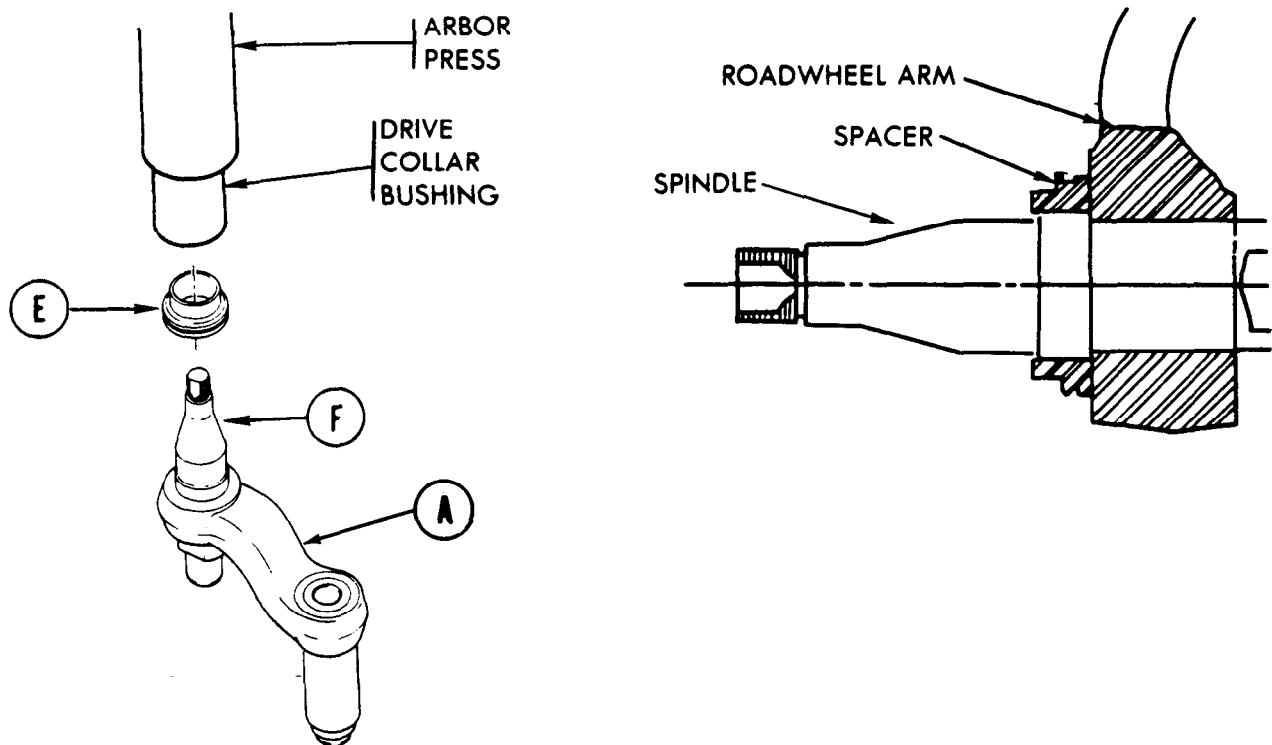

11. Install roadwheel arm (TM 5-5420-226-34).

End of Task

TA108076

COMPENSATING IDLER ARM ASSEMBLY REPAIR (LEFT AND RIGHT) (Sheet 1 of 5)

PROCEDURE INDEX

PROCEDURE	PAGE
Disassembly	9-24
Assembly	9-27

TOOLS: Hammer
 Chisel
 Arbor press
 Drive collar bushing 4 in. inside dia. 8 in. lg.
 Drive collar bushing 4-9/16 in. inside dia. 10 in. lg.
 Welding outfit

SUPPLIES: Crocus cloth (Item 4, Appendix B)

PERSONNEL: Two

REFERENCE: TM 5-5420-226-20

PRELIMINARY PROCEDURE: Remove compensating idler arm (TM 5-5420-226-20)

DISASSEMBLY:

NOTE

Compensating idler arm has two spindles. One spindle is tapered and is referred to as the lower spindle. The other spindle is not tapered and is referred to as the upper spindle.

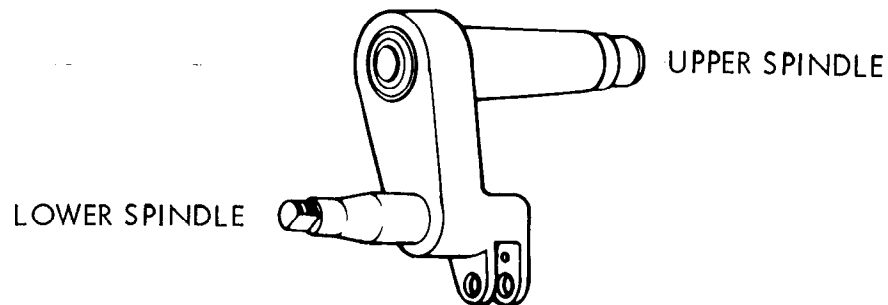

Go on to Sheet 2

TA108040

COMPENSATING IDLER ARM ASSEMBLY REPAIR (LEFT AND RIGHT) (Sheet 2 of 5)

1. Using two persons, place compensating idler arm assembly on work bench.
2. Using welding outfit as a heat source, apply heat to spacer (A). Using hammer and chisel, drive spacer (A) off spindle (B) of compensating idler arm (C). Throw spacer (A) away.
3. Examine bearing surface of spindle (B) for any cuts or marks made during removal of spacer (A).
4. Using crocus cloth (Item 4, Appendix B), smooth cuts or marks made on spindle (B) during removal.

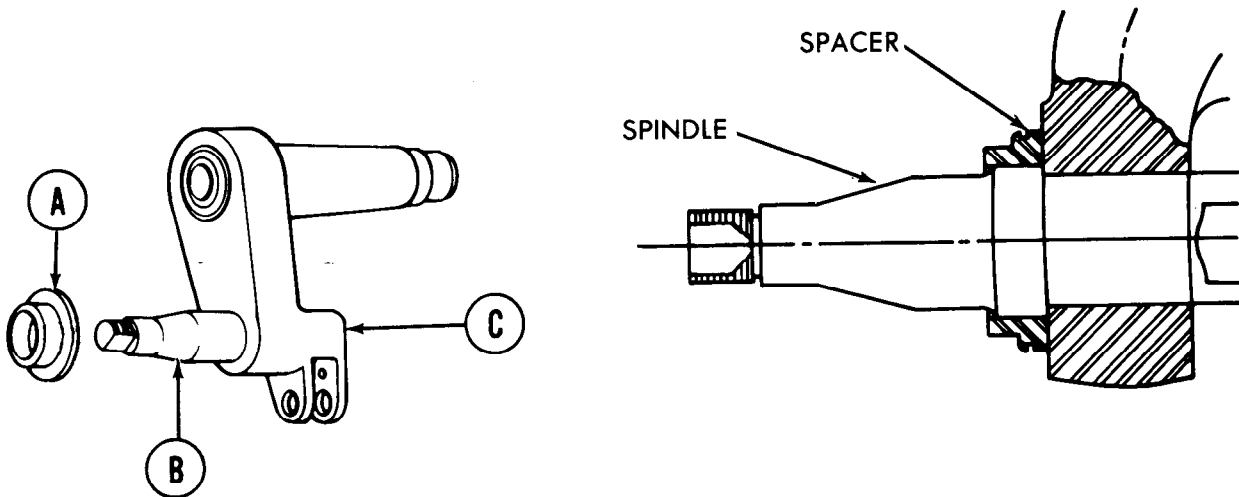

Go on to Sheet 3

TA108041

COMPENSATING IDLER ARM ASSEMBLY REPAIR (LEFT AND RIGHT) (Sheet 3 of 5)

5. Using welding outfit as a heat source, apply heat to bearing (D). Using hammer and chisel, drive bearing (D) off spindle (E). Throw bearing (D) away.

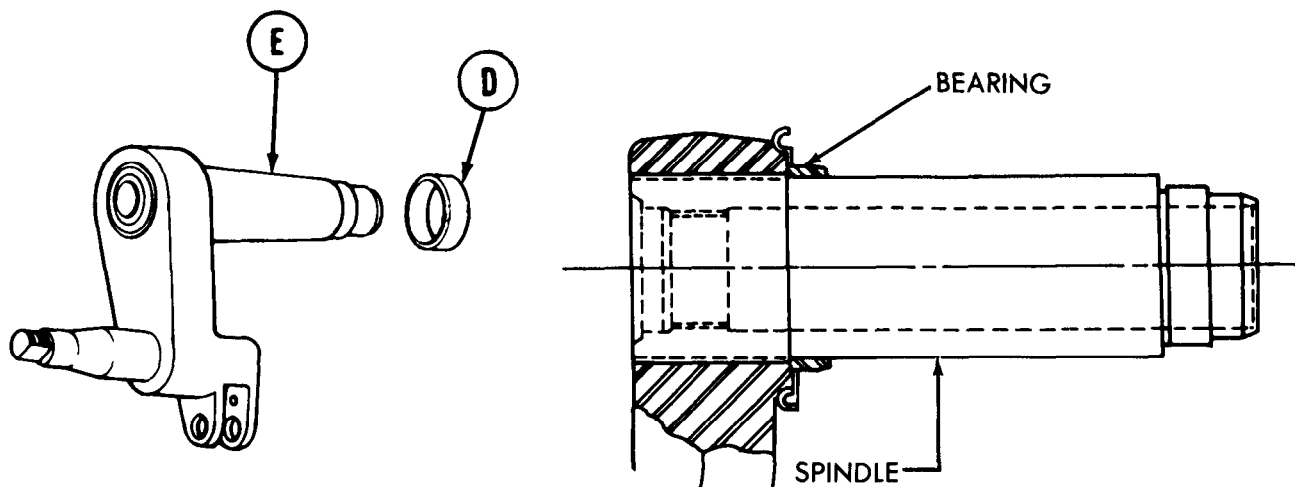

6. Examine bearing surface of spindle (E) for any cuts or marks made during removal of bearing (D).
7. Using crocus cloth (Item 4, Appendix B), smooth cuts or marks made on spindle (E) during removal.

COMPENSATING IDLER ARM ASSEMBLY REPAIR (LEFT AND RIGHT) (Sheet 4 of 5)

ASSEMBLY:

1. Using two persons, position compensating idler arm (A) on arbor press.

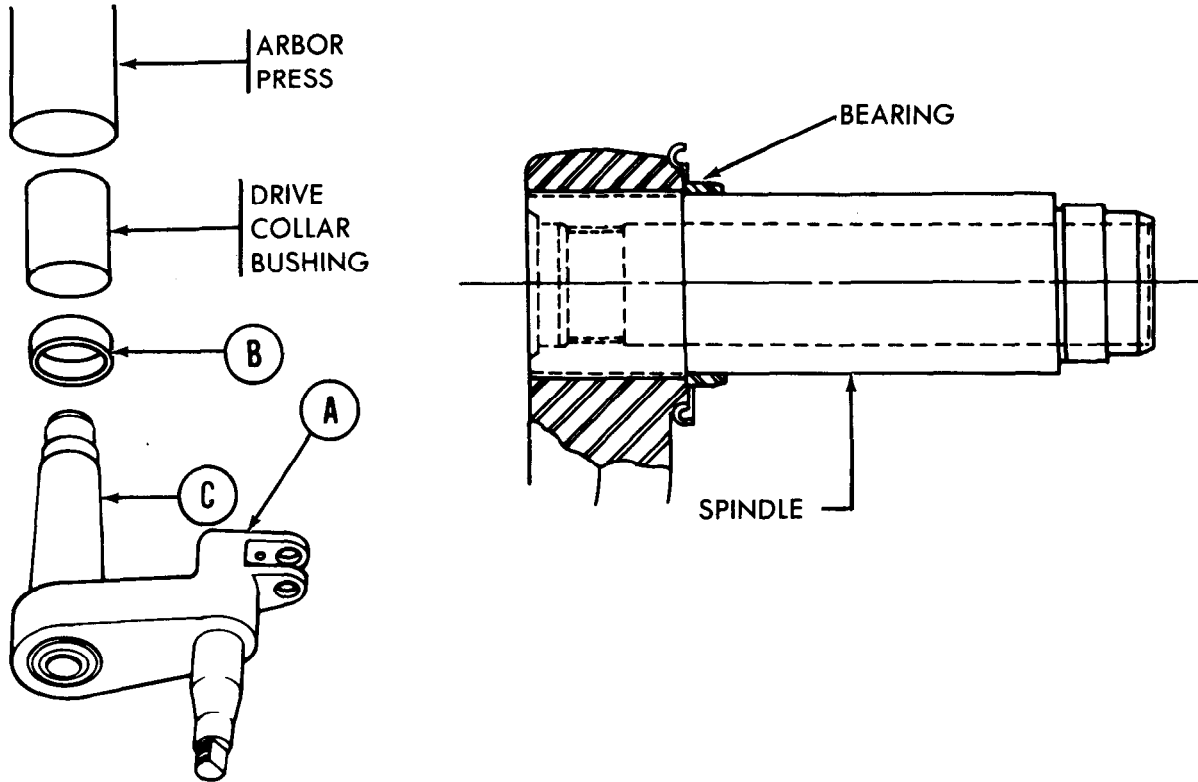

2. Position bearing (B) over idler arm upper spindle (C).
3. Position 4-9/16 inch inside diameter drive collar bushing over spindle (C) onto bearing (B) and, using arbor press, drive bearing (B) onto spindle (C) of idler arm (A).

NOTE

Seat bearing firmly all the way to the bottom of the spindle.

Go on to Sheet 5

TA108043

COMPENSATING IDLER ARM ASSEMBLY REPAIR (LEFT AND RIGHT) (Sheet 5 of 5)

4. Using two persons, reposition idler arm on arbor press.
5. Position spacer (F) over idler arm spindle (G).

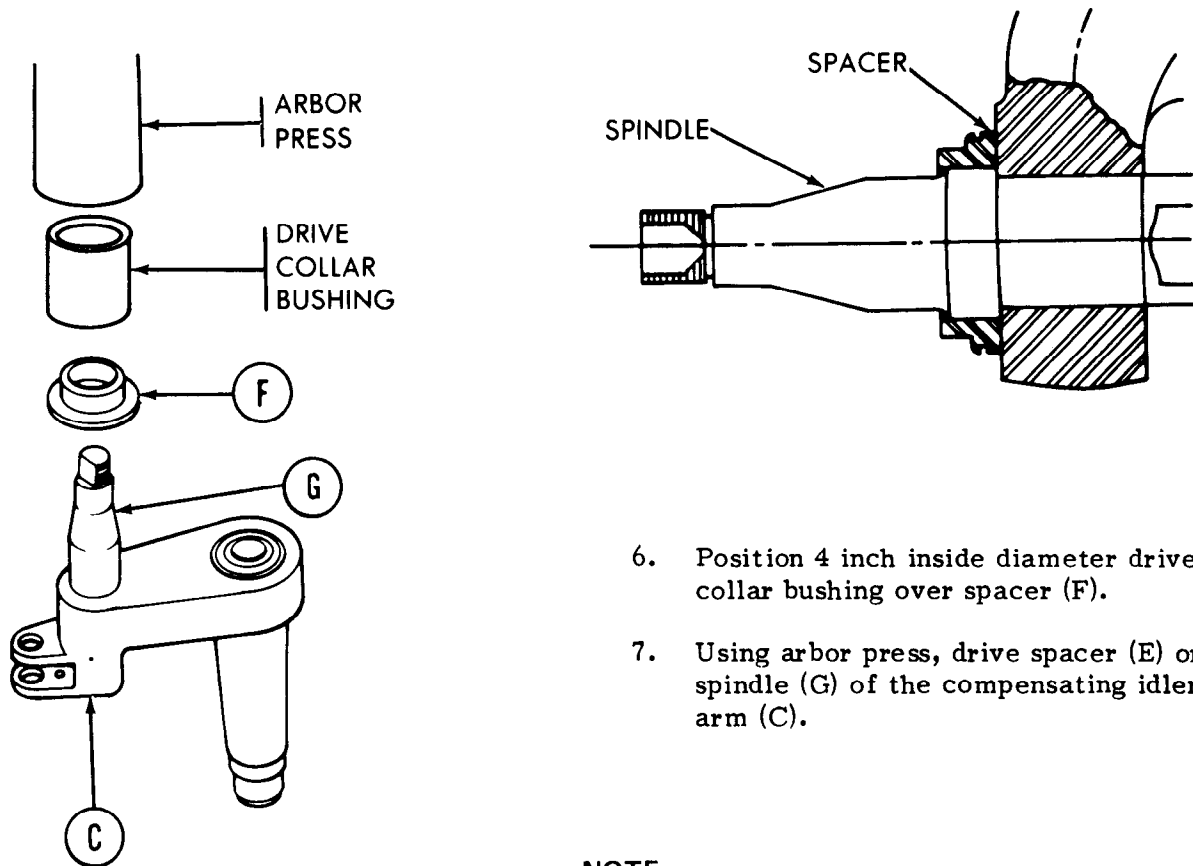

6. Position 4 inch inside diameter drive collar bushing over spacer (F).
7. Using arbor press, drive spacer (E) onto spindle (G) of the compensating idler arm (C).

NOTE

Seat spacer firmly all the way down to the bottom of the spindle.

8. Install compensating idler arm (TM 5-5420-226-20).

End of Task

CHAPTER 10
STEERING SYSTEM MAINTENANCE
INDEX

Procedure	Page
Steering Control Mount Assembly Repair	10-2
Steering Control Sleeve Assembly Replacement	10-3
Steering Shaft Assembly Repair and Replacement	10-7
Steering Control Rod Replacement	10-10
Support Steering Control Shield Replacement	10-12
Rear Steering Control Rod Replacement	10-14
Front Steering Link Assembly Replacement	10-17

STEERING CONTROL MOUNT ASSEMBLY REPAIR (Sheet 1 of 1)

TOOLS: Arbor press.

SUPPLIES: Brass bar stock 1-15/16 in. diameter

REFERENCE: TM 5-5420-226-20

PRELIMINARY PROCEDURE: Remove steering control mount assembly (TM 5-5420-226-20)

INSPECTION AND REPAIR:

1. Inspect mount (A) and bearings (B) for cuts, nicks, deterioration, or wear.
2. Replace bearings and mount as required.

NOTE

When bearings (B) need to be replaced, go to step 3.

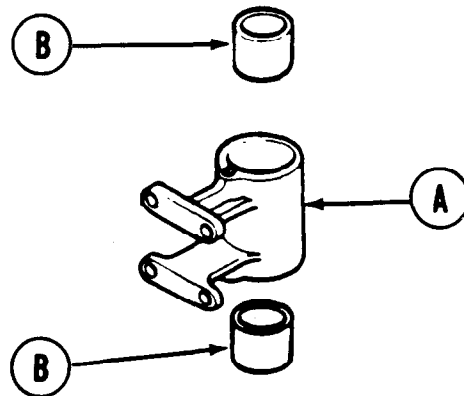

3. Using press and brass bar, remove two bearings (B) from mount (A).
4. Using press and brass bar, install two bearings (B) into mount (A).
5. Install steering control mount assembly (TM 5-5420-226-20).

End of Task

TA108551

STEERING CONTROL SLEEVE ASSEMBLY REPLACEMENT AND REPAIR (Sheet 1 of 4)

PROCEDURE INDEX

PROCEDURE	PAGE
Removal	10-3
Disassembly	10-4
Assembly	10-5
Installation	10-6

TOOLS: 6 in. rule
 5/16 in. combination box and open end wrench
 7/16 in. combination box and open end wrench
 9/16 in. combination box and open end wrench (2 required)
 Hammer
 Vise

Torque wrench with 3/8 in. drive (0-200 lb-in) (0-23 N·m)
 7/16 in. crowfoot wrench with 3/8 in. drive
 9/16 in. crowfoot wrench with 3/8 in. drive
 9/16 in. socket with 3/8 in. drive
 1/8 in. hex wrench, six point (allen)
 Ratchet with 3/8 in. drive

FABRICATED TOOL: Bearing installation and removal tool (Figure D-2, Appendix D)

SUPPLIES: Seal (7748748) (2 required)

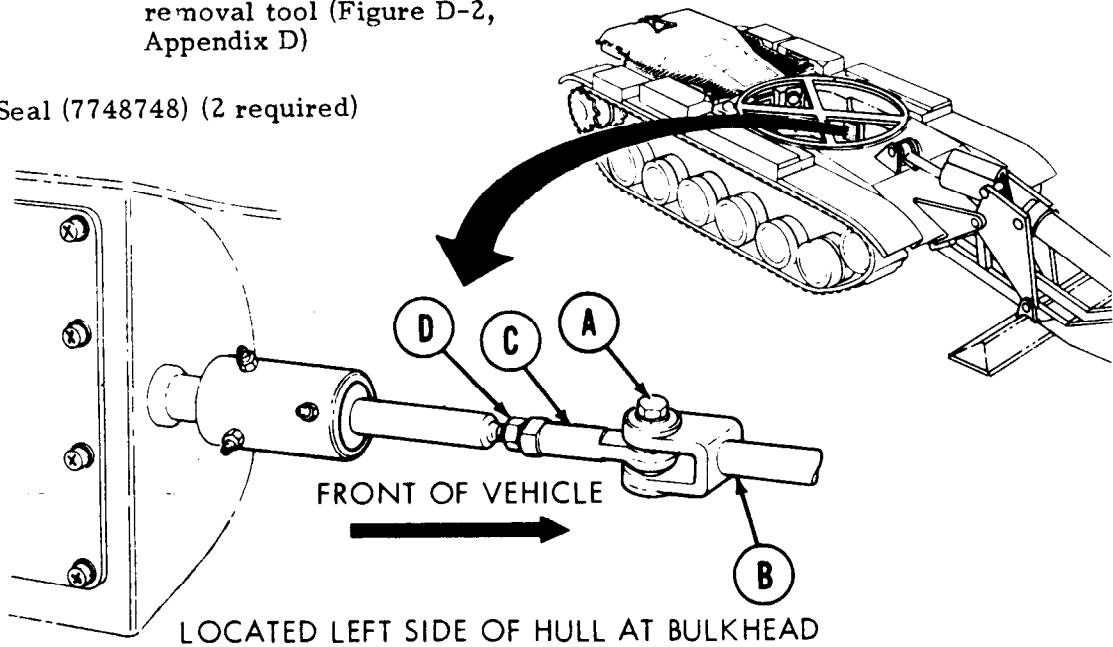

REMOVAL:

- Using 9/16 inch wrench, remove screw (A) securing front intermediate rod (B) to bulkhead shaft rod end (C).
- Using 9/16 inch wrench to hold nut (D), use 9/16 inch wrench to remove rod end (C).

Go on to Sheet 2

TA108554

STEERING CONTROL SLEEVE ASSEMBLY REPLACEMENT AND REPAIR (Sheet 2 of 4)

3. Using 9/16 inch wrench, remove nut (D) from bulkhead shaft (E).
4. Using 7/16 inch wrench, remove two jamnuts (F).
5. Using 1/8 inch hex wrench, remove two setscrews (G).
6. Slide sleeve assembly (H) toward front of vehicle and off shaft (E).

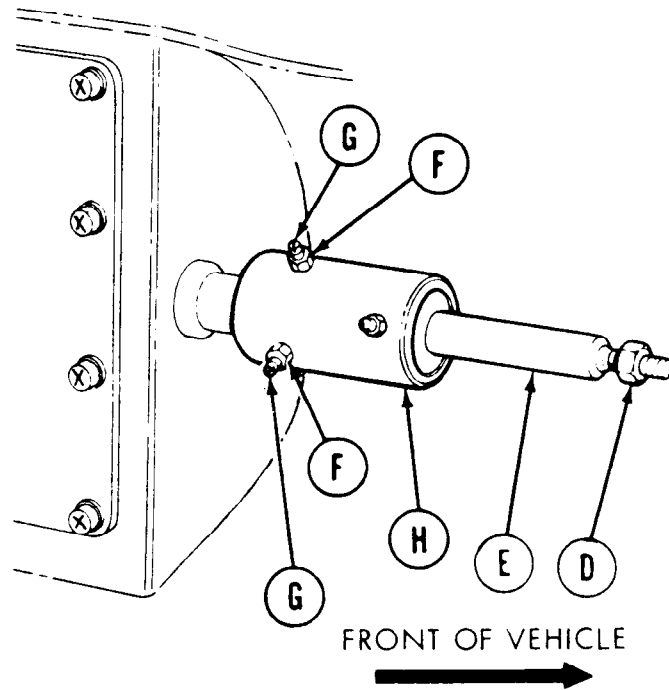

DISASSEMBLY:

1. Using 5/16 inch wrench, remove grease fitting (A) from sleeve (B).
2. Position sleeve (B) in vise. Using hammer and bearing installation and removal tool, remove two seals (C) and bearing (D) from sleeve (B). Throw seals (C) and bearing (D) away.

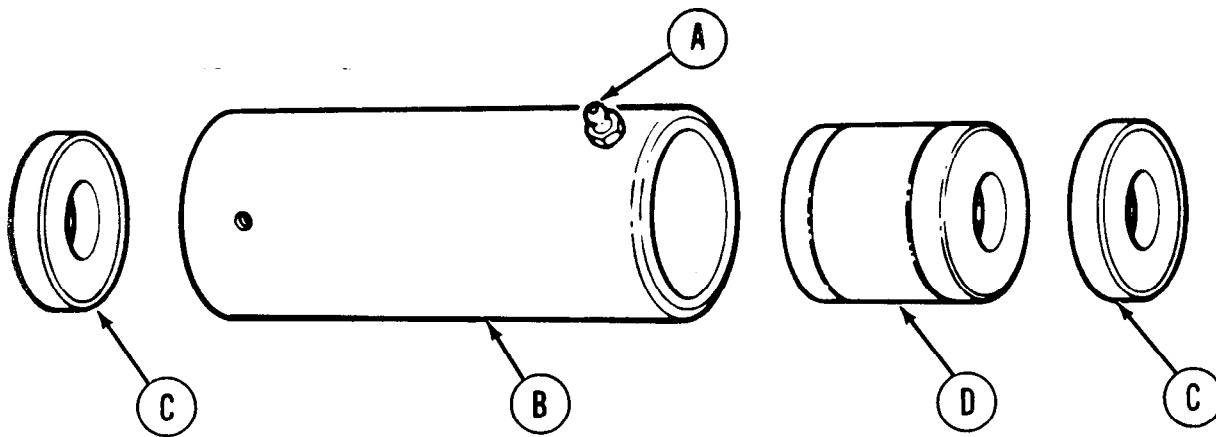

Go on to Sheet 3

TA108555

STEERING CONTROL SLEEVE ASSEMBLY REPLACEMENT AND REPAIR (Sheet 3 of 4)

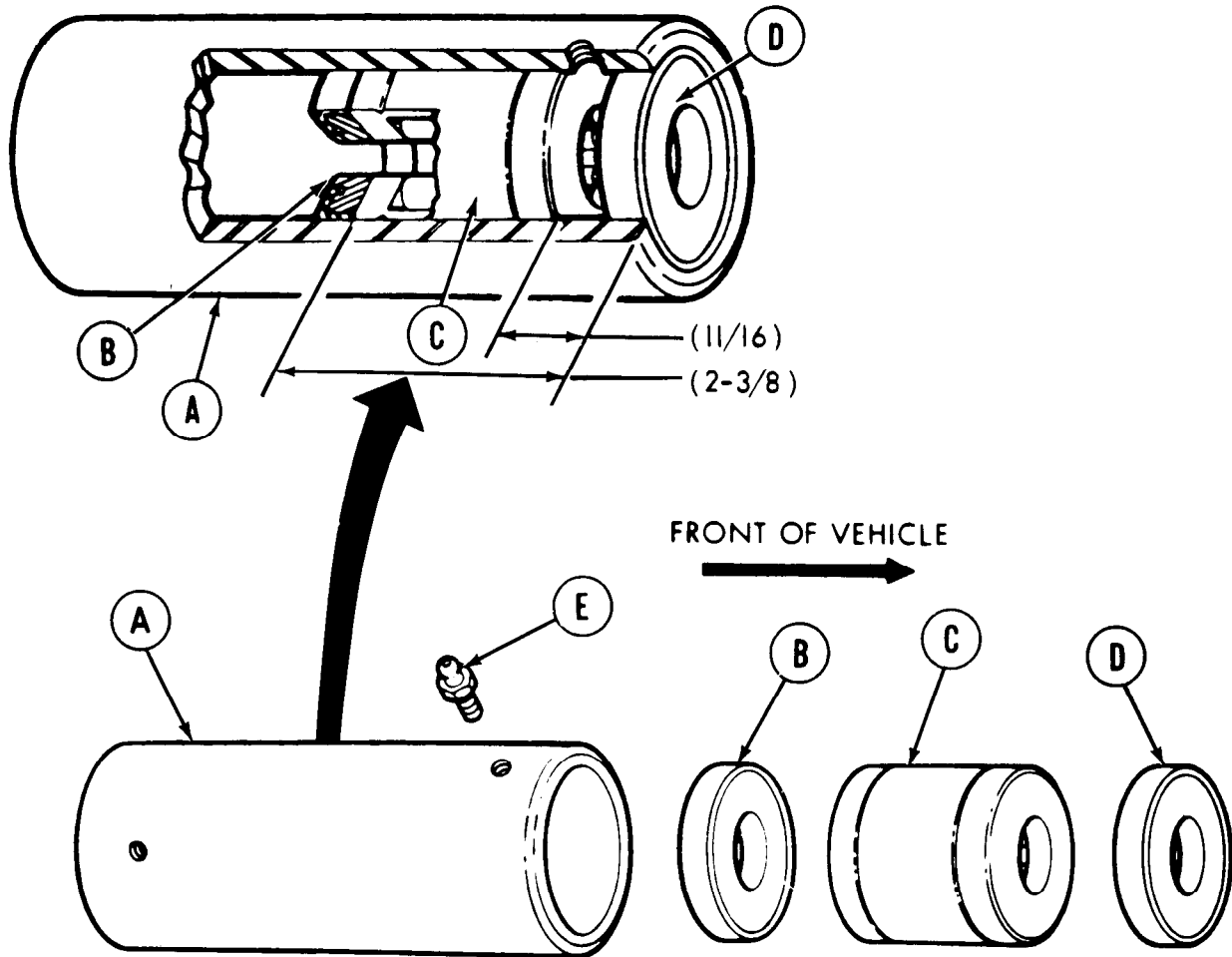

ASSEMBLY:

1. Position sleeve (A) in vise. Using hammer and bearing installation and removal tool, install new seal (B) into sleeve (A) with lip facing outward. Make sure the front part of seal (B) measures $2-3/8$ inches from the front of sleeve (A).
2. Using hammer and bearing installation and removal tool, install new bearings (C) into sleeve (A). Make sure bearing fits snug against seal (B) and is $11/16$ inch from the front of sleeve (A).
3. Using hammer and bearing installation and removal tool, install new seal (D) into sleeve (A) with lip facing outward.
4. Using $5/16$ inch open end wrench, install new grease fitting (E) into sleeve (A).

Go on to Sheet 4

TA108556

STEERING CONTROL SLEEVE ASSEMBLY REPLACEMENT AND REPAIR (Sheet 4 of 4)

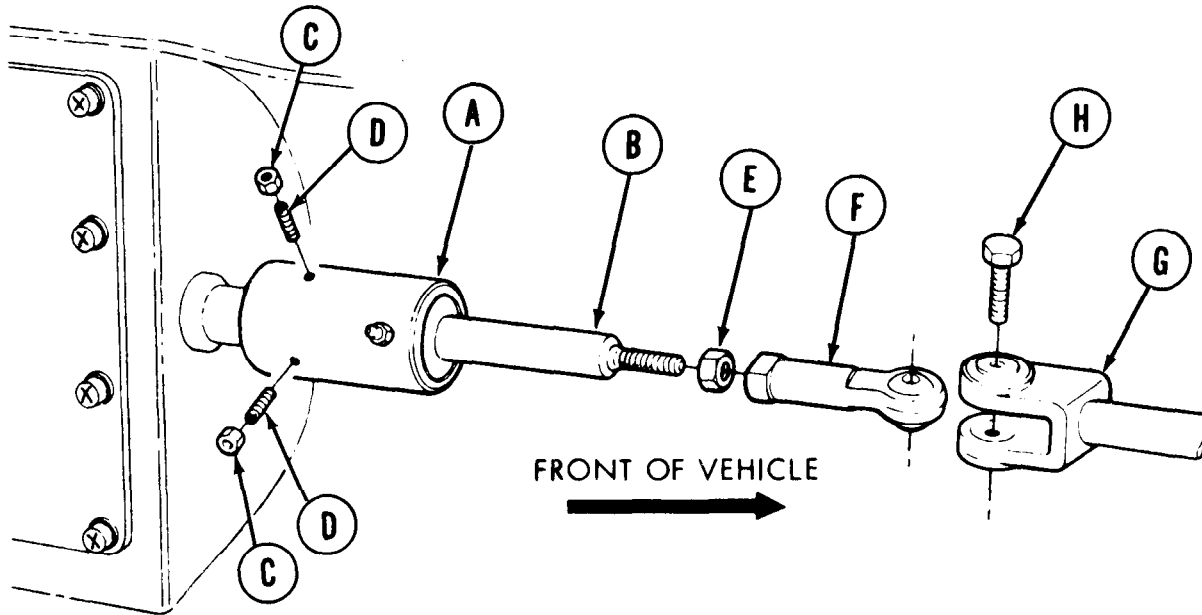

INSTALLATION:

1. Slide sleeve assembly (A) over shaft assembly (B) as far as it will go.
2. Using 7/16 inch wrench to hold two jamnuts (C), use allen wrench to install two setscrews (D) through jamnuts (C) into sleeve (A) until screws bottom out on hull connector. Hold screw and, using torque wrench and 7/16 inch crowfoot wrench, tighten nut (C) to 90 lb-in (10 N·m).
3. Using 9/16 inch wrench, install nut (E) onto shaft (B).
4. Using 9/16 inch wrench to hold nut (E), use 9/16 inch wrench to install rod end (F) into shaft (B). Using torque wrench and 9/16 inch crowfoot, tighten rod end (F) to 192 lb-in (21 N·m).
5. Position rod end (F) into clevis end (G) and, using 9/16 inch wrench, install screw (H) through rod end (F) and clevis end (G). Using torque wrench and 9/16 inch socket, tighten screw to 192 lb-in (21 N·m).
6. Adjust steering control (TM 5-5420-226-20).

End of Task

TA108557

STEERING SHAFT ASSEMBLY REPAIR AND REPLACEMENT (Sheet 1 of 3)

TOOLS: Hammer
 1/8 in. drive punch
 5/8 in. combination box and open end wrench (2 required)
 Vise

SUPPLIES: Pins (MS9390-440) (2 required)

REFERENCE: TM 5-5420-226-20

PRELIMINARY PROCEDURES: Remove steering control sleeve (page 10-5)
 Disconnect rear steering control rod end (page 10-16, steps 1-4)
 Remove left fuel tank (page 4-24)

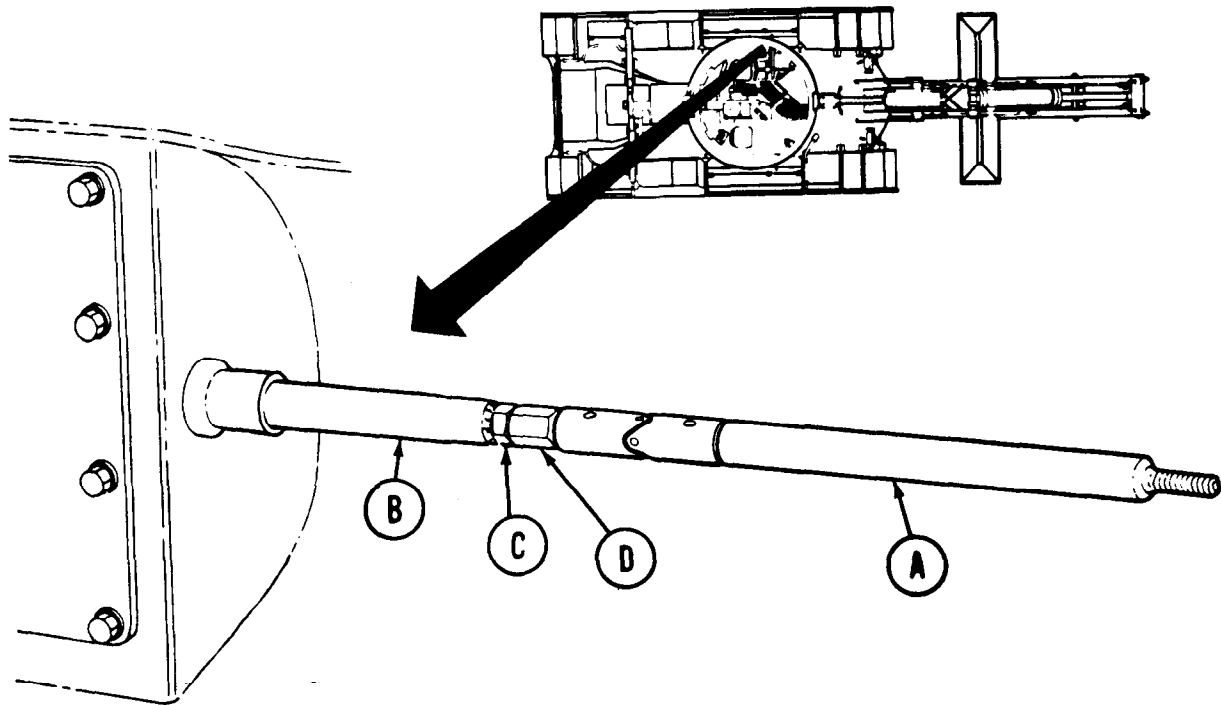
**REMOVAL:**

1. Using hands, pull shaft (A) forward until shaft (B) is exposed at bulkhead.
2. Using 5/8 inch wrench to hold jamnut (C), use 5/8 inch wrench on plug (D) and remove shaft assembly (A).

Go on to Sheet 2

TA108558

STEERING SHAFT ASSEMBLY REPAIR AND REPLACEMENT (Sheet 2 of 3)

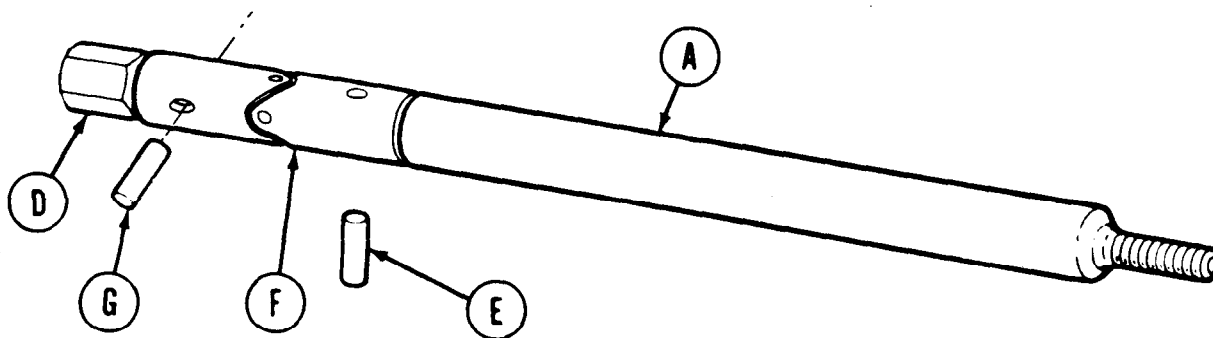

3. Position shaft (A) in vise and using hammer and punch, remove pin (E) from universal joint (F). Throw pin (E) away.
4. Using hammer and punch, remove pin (G) from universal joint (F). Throw pin (G) away.
5. Remove plug (D) from universal joint (F).
6. Remove shaft (A) from universal joint (F).
7. Inspect shaft (A), universal joint (F), and plug (D) for looseness and wear. Replace defective parts.

INSTALLATION:

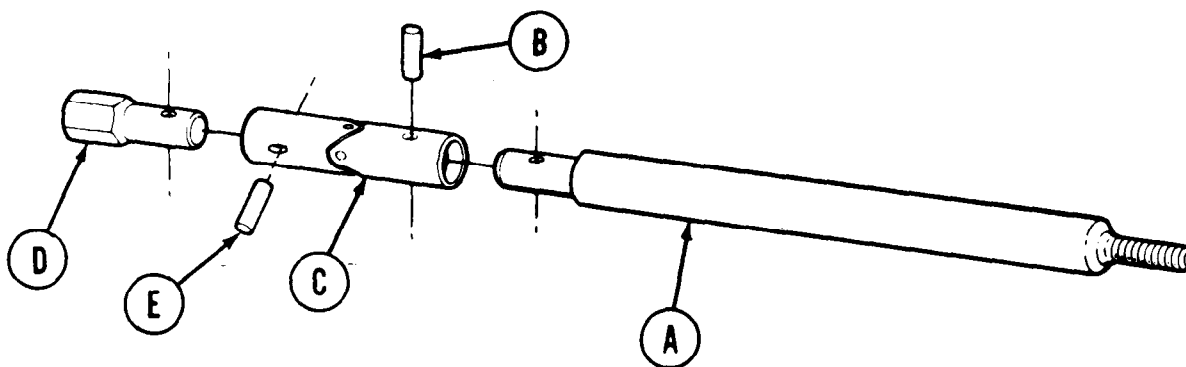

1. Position shaft (A) in vise and, using hammer and punch, install new pin (B) into universal joint (C) and shaft (A).
2. Position plug (D) into universal joint (C) and using hammer and punch, install pin (E) into universal joint (C) and plug (D).

Go on to Sheet 3

TA108559

STEERING SHAFT ASSEMBLY REPAIR AND REPLACEMENT (Sheet 3 of 3)

3. Remove shaft assembly (A) from vise and take it to crew compartment.

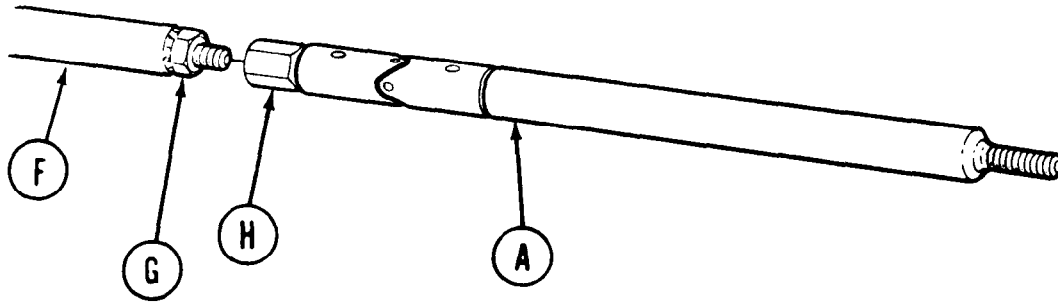

4. Position shaft assembly (A) onto shaft (F). Using 5/8 inch wrench to hold jamnut (G), use 5/8 inch wrench on plug (H) and tighten plug (H) against jamnut (G).
5. Install steering control sleeve (page 10-7).
6. Connect rear steering control rod end (pages 10-17 and 10-18, steps 5-11).
7. Adjust steering linkage (TM 5-5420-226-20).
8. Install left fuel tank (page 4-32).

End of Task

TA108560

STEERING CONTROL ROD REPLACEMENT (Sheet 1 of 2)

TOOLS: 5/8 in. combination box and open end wrench (2 required)

REFERENCES: TM 5-5420-226-20

PRELIMINARY PROCEDURES: Remove left fuel tank (page 4-25)
Remove outer riser link shield at rear of powerplant (TM 5-5420-226-20)
Remove support straps (page 10-14)
Remove rear steering linkage shield and rear control rod (page 10-14)

REMOVAL:

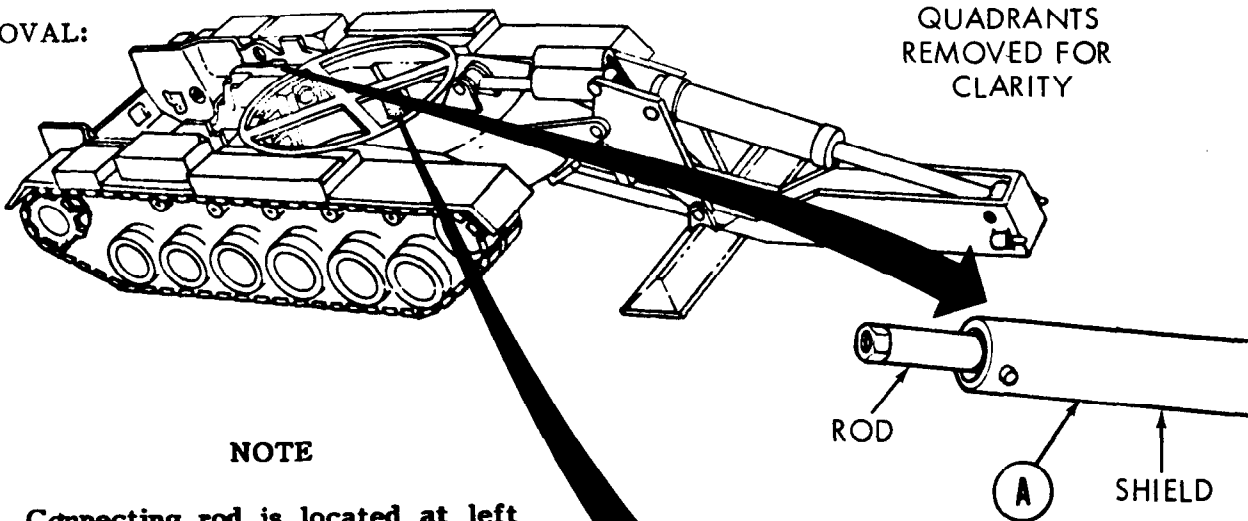

NOTE

Connecting rod is located at left side of powerplant compartment.

1. Pull shield (A) to rear of vehicle and remove.

NOTE

Go to crew compartment and locate left access cover.

2. Using one 5/8 inch wrench to hold plug (B) and other 5/8 inch wrench to hold end of rod (C), remove rod (C).

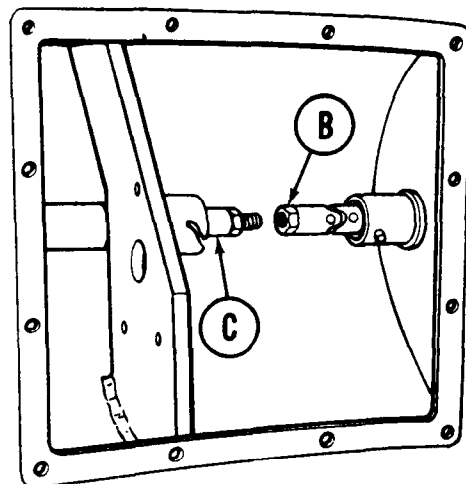

Go on to Sheet 2

TA108561

STEERING CONTROL ROD REPLACEMENT (Sheet 2 of 2)**INSPECTION:**

1. Inspect shield for cracks, dents, or warpage.
2. Inspect steering control rod for bends, breaks, or stripped threads.

INSTALLATION:**NOTE**

Make sure end plug (A) is tight and secure.

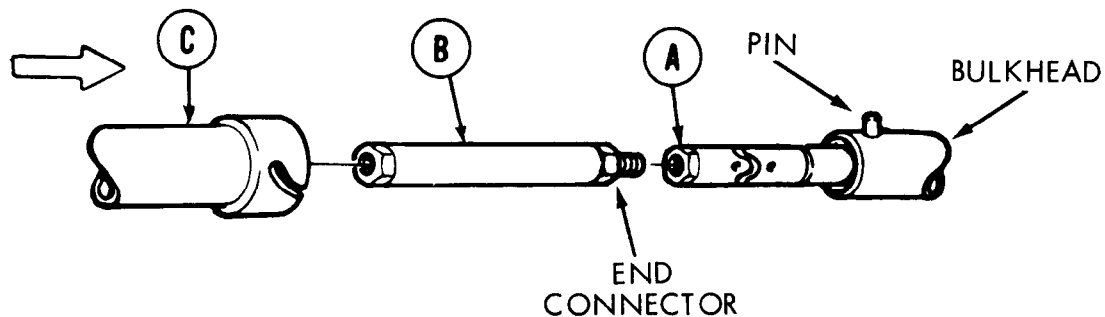

1. Using both hands, screw connector rod (B) into end plug (A) near bulkhead.
2. Using 5/8 inch wrench at end connector of rod (B) and another 5/8 inch wrench at end plug (A), tighten rod (B) into end plug (A).
3. Slide shield (C) over rod (B) so pin near bulkhead fits into slot of shield.
4. Install support strap (page 10-15).
5. Install rear connector rod and its cover shield (page 10-15).
6. Install outer riser link shield at rear of powerplant compartment (TM 5-5420-226-20).
7. Install left fuel tank (page 4-32).

End of Task

TA108562

SUPPORT STEERING CONTROL SHIELD REPLACEMENT (Sheet 1 of 2)

TOOLS: Torque wrench with 3/8 in. drive
(0-200 lb-in) (0-23 N·m)
1/2 in. combination box and
open end wrench

Ratchet with 3/8 in. drive
5/8 in. combination box and
open end wrench (2 required)
1/2 in. socket with 3/8 in. drive

REFERENCE: TM 5-5420-226-20

PRELIMINARY PROCEDURES: Remove left fuel tank (page 4-25)
Disconnect control rod at rear clevis (page 10-16, steps
1-4)

REMOVAL:

1. Using 1/2 inch socket and ratchet, remove four screws (A) and washers (B). Remove straps (C).
2. Slide shield (D) back approximately two inches toward rear of vehicle.
3. Using two 5/8 inch wrenches, disconnect rear control rod (E).
4. Remove shield (D) and control rod (E).
5. Remove front shield (F) from vehicle.
6. Using 1/2 inch wrench to hold screw (G), use 1/2 inch socket and ratchet to remove four nuts (H) and washers (J) from screws (G).
7. Remove four screws (G) and two supports (K) from plates (L).

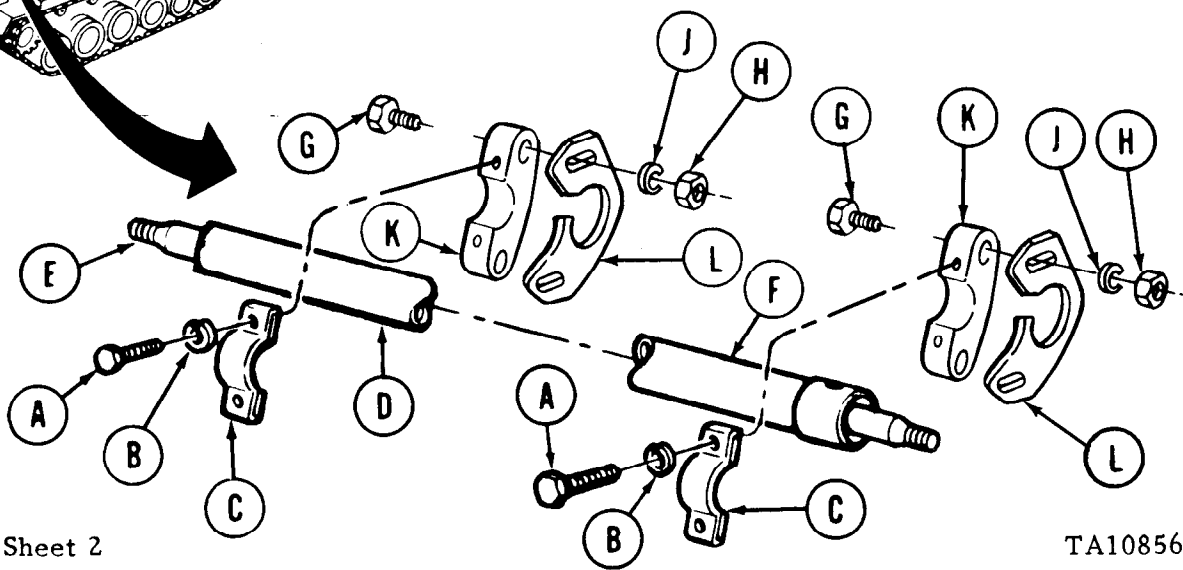
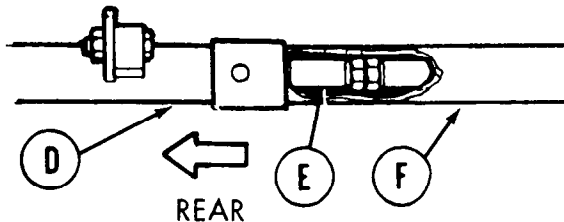
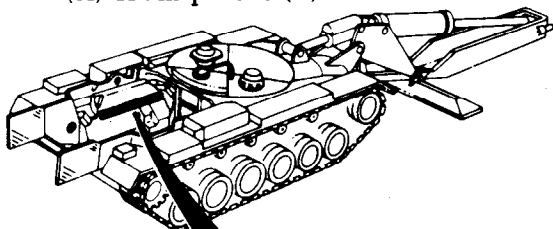

Go on to Sheet 2

TA108563

SUPPORT STEERING CONTROL SHIELD REPLACEMENT (Sheet 2 of 2)

INSTALLATION:

1. Position support (A) onto plate (B) and install four screws (C) through support (A) and plate (B).

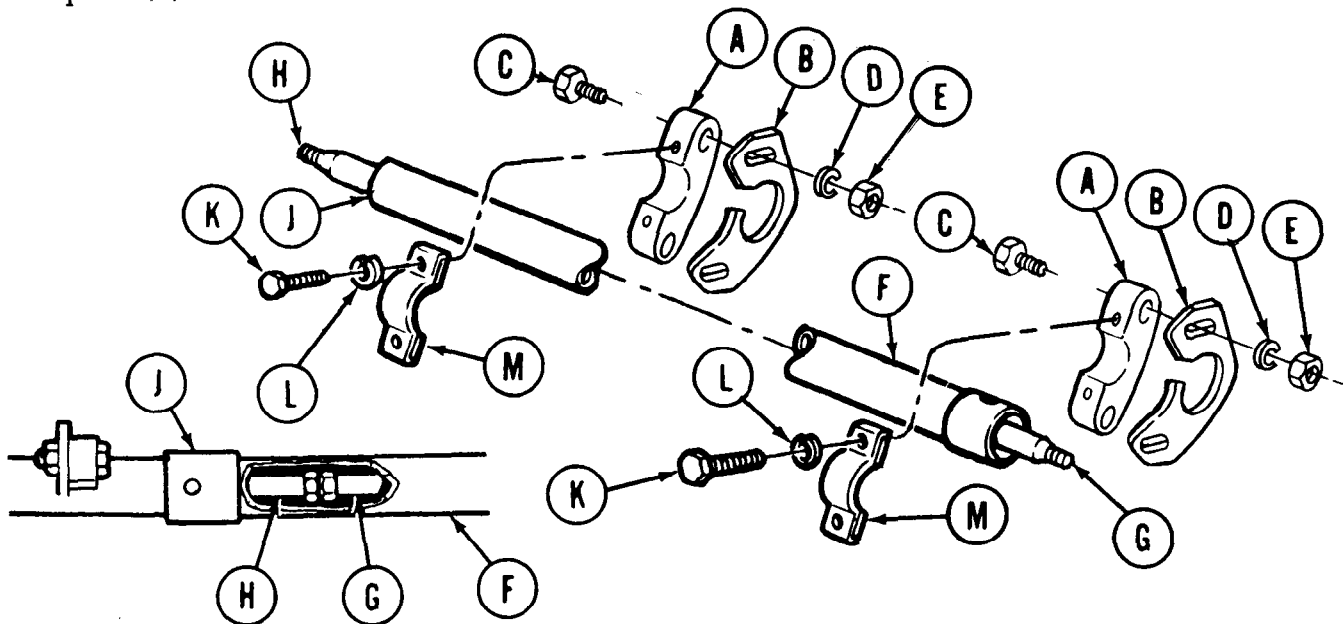

2. Position four washers (D) and nuts (E) onto four screws (C).
3. Using 1/2 inch wrench to hold screws (C), use torque wrench and 1/2 inch socket to tighten four nuts (E) to 114 lb-in (13 N·m).
4. Place front shield (F) over rod (G).
5. Place rear rod (H) and shield (J) in position. Using two 5/8 inch wrenches, connect front rod (G) and rear rod (H).
6. Move front shield (F) and rear shield (J) toward front of vehicle until secure.
7. Position four screws (K) and four washers (L) through straps (M) into supports (A). Use torque wrench and 1/2 inch socket to tighten four screws (K) to 114 lb-in (13 N·m).
8. Connect rear control rod to clevis (pages 10-17 and 10-18, steps 5-11).
9. Install left fuel tank (page 4-32).

End of Task

TA108564

REAR STEERING CONTROL ROD REPLACEMENT (Sheet 1 of 3)

TOOLS: 9/16 in. combination box and open end wrench
 5/8 in. combination box and open end wrench (2 required)
 9/16 in. crowfoot wrench with 3/8 in. drive
 Troque wrench with 3/8 in. drive (0-200 lb-in) (0-23 N.m)

REFERENCE: TM 5-5420-226-20

PRELIMINARY PROCEDURES: Remove left fuel tank (page 4-25)
 Remove support straps (page 10-14)
 Remove outer riser link shield at rear of vehicle (TM 5-5420-226-20)

REMOVAL:

- Using 9/16 inch wrench, loosen jamnut (A).

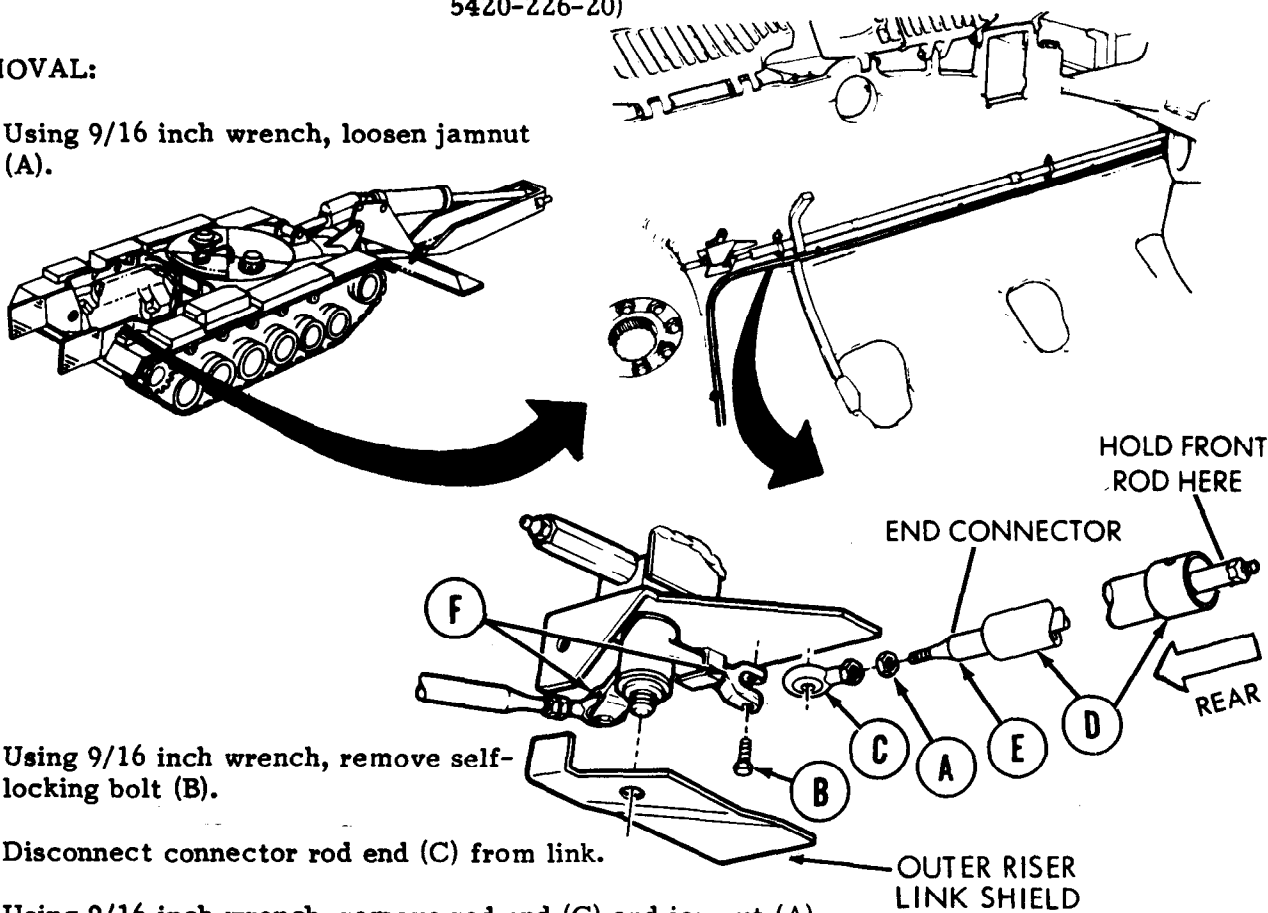

- Using 9/16 inch wrench, remove self-locking bolt (B).
- Disconnect connector rod end (C) from link.
- Using 9/16 inch wrench, remove rod end (C) and jamnut (A).
- Pull shield (D) to rear. Pull it off rod (E) toward rear of vehicle.
- Using two 5/8 inch wrenches, one to hold front rod while loosening connecting rod at end connector, remove rear steering control rod (E).
- If necessary, remove connecting link assembly (F) (TM 5-5420-226-20).

Go on to Sheet 2

TA108565

REAR STEERING CONTROL ROD REPLACEMENT (Sheet 2 of 3)**INSPECTION:**

1. Inspect rod for cracks and bends.
2. Inspect threads for stripped areas.

INSTALLATION:

1. Using both hands, tighten rear steering control rod (A) onto front rod.

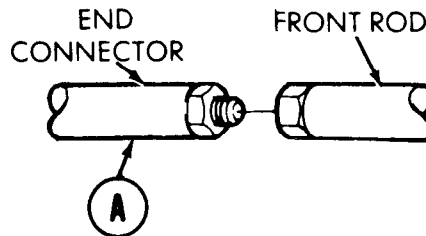

2. Using one 5/8 inch wrench to hold front rod and other 5/8 inch wrench on end connector of rear steering rod (A), tighten rod (A) in place.

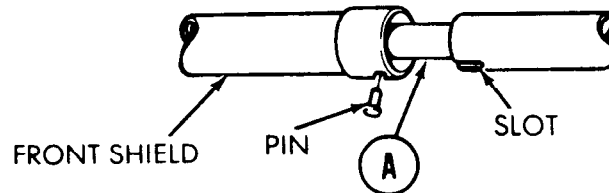

3. Slide shield (B) over rod (A).
4. Connect shield (B) by inserting rear shield pin into slot of shield (B) and pushing forward on shield (to lock in place).
5. Screw jamnut (C) onto threaded end of rod (A).
6. Screw rod end (D) into threaded end of rod (A).
7. If connecting link (E) was removed, install it (TM 5-5420-226-20).

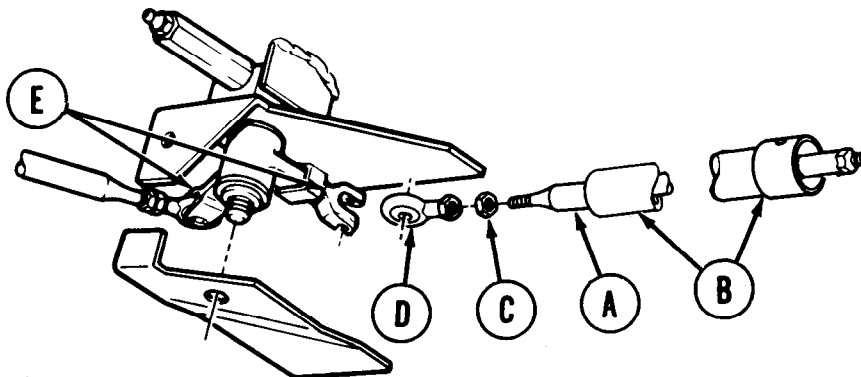

Go on to Sheet 3

TA108566

REAR STEERING CONTROL ROD REPLACEMENT (Sheet 3 of 3)

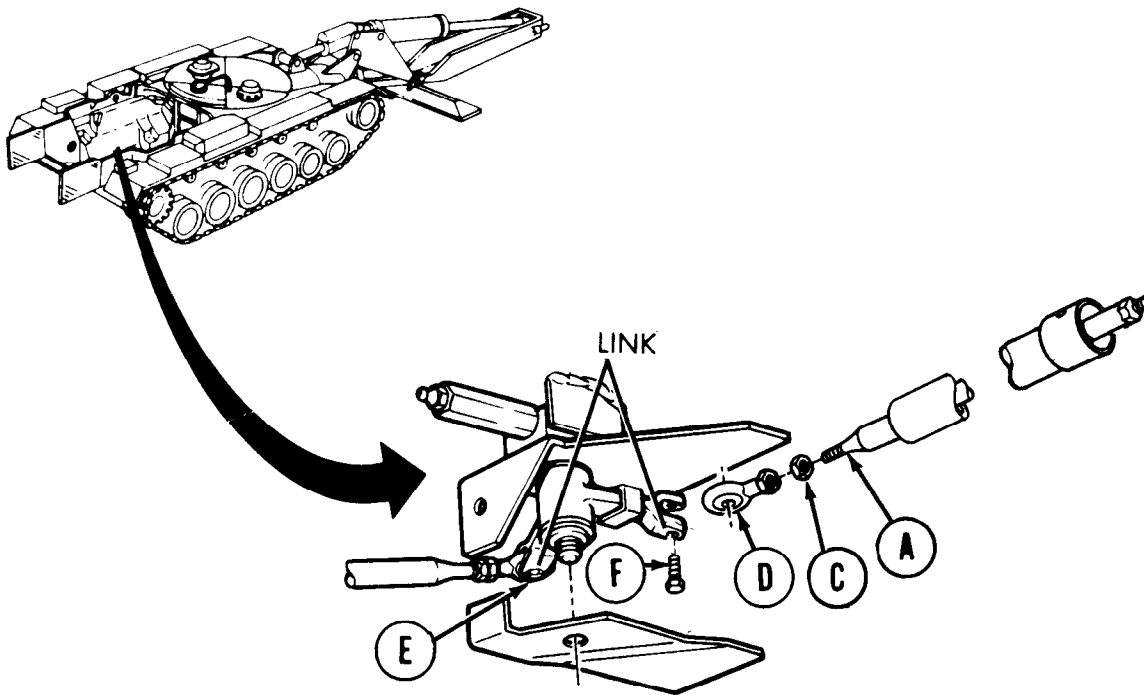

8. Adjust rod end (D) on rod (A) so rod end will align to link (E).
9. Screw bolt (F) into link (E) and rod end (D) connection.
10. Using 9/16 inch wrench, tighten bolt (F).
11. Using 9/16 inch wrench, tighten jamnut (C) up to rod end (D).
12. Install outer riser link shield at rear of vehicle (TM 5-5420-226-20).
13. Install support straps (page 10-15).
14. Install left fuel tank (page 4-32).

End of Task

TA108567

FRONT STEERING LINK ASSEMBLY REPLACEMENT (Sheet 1 of 3)

PROCEDURE INDEX

PROCEDURE	PAGE
Removal	10-17
Installation	10-19

TOOLS: 9/16 in. combination box and open end wrench
 Oxy-acetylene torch
 Grinder
 C-clamps
 Electric welder

REFERENCE: TM 5-5420-226-10
 TM 9-237

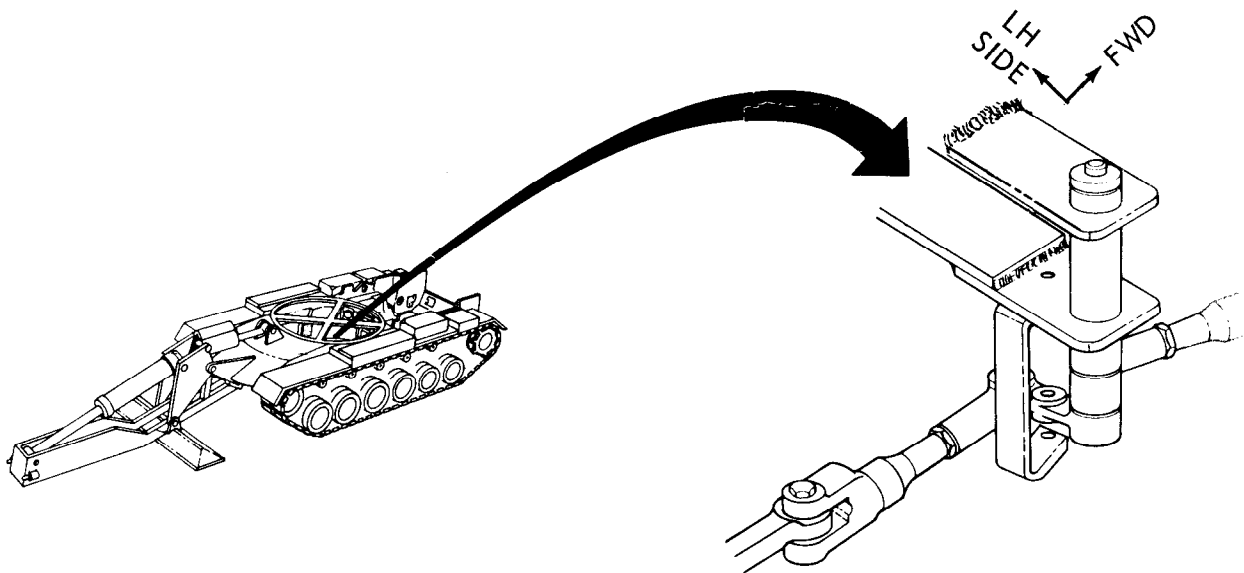

Go on to Sheet 2

TA108223

FRONT STEERING LINK ASSEMBLY REPLACEMENT (Sheet 2 of 3)

REMOVAL:

1. Using 9/16 inch wrench, remove bolt (A) from link (B).
2. Push rod end (C) aside.
3. Using 9/16 inch wrench, remove bolt (A) from link (D).
4. Push rod end (E) aside.
5. Using oxy-acetylene torch, remove link assembly (F) from supports which are welded to hull. (TM 9-237).

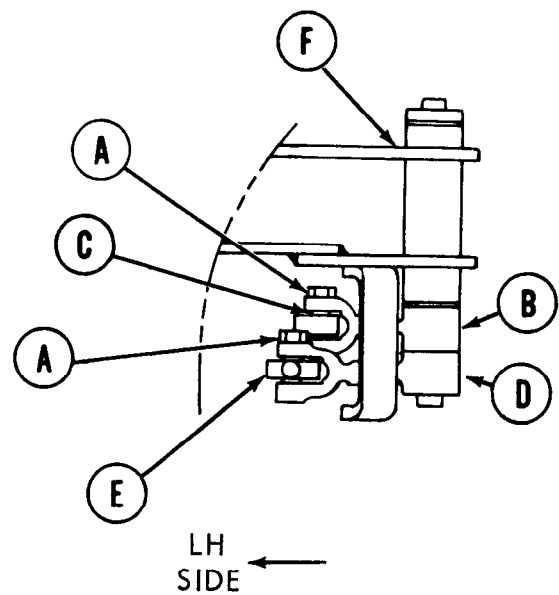

Go on to Sheet 3

TA108233

FRONT STEERING LINK ASSEMBLY REPLACEMENT (Sheet 3 of 3)**INSTALLATION:****NOTE**

Use grinder to clean up old welds so new assembly can be welded in place.

1. Using C-clamp (A), clamp new link assembly in place.
2. Using electric welder, weld new link assembly (B) in place (TM 9-237).
3. Aline rod end (C) in link (D).
4. Using 9/16 inch wrench, install bolt (E) in link (D).
5. Aline rod end (F) in link (G).
6. Using 9/16 inch wrench, install bolt (E) in link (G).
7. Test operation of link assembly (B) (TM 5-5420-226-10).

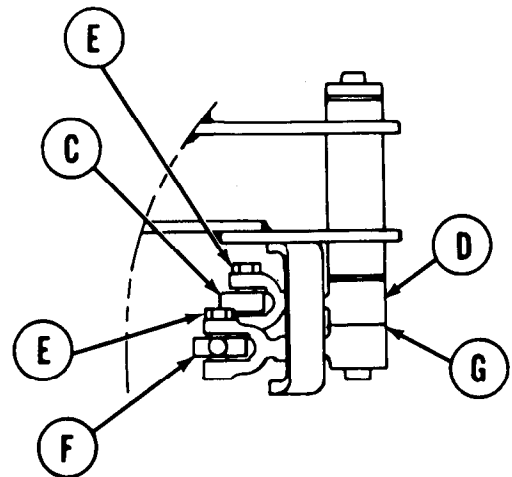
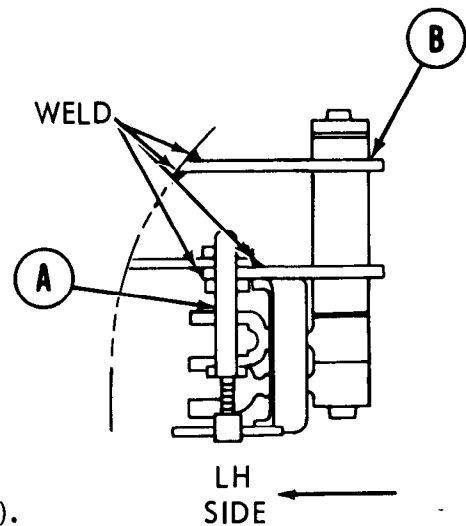

End of Task

TA108239

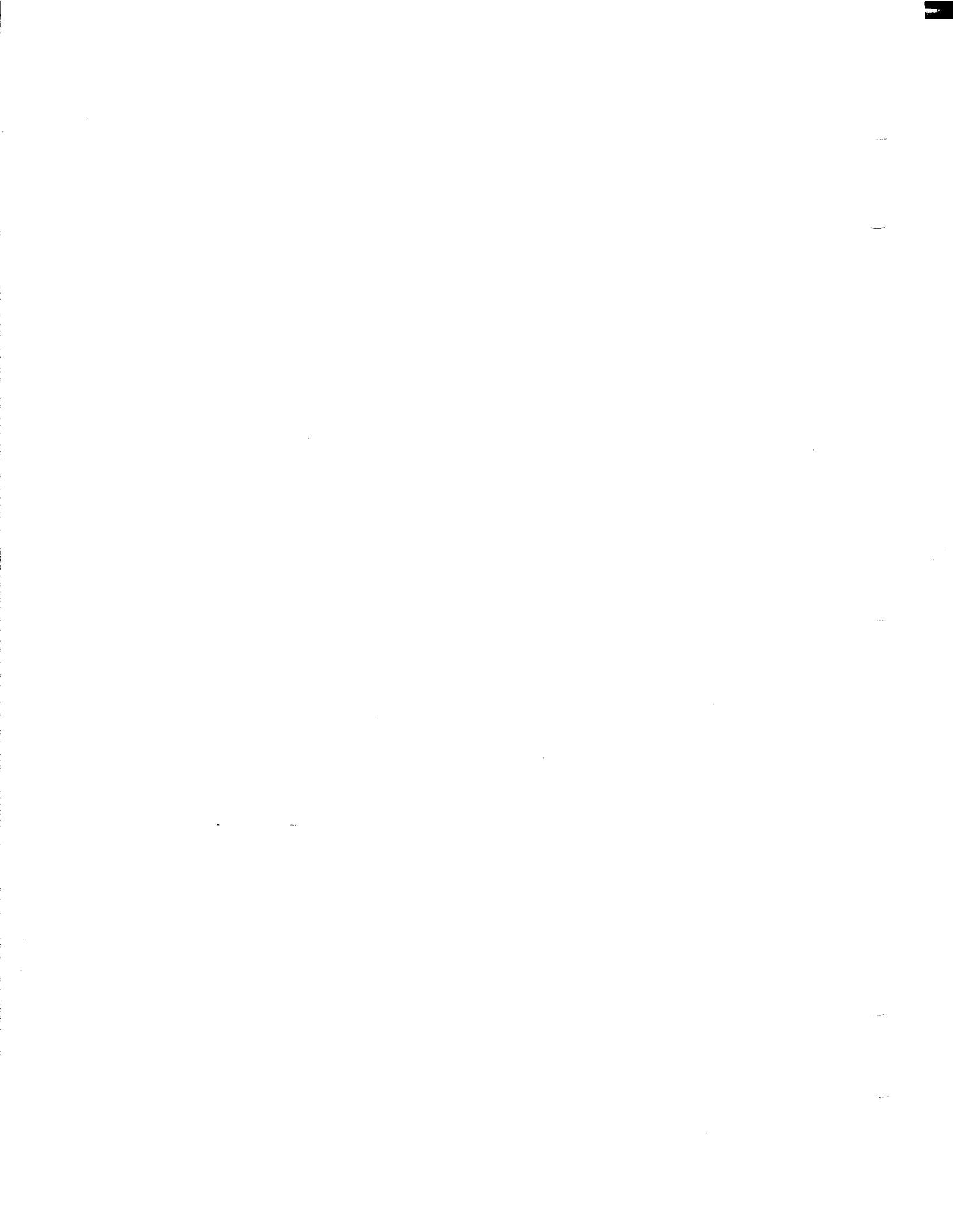

CHAPTER 10.1

SMOKE GRENADE LAUNCHER MAINTENANCE

GRENADE LAUNCHER POWER CONTROL BOX REPAIR (Sheet 1 of 7)

PROCEDURE	PROCEDURE INDEX	PAGE
Testing		10.1-2
Disassembly		10.1-4
Assembly		10.1-6

TOOLS: No. 3 cross-tip screwdriver
 Soldering iron
 Knife
 9/16" combination wrench
 Heat gun (NSN 4940-00-561-1002)

TEST EQUIPMENT: Multimeter
 24-28 vdc power source
 Power source leads (two)

SUPPLIES: Masking tape (Item 24, Appendix B)
 Solder (Item 23.1, Appendix B)
 Insulation sleeving (Item 15.1, Appendix B)
 Gasket 11655077
 Lockwasher MS35338-40 (4 required)
 Lockwasher MS35338-44 (4 required)
 Pencil (Item 28, Appendix B)
 Packing MS25196-1

REFERENCE: TM 5-5420-226-20

PRELIMINARY PROCEDURE: Remove launcher power control box
 TM 5-5420-226-20

TA271825

GRENADE LAUNCHER POWER CONTROL BOX REPAIR (Sheet 2 of 7)

TESTING:

1. Lift switch guard (A) and push switch (B) to UP position.
2. Using multimeter, check for continuity reading of less than 2 ohms between connector (C) pins A and B.
3. Using multimeter, check for continuity reading of less than 2 ohms between connector (C) pins B and D.
4. If continuity readings are greater than 2 ohms in steps 2 and 3, remove cover. Do continuity checks on switch (B) and connector (C). Replace bad parts.
5. Set switch (B) to OFF by closing switch guard (A).
6. Using multimeter, check for continuity reading of greater than 10 million ohms between connector (C) pins A and B.
7. If reading is not greater than 10 million ohms in step 6, remove cover. Do continuity check on switch (B). Replace switch if bad.

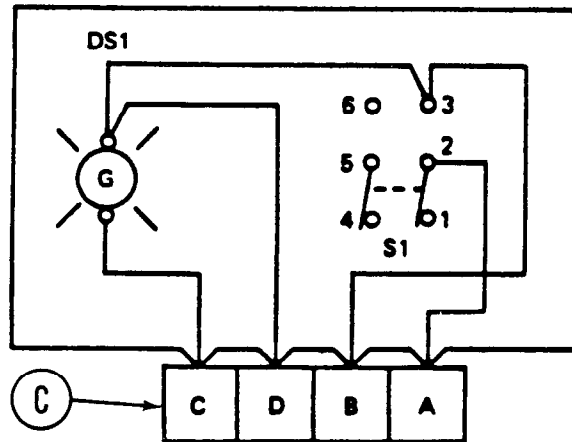
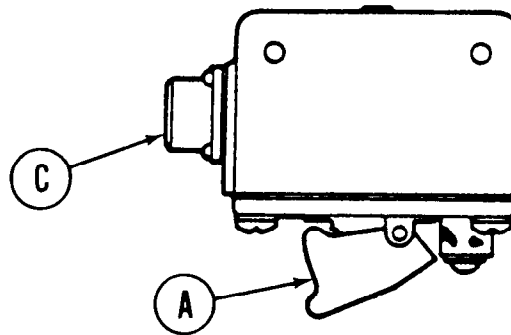
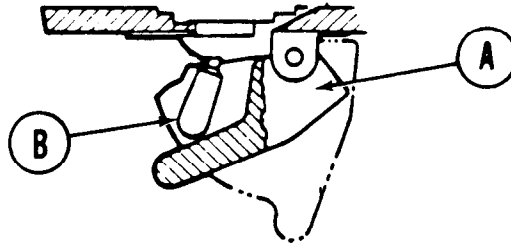

TA271826

GRENADE LAUNCHER POWER CONTROL BOX REPAIR (Sheet 3 of 7)

8. Connect positive lead of power source to connector (C) pin A.
9. Connect negative lead of power source to connector (C) pin C.
10. Lift switch guard (A) and set switch (B) to UP position.
11. If lamp (D) does not light, check continuity of switch (B), lamp housing (E), and connector (C). Replace bad parts.
12. Set switch (B) to OFF by closing switch guard (A).
13. If lamp (D) does not go out, check continuity of switch (B). Replace switch if bad.
14. Disconnect power source leads.

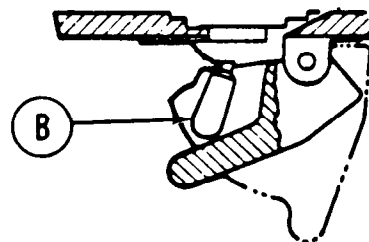
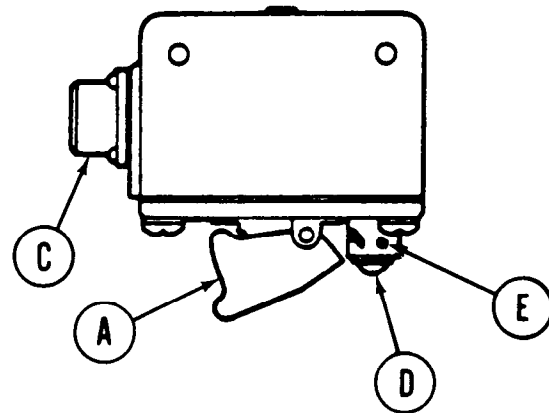
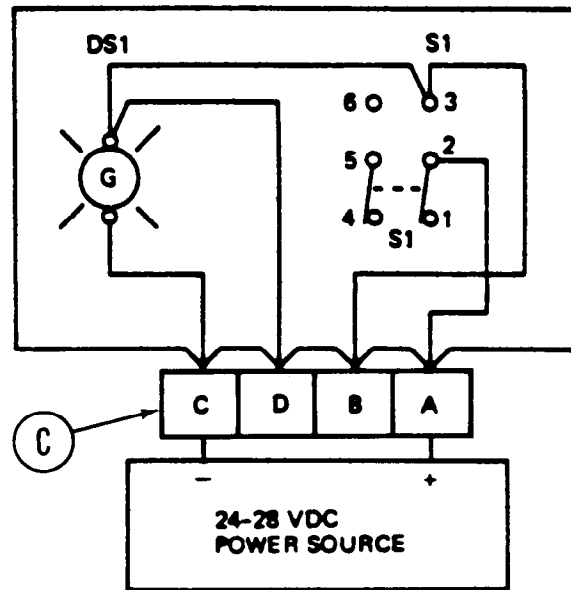

TA271827

GRENADE LAUNCHER POWER CONTROL BOX REPAIR (Sheet 4 of 7)

DISASSEMBLY:

1. Using screwdriver, remove four screws (A) and four lockwashers (B) that hold cover (C) to case (D).
2. Lift cover (C) with wires (E) attached, so you can get to parts inside case (D).
3. Remove gasket (F) by sliding over cover (C). Discard gasket.

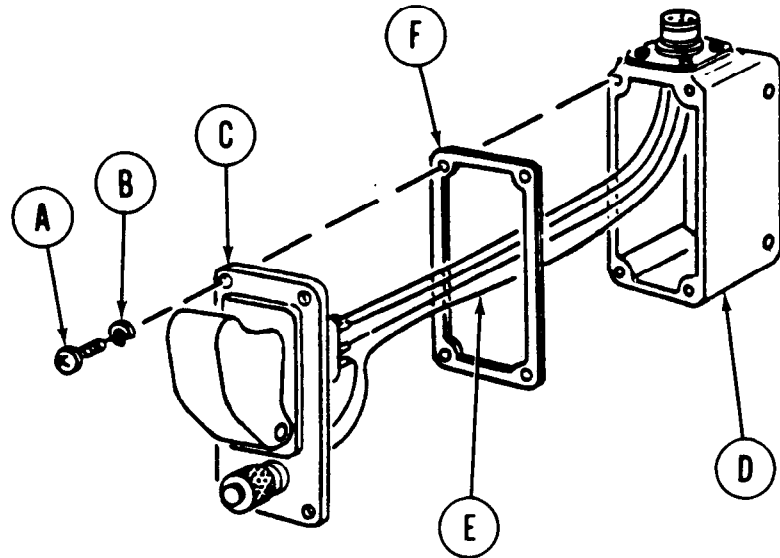

4. Using knife, remove insulation sleeving from four terminals of switch (G).
5. Using masking tape (Item 24, Appendix B), tag and mark each wire (H) connected to terminals of switch (G).
6. Using soldering iron, unsolder electrical wires (H) from terminals of switch (G).
7. Using wrench, remove nut (J), lockwasher (K), and switch guard (L) from switch (G).
8. Remove switch (G) from cover (C).
9. Remove packing (M), key washer (N), and flat washer (P) from switch (G). Discard packing.

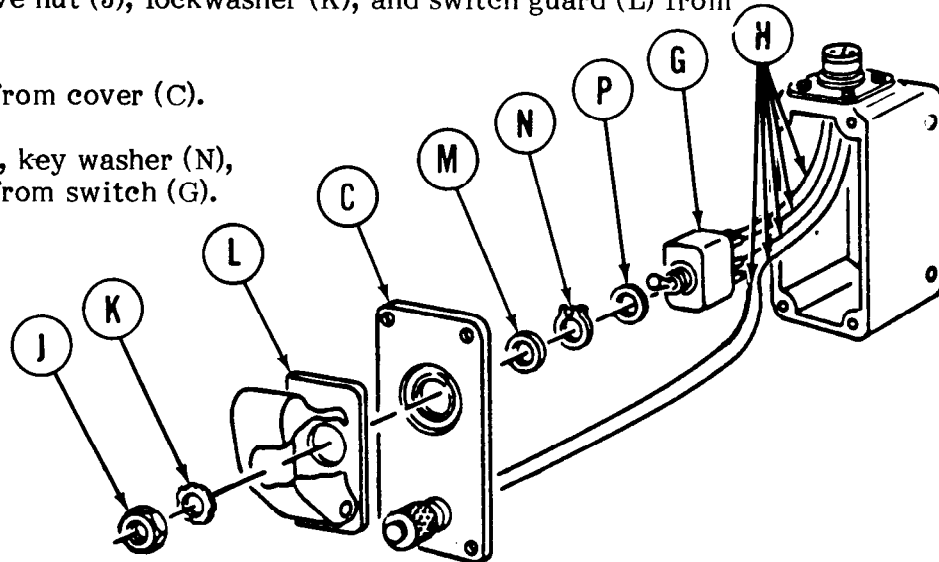

TA271828

GRENADA LAUNCHER POWER CONTROL BOX REPAIR (Sheet 5 of 7)

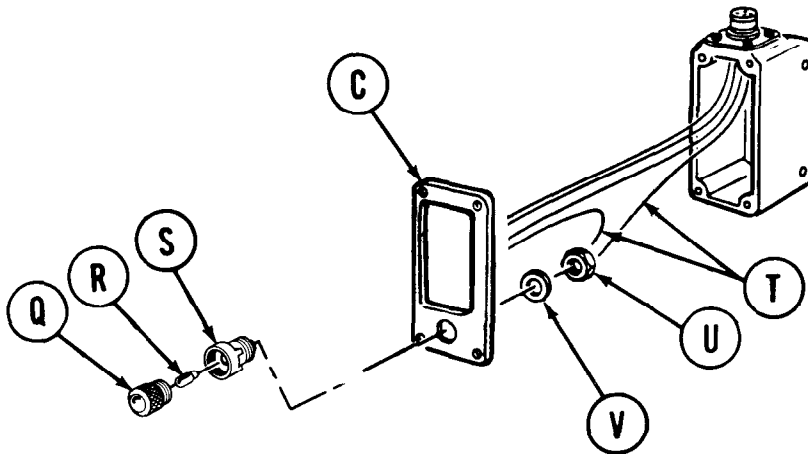

10. Remove lens (Q) and lamp (R) from light housing (S).
11. Using knife, remove insulation sleeving from two terminals on light housing (S).
12. Using masking tape (Item 24, Appendix B), tag and mark wires (T).
13. Using soldering iron, unsolder two wires (T) from terminals on light housing (S).
14. Using wrench, remove nut (U) and lockwasher (V) holding light housing (S) to cover (C).

15. Remove light housing (S) from cover (C).
16. Using screwdriver, remove four screws (W) and four lockwashers (X) that hold electrical connector (Y) to case (D).
17. Pull connector (Y) with wiring attached from case (D) so you can get to the wiring (Z).

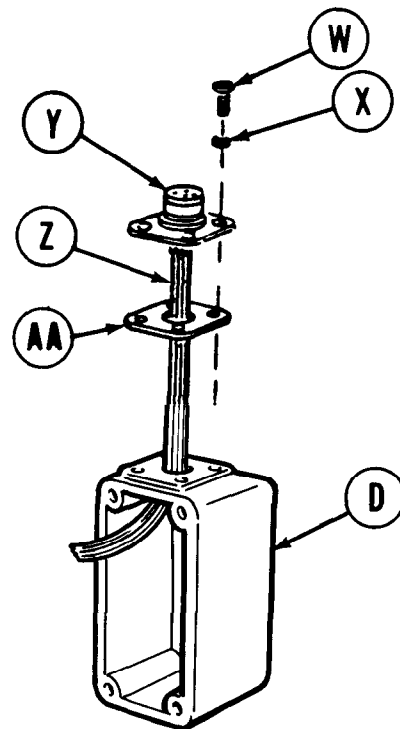

18. Using knife, remove insulation sleeving from four pins of connector (Y).
19. Using masking tape (Item 24, Appendix B), tag and mark each wire (Z).
20. Using soldering iron, unsolder four wires (Z) from pins of connector (Y).
21. Remove connector (Y) and gasket (AA) from case (D).

TA271829

GRENADE LAUNCHER POWER CONTROL BOX REPAIR (Sheet 6 of 7)

ASSEMBLY:

1. Using soldering iron and solder (Item 23.1, Appendix B), solder four wires (A) to proper pins on connector (B).
2. Remove tags from four wires (A).
3. Put 1/2" long piece of insulation sleeving (Item 15.1, Appendix B) on four wires (A).
4. Put insulation sleeving (Item 15.1, Appendix B) over pins of connector (B).
5. Using heat gun, shrink insulation sleeving.
6. Put four wires (A) through gasket (C) and case (D).
7. Put gasket (C) and connector (B) on case (D) and align holes.
8. Using screwdriver, attach connector (B) to case (D) with four lockwashers (E) and four screws (F).

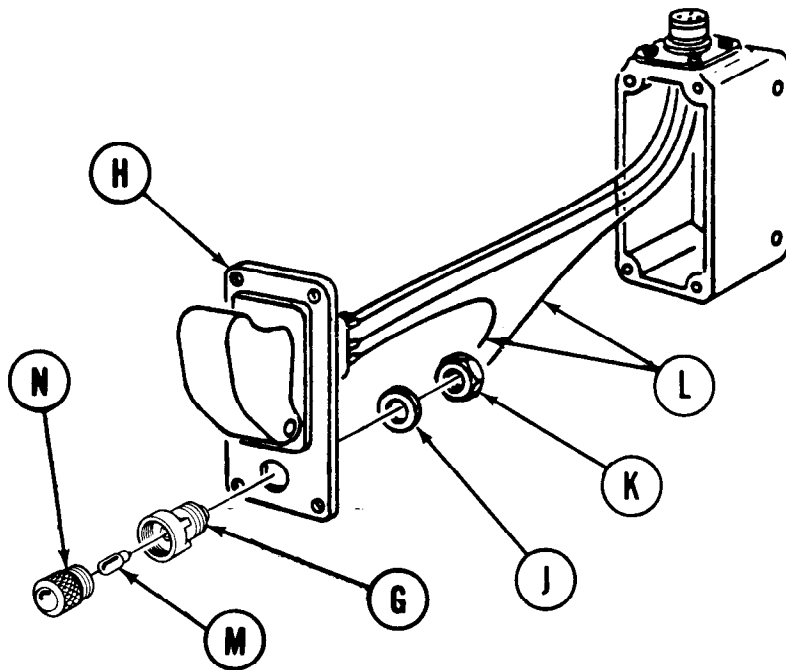
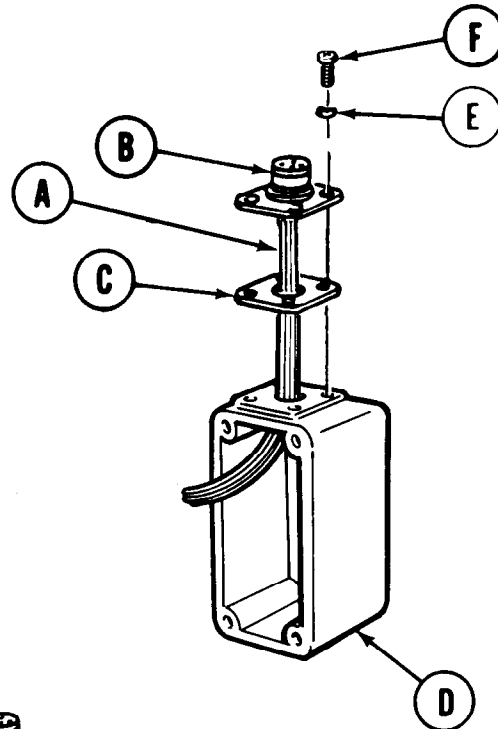

9. Using wrench, attach light housing (G) to cover (H) with lockwasher (J) and nut (K).
10. Put 1/2" long piece of insulation sleeving (Item 15.1, Appendix B) over two wires (L).
11. Using soldering iron and solder (Item 23.1, Appendix B), solder tagged wires (L) to terminals of light housing (G).
12. Remove tags from wires (L).
13. Put insulation sleeving over soldered terminals of light housing (G).
14. Using heat gun, shrink insulation sleeving.
15. Install lamp (M) and lens (N) onto light housing (G).

TA271830

GRENADE LAUNCHER POWER CONTROL BOX REPAIR (Sheet 7 of 7)

16. Put flat washer (P) on switch (Q).
17. Put key washer (R) on switch (Q) with key tab facing out.
18. Put packing (S) on switch (Q).

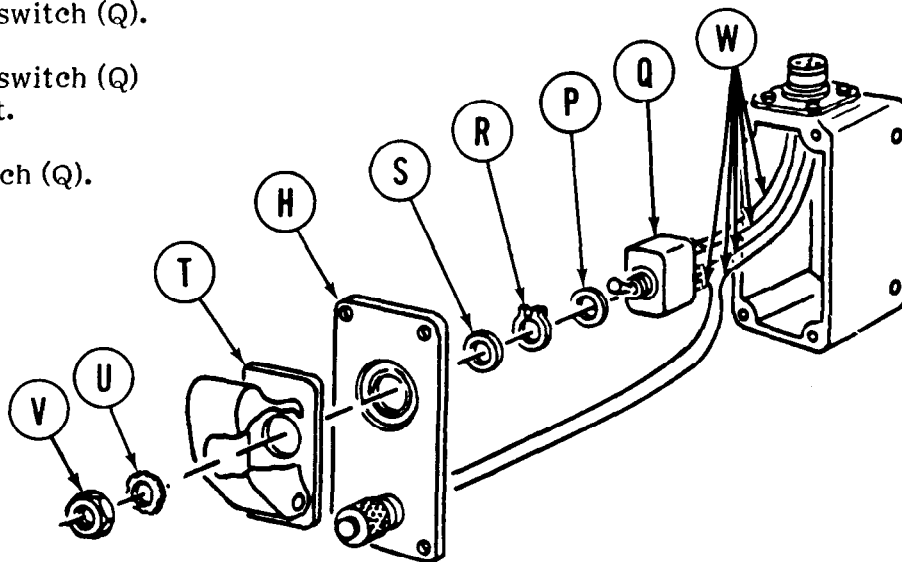

19. Place switch (Q) through hole in cover (H) with key tab aligned with keyway of cover.
20. Put switch guard (T) and lockwasher (U) on switch (Q).
21. Using wrench, put nut (V) on switch (Q) and tighten nut (V).
22. Put 1/2" long piece of insulation sleeving (Item 15.1, Appendix B) over each wire (W).
23. Using soldering iron and solder (Item 23.1, Appendix B), solder tagged wires (W) to terminals of switch (Q). Remove tags from wires.
24. Put insulation sleeving over soldered connections of switch (Q).
25. Using heat gun, shrink insulation sleeving.

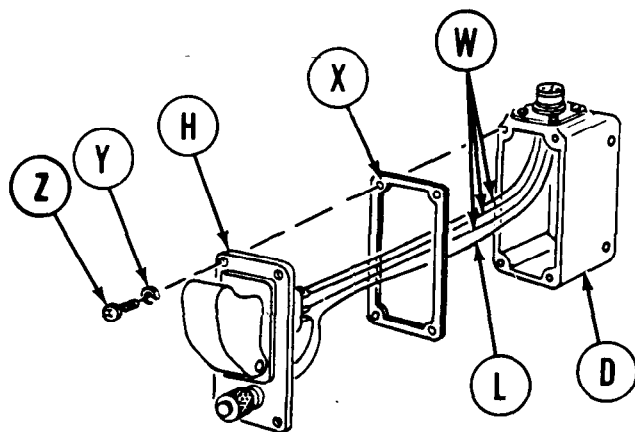

26. Slide new gasket (X) over cover (H).
27. Carefully place gasket (X) and cover (H) on case (D) while pushing wires (L) and (W) inside case (D).
28. Using screwdriver, attach cover (H) to case (D) with four lockwashers (Y) and four screws (Z).

End of Task

TA271831



CHAPTER 11
FIRE FIGHTING SYSTEM MAINTENANCE
INDEX

Procedure	Page
Fixed Fire Extinguisher Cylinder Servicing	11-2

FIXED FIRE EXTINGUISHER CYLINDER SERVICING (Sheet 1 of 1)

TOOLS: Beam scale

REFERENCE: TM 5-5420-226-20

PRELIMINARY PROCEDURE: Remove fixed fire extinguisher cylinders (TM 5-5420-226-20)

WARNING

- Handle charged cylinders with extreme caution. Do not jar or subject cylinders to temperatures above 140°F (60°C) to prevent accidental discharge.
- Do not handle fire extinguisher cylinders unless safety caps (A) are installed. Cylinders without safety caps installed, that are accidentally discharged, can cause injury to personnel and/or damage to equipment.

INSPECTION:

1. Inspect neck of bottle for pressure test data.
2. If cylinder is full, pressure test data must not be over 12 years old.
3. If cylinder is to be refilled, pressure test data must not be over 5 years old.
4. Inspect for plastic coating on indicator (B) over safety valve outlet. If indicator (B) is missing, cylinder is unserviceable.
5. Remove safety caps (A). Inspect threads of flood valve (C) and discharge port (D). Repair threads if required.
6. Install safety caps (A).
7. Using beam scales, weigh cylinder.
8. Serviceable cylinder must weigh a least 9 pounds more than empty weight. Empty weight is stamped on flood valve (C).
9. If cylinder does not pass inspection steps 2, 3, 4, 5, and 8, cylinder must be sent through supply channels for recharging or replacement.

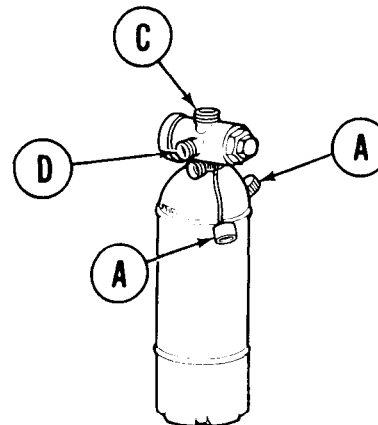
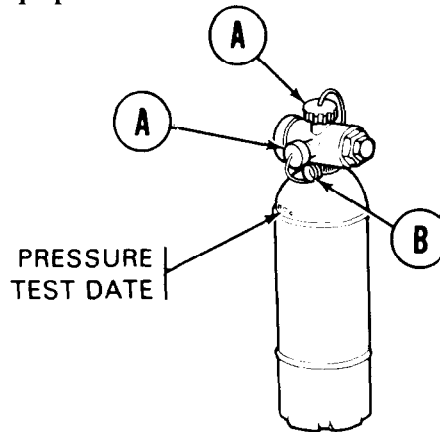

End of Task

CHAPTER 12

PRE-EMBARKATION INSPECTION

Refer to TM 55-2350-215-10-15, Transportability Guidance; Tank, Combat, Full-Track, M60 Series.

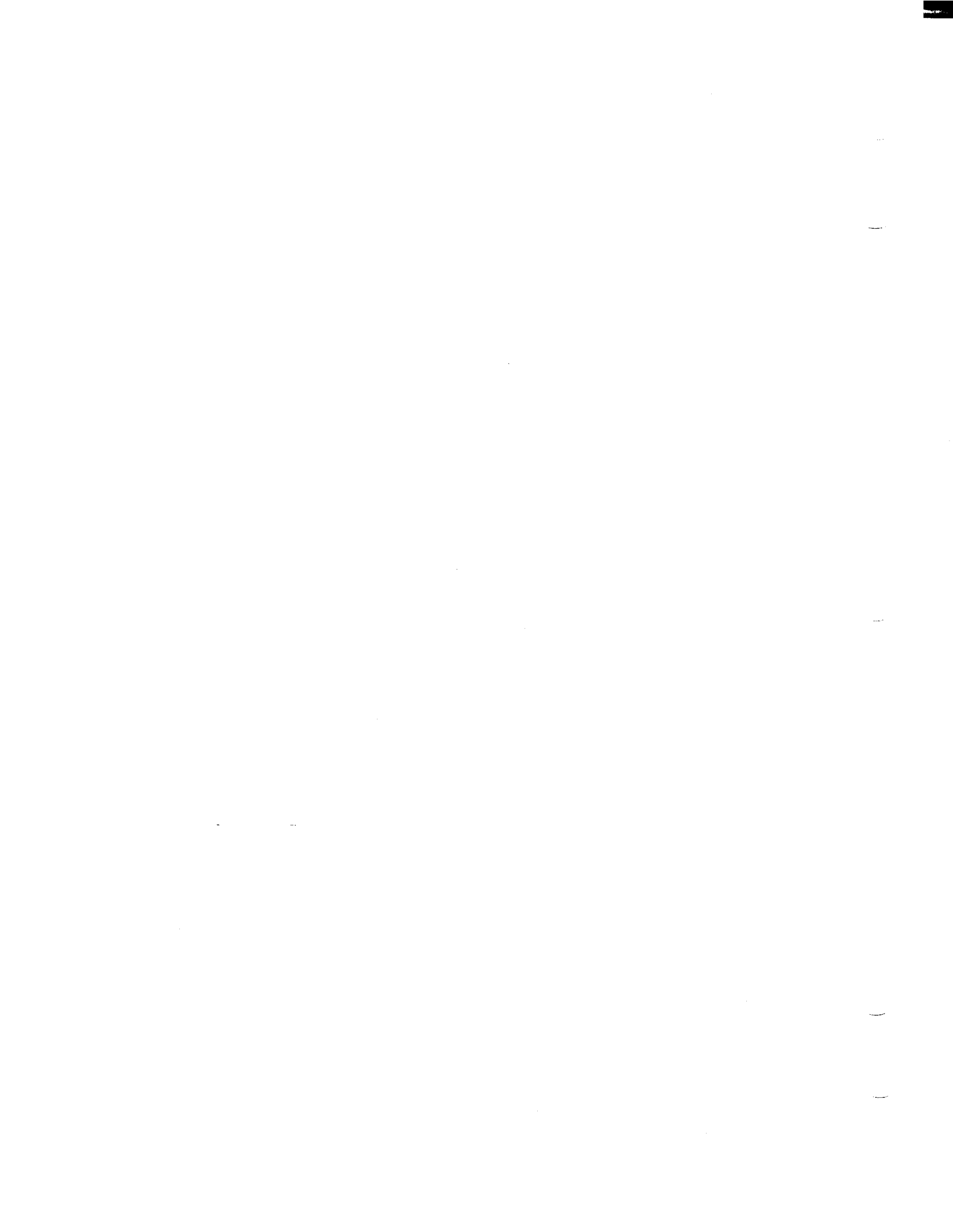

APPENDIX A Continued

A-7 Vehicle Manuals

- TM 5-5420-226-10 Operator's Manual for Launcher and Chassis, Tank, Transporting for M48A5 AVLB, Armored, Vehicle, Launcher, Bridge
- TM 5-5420-226-20 Organizational Maintenance Manual for Chassis, Tank, Transporting for M48A5 AVLB, Armored, Vehicle, Launcher, Bridge
- TM 5-5420-226-24P Unit, Direct Support, and General Support Maintenance Repair Parts and Special Tools List (Including Depot Maintenance Repair Parts) for Launcher and M48A5 Tank Chassis; Transporting: for Bridge, Armored-Vehicle-Launched, Scissoring Type, Class 60 (NSN 5420-01-076-6096)
- TM 5-5420-200-10-1 Transportability Guidance: Launcher M48 and M48A2: Tank Chassis, Transporting, and Bridge, 63-Foot, Scissoring Type, Class 60

A-8 Power Plant

- TM 9-2520-223-34 Direct Support and General Support Maintenance Manual (Including Repair Parts and Special Tools List) for Transmission, Model CD-850-6A
- TM 9-2815-220-34 Direct Support and General Support Maintenance for Engine, AVLB AVDS-1790-2D (NSN 2815-00-410-1204)
- TM 9-2815-220-34P Direct Support and General Support Maintenance Repair Parts and Special Tools List (Including Depot Maintenance Repair Parts and Special Tools) for Engine, AVLB AVDS-1790-2D
- TM 9-2910-212-34 Direct Support and General Support Maintenance Manual for Pump, Metering, Fuel Injection Assembly 10912447 (2910-00-064-6265) and 11684129 (2910-00-398-9550) (American Bosch Model PSB-12 BT)
- TM 9-2910-213-34 Direct Support and General Support Maintenance Manual (Including Direct Support and General Support Maintenance Repair Parts List): Pump, Fuel, Engine, Assembly 8725131, 8725282, 8275283, 10882763, and 10882763-1 (Viking Model FV492)
- TM 9-2920-224-35 DS and GS Maintenance Manual with Repair Parts and Special Tools List for Generator Assembly (300 AMP)
- TM 9-2920-232-34 Direct Support and General Support Maintenance Manual (Including Repair Parts List) for Starter Engine (Delco-Remy-GMC Model 1109972)
- TM 9-2990-205-34&P DS and GS Maintenance Manual with Repair Parts and Special Tools List for Turbosupercharger Model 5HDR

APPENDIX A Continued**A-9 Gas Particulate System**

- TM 3-4240-236-30 DS, GS, and Depot Maintenance Repair Parts and Special Tools List for Filter Unit, Gas Particulate, Tank, Three Man, 12 CFM, M8A2 (NSN 4240-00-691-1505) and Filter Unit, Gas Particulate, Tank, Four Man, 12 CFM, M8A3 (NSN 4240-00-853-3201)
- TM 3-4240-280-23&P Organizational and DS and GS Maintenance Manual (Including Repair Parts and Special Tools List): Mask Chemical-Biological, Tank, M25/M25A1 and Accessories

A-10 Supply Catalogs

- SC 4910-95-CL-A31 Shop Equipment, Automotive Maintenance and Repair: Field Maintenance, Basic, Less Power (4910-00-754-0705) (Line Item T24660) and Shop Equipment, Automotive Maintenance and Repair: Field Maintenance, Basic, MAP only (4910-00-919-0076)
- SC 4940-95-CL-A21 Shop Set, Contact and Emergency Repair: Field Maintenance (4940-00-754-0737) (Line Item T26030 Formerly Line Item 440568) and Shop Set, Contact and Emergency Repair: Field Maintenance MAP only (4940-00-919-0111)



APPENDIX B

EXPENDABLE SUPPLIES AND MATERIALS LIST

Section I. INTRODUCTION

B-1. Scope

This appendix lists expendable supplies and materials you will need to operate and maintain the M48A5 AVLB vehicle chassis. These items are authorized to you by CTA 50-970, Expendable Items (Except Medical, Class V, Repair Parts, and Heraldic Items).

B-2. Explanation of Columns

a. Column 1 - Item Number. This number is assigned to the entry in the listing and is referenced in the narrative instructions to identify the material, e.g., Use cleaning compound (Item 5, Appendix B).

b. Column 2 - Level. This column identifies the lowest level of maintenance that requires the listed item.

- C - Operator or crew
- O - Organizational maintenance
- F - Direct support maintenance
- H - General support maintenance

c. Column 3 - National Stock Number. This is the National stock number assigned to the item; use it to request or requisition the item.

d. Column 4 - Description. Indicates the Federal item name and, if required, a description to identify the item. The last line for each item indicates the part number followed by the Federal Supply Code for Manufacturer (FSCM) in parentheses, if applicable.

e. Column 5 - Unit of Measure (U/M). Indicates the measure used in performing the actual maintenance function. This measure is expressed by a two-character alphabetical abbreviation (e.g., ea, in, pr). If the unit of measure differs from the unit of issue, requisition the lowest unit of issue that will satisfy your requirements.

Section II. EXPENDABLE SUPPLIES AND MATERIALS LIST

(1) Item Number	(2) Level	(3) National Stock Number	(4) Description	(5) U/M
1	O	8040-00-664-4318	Adhesive, synthetic rubber (MMM-A-1617, Type II)	PT
2	O	1015-00-615-7206	Brush, channel	EA
3	C	5350-00-221-0872	Cloth, crocus (P-C-458)	SA
4	C	8305-00-286-5451	Cloth, emery (P-C-451)	SH
5	F	6850-00-256-0157	Compound, cleaning, high pressure (P-S-751)	GA
6	F	-	Compound, sealing (MIL-S-22473, Grade E)	OZ
7	O	8030-00-081-7818	Compound, sealing (MIL-S-22473, Grade CV)	OZ

Section II. EXPENDABLE SUPPLIES AND MATERIALS LIST (Continued)

(1) Item Number	(2) Level	(3) National Stock Number	(4) Description	(5) U/M
8	O	8030-00-081-2337	Compound, sealing (MIL-S-22473, Grade AV)	QT
9	O	8030-00-081-2325	Compound, sealing (MIL-S-22473, Grade HV)	QT
10	C	6850-00-880-7616	Compound, silicone (MIL-S-8660)	OZ
11	C	-	Detergent, liquid (P-S-598)	DR
12	C	6850-00-281-1985	Dry Cleaning Solvent (P-D-680)	GA
13	F	-	Dye, penetrating (MIL-I-25135)	-
14	C	9150-00-935-1017	Grease, GAA, automotive and artillery (MIL-G-10924)	OZ
15	C	9150-01-059-2586	Brake Fluid, silicone, automotive (MIL-B-46176)	GA
15.1	F	5970-00-082-3942	Insulation Sleeving (MIL-I-23053/5)	FT
16	C	-	Oil, diesel fuel (DF-1, DF-2)	-
17	C	9150-01-152-4117	Lubricating Oil, engine and transmission OE/HDO-15W/40 (MIL-L-2104)	QT
18	O	9150-00-233-4119	Oil, penetrating (VV-P-216)	QT
19	O	8030-01-041-1602	Paint, acid resistant (MIL-P-20689/22750)	QT
20	O	-	Paint, white enamel (TT-E-489)	QT
21	F	8030-00-963-0930	Primer, sealing (MIL-S-22473, Grade T)	QT
22	O	-	Primer, zinc chromate (TT-P-1757)	QT
23	F	-	Sandpaper, number 4/0	SH
23.1	F	3439-00-003-8601	Solder, SN60 (QQS-571)	CN
24	C	-	Tape, masking, 2-inch (UU-T-106)	RL
25	O	9525-00-277-4268	Wire, nickel, copper alloy (QQ-W-281)	RL
26	O	9505-00-191-3680	Wire, steel, carbon (QQ-W-461)	RL
27	O	9505-00-248-9849	Wire, steel, carbon (MS-20995-F41)	RL
28	C	7510-00-189-7881	Pencil, writing (SS-P-1605)	EA
29	O	8030-00-889-3534	Tape, antiseizing (pipe thread) (MIL-T-27730)	FT
30	O	8135-00-292-2342	Tag, Type A, Grade 3 (UU-T-81)	BX
31	O	8415-00-641-4601	Gloves, rubber	PR
32	O	4240-00-816-3819	Goggles, industrial	PR
33	C	6230-00-264-8261	Flashlight (MS991/V)	EA
34	O	2030-01-131-9189	Compound, sealing (MIL-S-46163, Type I, Grade K)	PT
35	C	7920-00-205-1711	Rag, wiping, cotton, white, 50-pound bale (DDD-R-30)	LB
36	F	8030-00-985-2350	Compound, sealing (MIL-S-7916)	TU
37	O	8040-00-877-9872	Adhesive (MIL-A-46106, Type I)	OZ
38	O	9150-00-223-4004	Grease (MIL-G-21164)	LB

APPENDIX C

ELECTRICAL SCHEMATICS

Refer to FO-1 and FO-2 in the back of this manual for the hull electrical system schematic diagrams.



APPENDIX D

ILLUSTRATED LIST OF MANUFACTURED ITEMS

MATERIAL SIZE		
STOCK SIZE	DESCRIPTION	WELDING REQUIREMENT
5/8 x 5/16 x 19 1/2	CARBON OR ALLOY STEEL	WELD IN ACCORDANCE WITH MIL-STD-1261 CLASS 3

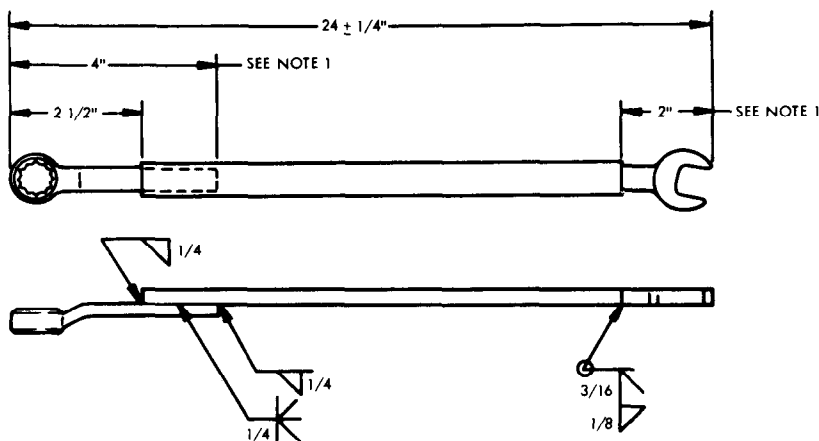

- NOTES:
1. USE 5/8" WRENCH NSN 5120-00-228-9508 CUT TO PROVIDE 2 PIECES SHOWN.
 2. TOLERANCE: $\pm 1/8"$
 3. ALL DIMENSIONS ARE IN INCHES.

Figure D-1. Double-ended wrench.

TA108572

MATERIAL SIZE	
STOCK SIZE	DESCRIPTION
7 1/8 X 1 1/4	DRILL ROD

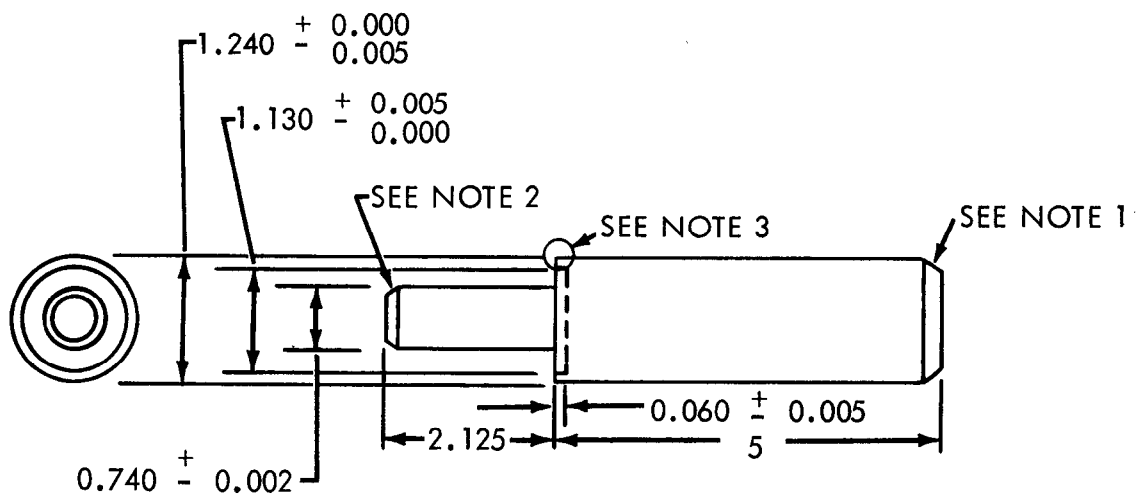

NOTES

1. CHAMFER AS NEEDED TO PREVENT MUSHROOMING
2. CHAMFER AS NEEDED FOR EASY ENTRY INTO BEARING
3. FLAME HARDEN
4. ALL DIMENSIONS ARE IN INCHES

Figure D-2. Bearing installation and removal tool.

TA108573

MATERIAL		
STOCK	DESCRIPTION	FABRICATING REQUIREMENT
1/8 in. Aluminum (QQ-S-698)	5 in. diameter	<ol style="list-style-type: none"> 1. Cut out aluminum plate and lay out holes. 2. Use a 5/16 inch drill, bore six holes through plate, 60 degrees apart, as shown.

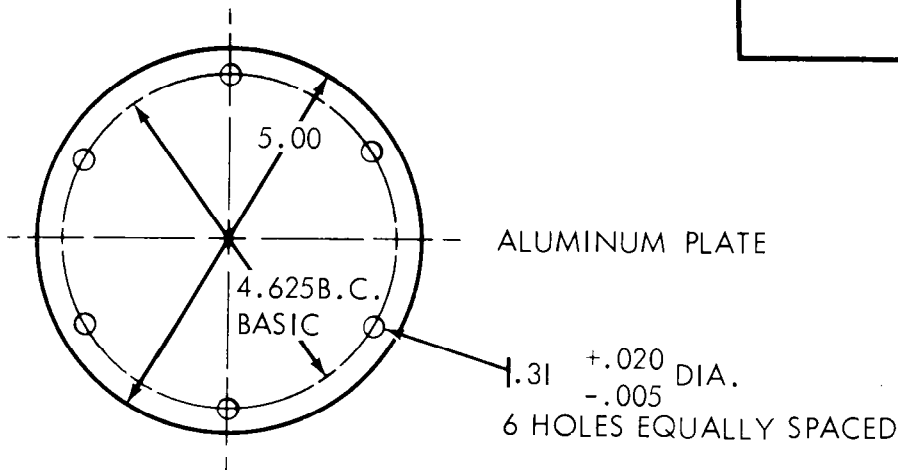

MATERIAL		
STOCK	DESCRIPTION	FABRICATING REQUIREMENT
1/16 Rubber Sheet	Goodyear Style 121 or equivalent	Punch six 5/16 in. holes, 60 degrees apart, as shown.

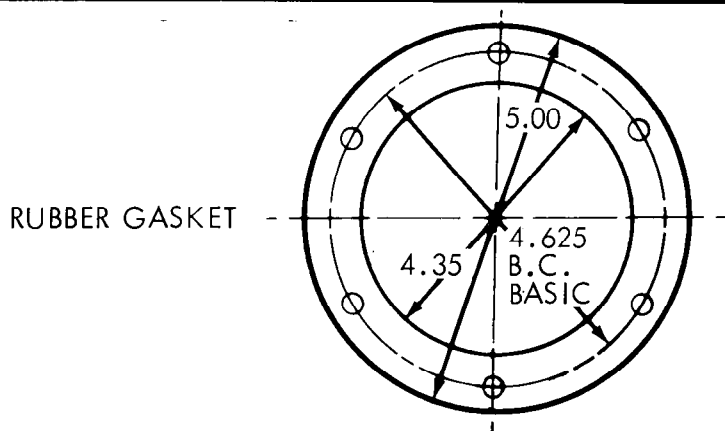

Figure D-3. Fuel tank crossover cover and gasket.

NOTE

Bearing installer is fabricated from spacers (8689162). Two installers are required for output shaft bearing installation.

Modify spacer (8689162) as follows:

- a. Using hand grinder, or other suitable tool, enlarge openings at each end of spacer enough to allow spacer to slip onto output shaft without binding.
- b. Remove all nicks and burrs.
- c. Mark modified spacer "UNSERVICABLE-PRESS ONLY."

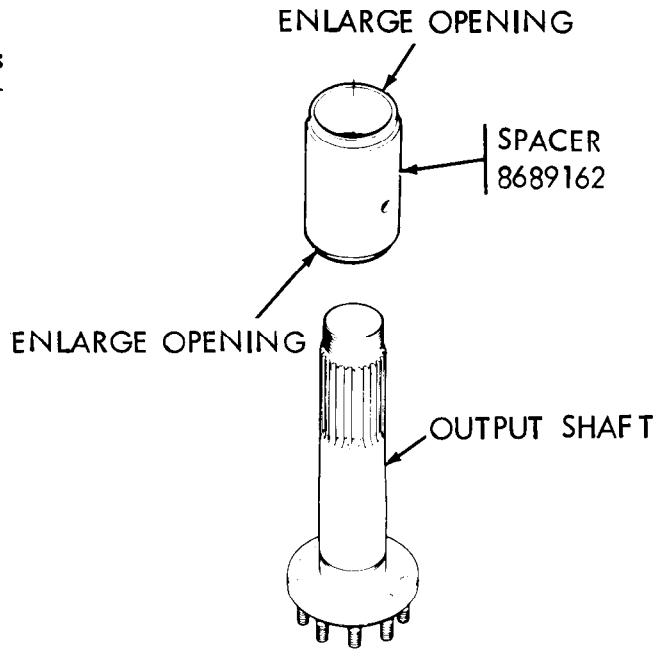

Figure D-4. Final drive output shaft and drive bearing installer.

NOTE

Two attachments are required.

1. Thread two nuts (NSN 5310-00-930-3447) on an unused stud or bolt to maintain thread alignment and weld together per TM 9-237.
2. Obtain eye (NSN 2520-00-840-4560). Cut off and throw away threaded portion.
3. Weld modified eye to welded nut assembly per TM 9-237.

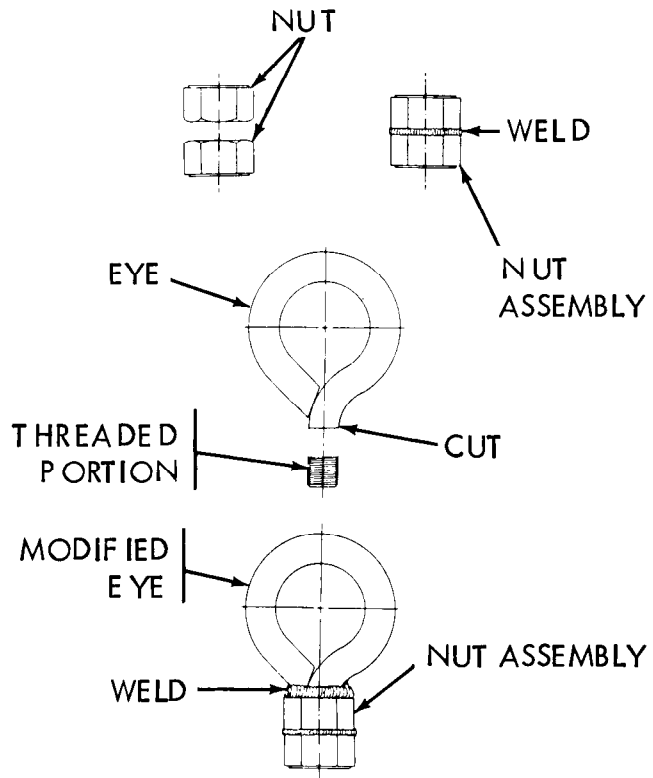

Figure D-5. Final drive lifting attachment.

ALPHABETICAL INDEX

Subject, Page

A

Accessory Drive Installation on
Unserviceable Engine, 3-46

Accessory Drive Removal from
Replacement Engine, 3-18

Accelerator Control Linkage Assembly
Repair
 Assembly, 4-94
 Cleaning, 4-91
 Disassembly, 4-86
 Inspection and Repair, 4-91

Accelerator Control Linkage Assembly
Replacement
 Cleaning and Inspection, 4-82
 Installation, 4-83
 Removal, 4-80

Air Cleaner Fan Repair
 Assembly, 4-6
 Cleaning and Inspection, 4-5
 Disassembly, 4-2
 Testing, 4-5

Subject, Page

B

Brake Master Cylinder Repair
 Assembly, 8-5
 Cleaning and Inspection, 8-4
 Disassembly, 8-2
 Repair, 8-4

Brake Slave Cylinder Repair
 Assembly, 8-10
 Cleaning and Inspection, 8-9
 Disassembly, 8-7
 Repair, 8-9

Bulkhead Cable Disconnect
 Installation, 5-3
 Removal, 5-2

Bulkhead-To-Brake Line Quick-Disconnect
 Hose Tube Assembly Replacement
 Installation, 8-18
 Removal, 8-17

C

Compensating Idler Arm
 Assembly, 9-27
 Disassembly, 9-24

ALPHABETICAL INDEX Continued

Subject, Page

E

Engine Replacement
 Accessory Drive Installation, 3-46
 Accessory Drive Removal, 3-18
 Power Takeoff Installation, 3-35
 Power Takeoff Removal, 3-25
 Replacement Engine Installation,
 3-61
 Unserviceable Engine Removal, 3-53

Expendable Supplies, B-1

F

Fabricated Tools, D-1

Final Drive Repair
 Assembly, 7-18
 Disassembly, 7-3
 Tests, Axial Play and Backlash, 7-29

Fixed Fire Extinguisher Cylinder
 Servicing, 11-2

Front Accessory Harness Replacement
 Installation, 5-90
 Removal, 5-83

Fuel Lines Replacement - Primer
 Pump (Inlet) (Outlet) from
 Bulkhead to Engine
 Installation, 4-78
 Removal, 4-76

Fuel Primer Pump Repair
 Assembly, 4-68
 Cleaning and Inspection, 4-67
 Disassembly, 4-64
 Test, 4-64

Subject, Page

F

Fuel Primer Pump Inlet Valve Assembly
 Repair
 Assembly, 4-73
 Cleaning and Inspection, 4-73
 Disassembly, 4-73

Fuel Primer Pump Outlet Valve Assembly
 Repair
 Assembly, 4-75
 Cleaning and Inspection, 4-74
 Disassembly, 4-74

ALPHABETICAL INDEX

Subject, Page

F

Fuel Tank Repair
 Cleaning and Inspection, 4-40
 Repair, 4-40
 Test, 4-41

H

How To Use This Manual, iii

Subject, Page

M

Maintenance Information Index, MI-1

Master Cylinder
 Assembly, 8-5
 Cleaning and Inspection, 8-4
 Disassembly, 8-2
 Repair, 8-4

Metric Conversion Chart, Inside Back
 Cover

P

Parking Brake Tube Assembly Replacement
 Installation, 8-15
 Removal, 8-13

Power/Master Control Panel Harness
 Replacement
 Installation, 5-79
 Removal, 5-75

Power Box, Grenade Launcher Control, Repair
 Assembly, 10.1-6
 Disassembly, 10.1-4
 Testing, 10.1-2

Power Takeoff Assembly Repair
 Assembly, 3-14
 Cleaning and Inspection, 3-14
 Disassembly, 3-10

Power Takeoff Installation on
 Replacement Engine, 3-35

ALPHABETICAL INDEX Continued

Subject, Page

P

- Power Takeoff Removal from Unserviceable Engine, 3-25
- Power Takeoff Replacement
 - Installation, 3-5
 - Removal, 3-2
- Primer Pump (Fuel) Repair
 - Assembly, 4-68
 - Cleaning and Inspection, 4-67
 - Disassembly, 4-65
 - Test, 4-64
- Primer Pump (Fuel) Inlet Valve Assembly Repair
 - Assembly, 4-73
 - Cleaning and Inspection, 4-73
 - Disassembly, 4-73
- Primer Pump (Fuel) Outlet Valve Assembly Repair
 - Assembly, 4-75
 - Cleaning and Inspection, 4-74
 - Disassembly, 4-74
- Primer Pump Piston Rod Assembly Repair (Fuel)
 - Assembly, 4-72
 - Cleaning and Inspection, 4-71
 - Disassembly, 4-70

R

- Rear Shifting Control Rod Replacement
 - Inspection, 6-17
 - Installation, 6-17
 - Removal, 6-16

Subject, Page

R

- Rear Shifting Linkage Shield Assembly Repair
 - Assembly, 6-12
 - Disassembly, 6-12
 - Inspection, 6-12
 - Installation, 6-13
 - Removal, 6-11
- Rear Steering Control Rod Replacement
 - Inspection, 10-17
 - Installation, 10-17
 - Removal, 10-16
- References, A-1
- Repair
 - Accelerator Control Linkage, 4-86
 - Air Cleaner Fan, 4-2
 - Brake Master Cylinder, 8-2
 - Brake Slave Cylinder, 8-7
 - Final Drive, 7-1
 - Primer Pump, 4-64
- Replacement
 - Accelerator Linkage, 4-80
 - Brake Line Quick-Disconnect, 8-17
 - Engine, 3-18
 - Transmission, 6-19
- Roadwheel Arm (Number 1), 9-6
 - Assembly, 9-9
 - Disassembly, 9-6
- Roadwheel Arm (Numbers 2 and 6), 9-12
 - Assembly, 9-15
 - Disassembly, 9-12
- Roadwheel Arm (Numbers 3, 4, and 5), 9-18
 - Assembly, 9-21
 - Disassembly, 9-18

ALPHABETICAL INDEX Continued

Subject, Page

S

Schematics, C-1

Shift Rod Locking Hasp Replacement
Installation, 6-18
Removal, 6-18

Service Upon Receipt, 2-3

Shifting Control Connecting Link Replacement and Repair
Installation, 6-3
Removal, 6-2

Shifting Control Rod Assembly Replacement
Inspection, 6-10
Installation, 6-10
Removal, 6-9

Shifting Control Shield Support Replacement
Installation, 6-15
Removal, 6-14

Shifting Control Sleeve Assembly Replacement and Repair
Assembly, 6-7
Disassembly, 6-6
Installation, 6-8
Removal, 6-5

Steering Control Mount Assembly Repair
Inspection and Repair, 10-2

Steering Control Rod Replacement
Inspection, 10-13
Installation, 10-13
Removal, 10-12

Subject, Page

S

Steering Control Sleeve Assembly Replacement and Repair
Assembly, 10-7
Disassembly, 10-6
Installation, 10-8
Removal, 10-5

Steering Handle Assembly Repair and Replacement
Installation, 10-4
Removal, 10-3

Steering Shaft Assembly Repair and Replacement
Installation, 10-10
Removal, 10-9

Support Steering Control Shield Replacement
Installation, 10-15
Removal, 10-14

T

Transmission Replacement
Cleaning, 6-29
Installation, 6-29
Removal, 6-19

ALPHABETICAL INDEX Continued

Subject, Page

W

Wiring Harnesses

- Bulkhead Cable Disconnect, 5-2
- Front Accessory, 5-83
- Power/Master Control Panel, 5-75

MAINTENANCE INFORMATION INDEX

	Disassemble	Clean	Inspect	Repair	Remove	Install	Assemble	Test
Accelerator Control Linkage	4-87	4-91	4-91	4-86	4-80	4-83	4-94	-
Air Cleaner Fan	4-2	4-5	4-5	4-2	-	-	4-6	4-5
Basket/Control Panel Accessory Harness	-	-	-	-	5-36	5-39	-	-
Basket/Control Panel Heater Harness	-	-	-	-	5-50	5-52	-	-
Basket/Control Panel Power Harness	-	-	-	-	5-27	5-29	-	-
Basket/Control Panel Starting Harness	-	-	-	-	5-31	5-34	-	-
Basket Wiring Harness Disconnect	-	-	-	-	5-71	5-73	-	-
Basket/Gage Indicator Panel Harness	-	-	-	-	5-59	5-62	-	-
Basket/Light Switch Harness	-	-	-	-	5-41	5-46	-	-
Brake Master Cylinder	8-2	8-4	8-4	8-4	-	-	8-5	-
Brake Slave Cylinder	8-7	8-9	8-9	8-9	-	-	8-10	-
Bulkhead Cable Disconnect	-	-	-	-	5-2	5-3	-	-
Bulkhead-To-Brake Line Quick-Disconnect	-	-	-	-	8-17	8-18	-	-
Compensating Idler Arm	9-24	-	-	-	-	9-27	-	-
Engine	-	-	-	-	3-18	3-18	-	-
Engine Disconnect Wiring Harness	-	-	-	-	5-9	5-12	-	-
Final Drive	7-3	-	-	-	-	-	7-18	7-29
Fixed Fire Extinguisher	-	-	11-2	-	-	-	-	-
Front Accessory Wiring Harness	-	-	-	-	5-83	5-90	-	-
Fuel Line Replacement Primer Pump	-	-	-	-	4-76	4-78	-	-
Fuel Primer Inlet Valve Assembly	4-73	4-73	4-73	-	-	-	4-73	-
Fuel Primer Outlet Valve Assembly	4-74	4-74	4-74	-	-	-	4-75	-
Fuel Primer Pump	4-65	4-67	4-67	4-64	-	-	4-68	4-64
Fuel Tank (L&R)	-	4-40	4-40	4-41	4-9(R)	4-17(R)	-	4-41
	-	-	-	-	4-24(L)	4-32(L)	-	-
Fuel Tank Lower Rear Mount (L&R)	-	4-44	4-44	-	4-42	4-44	-	-
Fuel Tank Upper Front Mount (L&R)	-	4-55	4-55	-	4-53	4-56	-	-
Fuel Tank Upper Rear Mount (L&R)	-	4-60	4-60	-	4-59	4-61	-	-
Heater/Basket Wiring Harness	-	-	-	-	5-54	5-57	-	-
Infrared Periscope Cable	-	-	-	-	5-65	5-68	-	-
Left Fuel Tank Lower Front Mount	-	4-48	4-48	-	4-46	4-48	-	-
Left Fuel Tank Lower Front Mounting Bracket	-	-	-	-	4-62	4-63	-	-
Parking Brake Tube Assembly	-	-	-	-	8-13	8-15	-	-
Power/Master Control Panel Wiring Harness	-	-	-	-	5-75	5-79	-	-

MAINTENANCE INFORMATION INDEX - Continued

	Disassemble	Clean	Inspect	Repair	Remove	Install	Assemble	Test
Power Box, Grenade Launcher Control	10.1-4	-	-	10.1-1	-	-	10.1-6	10.1-2
Power Relay Cable Assembly	-	-	-	-	5-15	5-17	-	-
Power Takeoff	-	-	-	-	3-2	3-5	-	-
Rear Accessory Wiring Harness	-	-	-	-	5-20	5-24	-	-
Rear Shifting Control Rod	-	-	6-17	-	6-16	6-17	-	-
Rear Shifting Linkage Shield	6-12	-	6-12	-	6-11	6-13	6-12	-
Right Fuel Tank Lower Front Mount Replacement	-	4-52	4-52	-	4-50	4-52	-	-
Roadwheel Arm No. 1 (L&R)	9-6	-	-	-	-	-	9-9	-
Roadwheel Arm No. 2 and No. 6	9-12	-	-	-	-	-	9-15	-
Roadwheel Arm No. 3, 4, and 5	9-18	-	-	-	-	-	9-21	-
Shifting Control Connecting Link	-	-	-	6-2	6-2	6-3	-	-
Shifting Control Rod	-	-	6-10	-	6-9	6-10	-	-
Shifting Control Sleeve	6-6	-	-	6-5	6-5	6-8	6-7	-
Shifting Control Shield Support	-	-	-	-	6-14	6-15	-	-
Starter Feed Wiring Harness	-	-	-	-	5-4	-	-	-
Steering Control Mount	-	-	10-2	10-2	-	-	-	-
Steering Control Rod	-	-	10-13	-	10-12	10-13	-	-
Steering Control Shield	-	10-21	10-21	-	10-14	10-15	-	-
Steering Control Sleeve	10-6	-	-	10-5	10-5	10-8	10-7	-
Steering Handle Assembly	-	-	-	-	10-3	10-4	-	-
Steering Shaft Assembly	-	-	-	-	10-9	10-10	-	-
Support Steering Control Shield	-	-	-	-	10-14	10-15	-	-
Transmission	-	6-29	-	-	6-19	6-29	-	-

By Order of the Secretary of the Army:

E. C. MEYER
General, United States Army
Chief of Staff

Official:

J. C. PENNINGTON
Major General, United States Army
The Adjutant General

To be distributed in accordance with DA Form 12-37, Direct and General Support
Maintenance requirements for Tank, Bridge Launcher, AVLB.



RECOMMENDED CHANGES TO PUBLICATIONS AND BLANK FORMS						Use Part II (<i>reverse</i>) for Repair Parts and Special Tool Lists (RPSTL) and Supply Catalogs/Supply Manuals (SC/SM).	DATE
For use of this form, see AR 25-30; the proponent agency is ODISC4.							
TO: (<i>Forward to proponent of publication or form</i>) (<i>Include ZIP Code</i>) AMSTA-LC-LPIT / TECH PUBS, TACOM-RI 1 Rock Island Arsenal Rock Island, IL 61299-7630						FROM: (<i>Activity and location</i>) (<i>Include ZIP Code</i>)	
PART I - ALL PUBLICATIONS (EXCEPT RPSTL AND SC/SM) AND BLANK FORMS							
PUBLICATION/FORM NUMBER TM 5-5420-226-34						DATE 27 February 1981	TITLE M48A5 Tank Chassis, Transporting: for Bridge, Armored-Vehicle Launched, Scissoring Type, Class 60
ITEM NO.	PAGE NO.	PARA-GRAPH	LINE NO. *	FIGURE NO.	TABLE NO.	RECOMMENDED CHANGES AND REASON (<i>Provide exact wording of recommended changes, if possible.</i>)	
<i>*Reference to line numbers within the paragraph or subparagraph.</i>							
TYPED NAME, GRADE OR TITLE				TELEPHONE EXCHANGE/AUTOVON, PLUS EXTENSION		SIGNATURE	

TO: <i>(Forward direct to addressee listed in publication)</i> AMSTA-LC-LPIT / TECH PUBS, TACOM-RI 1 Rock Island Arsenal Rock Island, IL 61299-7630	FROM: <i>(Activity and location) (Include ZIP Code)</i>	DATE
--	---	------

PART II - REPAIR PARTS AND SPECIAL TOOL LISTS AND SUPPLY CATALOGS/SUPPLY MANUALS

PUBLICATION NUMBER TM 5-5420-226-34	DATE 27 February 1981	TITLE M48A5 Tank Chassis, Transporting: for Bridge, Armored-Vehicle Launched, Scissoring Type, Class 60
--	--------------------------	---

PAGE NO.	COLM NO.	LINE NO.	NATIONAL STOCK NUMBER	REFERENCE NO.	FIGURE NO.	ITEM NO.	TOTAL NO. OF MAJOR ITEMS SUPPORTED	RECOMMENDED ACTION

PART III - REMARKS *(Any general remarks or recommendations, or suggestions for improvement of publications and blank forms. Additional blank sheets may be used if more space is needed.)*

TYPED NAME, GRADE OR TITLE	TELEPHONE EXCHANGE/AUTOVON, PLUS EXTENSION	SIGNATURE
----------------------------	--	-----------

RECOMMENDED CHANGES TO PUBLICATIONS AND BLANK FORMS For use of this form, see AR 25-30; the proponent agency is ODISC4.						Use Part II (<i>reverse</i>) for Repair Parts and Special Tool Lists (RPSTL) and Supply Catalogs/Supply Manuals (SC/SM).	DATE
TO: (<i>Forward to proponent of publication or form</i>) (<i>Include ZIP Code</i>) AMSTA-LC-LPIT / TECH PUBS, TACOM-RI 1 Rock Island Arsenal Rock Island, IL 61299-7630						FROM: (<i>Activity and location</i>) (<i>Include ZIP Code</i>)	
PART I - ALL PUBLICATIONS (EXCEPT RPSTL AND SC/SM) AND BLANK FORMS							
PUBLICATION/FORM NUMBER TM 5-5420-226-34						DATE 27 February 1981	TITLE M48A5 Tank Chassis, Transporting: for Bridge, Armored-Vehicle Launched, Scissoring Type, Class 60
ITEM NO.	PAGE NO.	PARA-GRAPH	LINE NO. *	FIGURE NO.	TABLE NO.	RECOMMENDED CHANGES AND REASON (<i>Provide exact wording of recommended changes, if possible.</i>)	
<i>*Reference to line numbers within the paragraph or subparagraph.</i>							
TYPED NAME, GRADE OR TITLE				TELEPHONE EXCHANGE/AUTOVON, PLUS EXTENSION		SIGNATURE	

TO: <i>(Forward direct to addressee listed in publication)</i> AMSTA-LC-LPIT / TECH PUBS, TACOM-RI 1 Rock Island Arsenal Rock Island, IL 61299-7630	FROM: <i>(Activity and location) (Include ZIP Code)</i>	DATE
--	---	------

PART II - REPAIR PARTS AND SPECIAL TOOL LISTS AND SUPPLY CATALOGS/SUPPLY MANUALS

PUBLICATION NUMBER TM 5-5420-226-34	DATE 27 February 1981	TITLE M48A5 Tank Chassis, Transporting: for Bridge, Armored-Vehicle Launched, Scissoring Type, Class 60
--	--------------------------	---

PAGE NO.	COLM NO.	LINE NO.	NATIONAL STOCK NUMBER	REFERENCE NO.	FIGURE NO.	ITEM NO.	TOTAL NO. OF MAJOR ITEMS SUPPORTED	RECOMMENDED ACTION

PART III - REMARKS *(Any general remarks or recommendations, or suggestions for improvement of publications and blank forms. Additional blank sheets may be used if more space is needed.)*

TYPED NAME, GRADE OR TITLE	TELEPHONE EXCHANGE/AUTOVON, PLUS EXTENSION	SIGNATURE
----------------------------	--	-----------

FO-1

HULL
ELECTRICAL
SYSTEM

SHEET 1 of 3



FO-1

HULL
ELECTRICAL
SYSTEM

SHEET 2 of 3



FO-1

HULL
ELECTRICAL
SYSTEM

SHEET 3 of 3



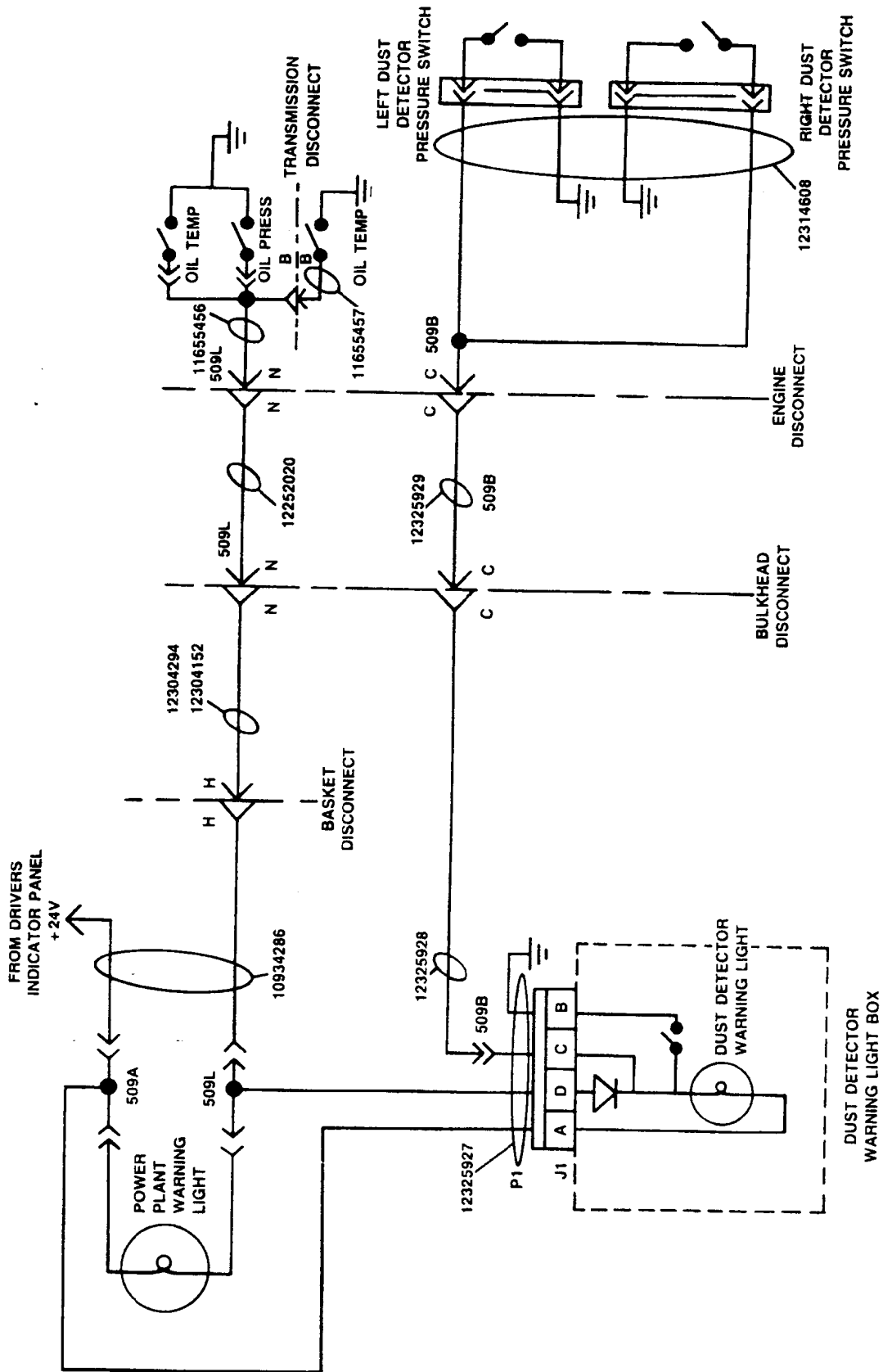

FO-2. Dust Detector Schematic Diagram For Vehicles Equipped With 2DA Engine.



THE METRIC SYSTEM AND EQUIVALENTS

LINEAR MEASURE

1 Centimeter = 10 Millimeters = 0.01 Meters = 0.3937 Inches
 1 Meter = 100 Centimeters = 1000 Millimeters = 39.37 Inches
 1 Kilometer = 1000 Meters = 0.621 Miles

WEIGHTS

1 Gram = 0.001 Kilograms = 1000 Milligrams = 0.035 Ounces
 1 Kilogram = 1000 Grams = 2.2 Lb.
 1 Metric Ton = 1000 Kilograms = 1 Megagram = 1.1 Short Tons

LIQUID MEASURE

1 Milliliter = 0.001 Liters = 0.0338 Fluid Ounces
 1 Liter = 1000 Milliliters = 33.82 Fluid Ounces

SQUARE MEASURE

1 Sq. Centimeter = 100 Sq. Millimeters = 0.155 Sq. Inches
 1 Sq. Meter = 10,000 Sq. Centimeters = 10.76 Sq. Feet
 1 Sq. Kilometer = 1,000,000 Sq. Meters = 0.386 Sq. Miles

CUBIC MEASURE

1 Cu. Centimeter = 1000 Cu. Millimeters = 0.06 Cu. Inches
 1 Cu. Meter = 1,000,000 Cu. Centimeters = 35.31 Cu. Feet

TEMPERATURE

$\frac{5}{9}(^{\circ}\text{F} - 32) = ^{\circ}\text{C}$
 212° Fahrenheit is equivalent to 100° Celsius
 90° Fahrenheit is equivalent to 32.2° Celsius
 32° Fahrenheit is equivalent to 0° Celsius
 $\frac{9}{5}^{\circ}\text{C} + 32 = ^{\circ}\text{F}$

APPROXIMATE CONVERSION FACTORS

TO CHANGE	TO	MULTIPLY BY
Inches	Centimeters	2.540
Feet	Meters	0.305
Yards	Meters	0.914
Miles	Kilometers	1.609
Square Inches	Square Centimeters	6.451
Square Feet	Square Meters	0.093
Square Yards	Square Meters	0.836
Square Miles	Square Kilometers	2.590
Acres	Square Hectometers	0.405
Cubic Feet	Cubic Meters	0.028
Cubic Yards	Cubic Meters	0.765
Fluid Ounces	Milliliters	29.573
Pints	Liters	0.473
Quarts	Liters	0.946
Gallons	Liters	3.785
Ounces	Grams	28.349
Pounds	Kilograms	0.454
Short Tons	Metric Tons	0.907
Pound-Feet	Newton-Meters	1.356
Pounds per Square Inch	Kilopascals	6.895
Miles per Gallon	Kilometers per Liter	0.425
Miles per Hour	Kilometers per Hour	1.609

TO CHANGE	TO	MULTIPLY BY
Centimeters	Inches	0.394
Meters	Feet	3.280
Meters	Yards	1.094
Kilometers	Miles	0.621
Square Centimeters	Square Inches	0.155
Square Meters	Square Feet	10.764
Square Meters	Square Yards	1.196
Square Kilometers	Square Miles	0.386
Square Hectometers	Acres	2.471
Cubic Meters	Cubic Feet	35.315
Cubic Meters	Cubic Yards	1.308
Milliliters	Fluid Ounces	0.034
Liters	Pints	2.113
Liters	Quarts	1.057
Liters	Gallons	0.264
Grams	Ounces	0.035
Kilograms	Pounds	2.205
Metric Tons	Short Tons	1.102
Newton-Meters	Pound-Feet	0.738
Kilopascals	Pounds per Square Inch	0.145
Kilometers per Liter	Miles per Gallon	2.354
Kilometers per Hour	Miles per Hour	0.621

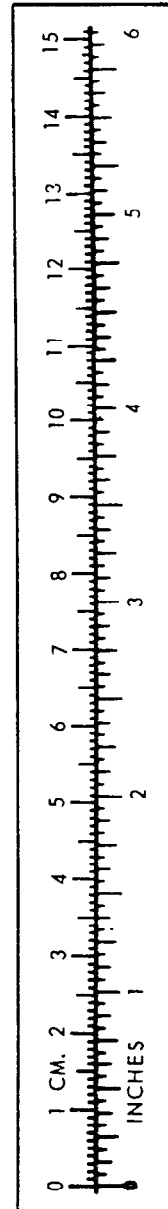

TA089991

PIN: 048120-000